

G631 SERIES TWO STAGE SERVOVALVES

G631 SERIES SERVOVALVES

The G631 Series flow control servovalves are throttle valves for 3- and preferably 4-way applications. They are a medium performance, two-stage design that covers the range of rated flows from 1.0 to 20 gpm at 1,000 psi valve drop. The output stage is a closed center, four-way sliding spool. The pilot stage is a symmetrical double-nozzle and flapper, driven by a double air gap, dry torque motor. Mechanical feedback of the spool position is provided

by a cantilever spring. The valve design is simple and rugged for dependable, long life operation.

These valves are suitable for electrohydraulic position, speed, pressure or force control systems with high dynamic response requirements.

Principle of operation

An electrical command signal (flow rate set point) is applied to the torque motor coils and creates a magnetic force which acts on the ends of the pilot stage armature. This causes a

deflection of armature/flapper assembly within the flexure tube. Deflection of the flapper restricts fluid flow through one nozzle which is carried through to one spool end, displacing the spool.

Movement of the spool opens the supply pressure port (P) to one control port, while simultaneously opening the tank port (T) to the other control port. The spool motion also applies a force to the cantilever spring, creating a restoring torque on the armature/flapper

assembly. Once the restoring torque becomes equal to the torque from the magnetic forces, the armature/flapper assembly moves back to the neutral position, and the spool is held open in a state of equilibrium until the command signal changes to a new level.

In summary, the spool position is proportional to the input current. With constant pressure drop across the valve, flow to the load is proportional to the spool position.

VALVE FEATURES

- > 2-stage design with dry torque motor
- > Low friction double nozzle pilot stage
- > High spool driving forces
- > ISO 4401 port pattern for 4-ports (external pilot supply is not per ISO 4401 location)
- > Rugged, long-life design
- > High resolution, low hysteresis
- > Completely set-up at the factory
- > Optional fifth port for separate pilot supply
- > Field replaceable first stage disc filter

The actual flow is dependent upon electrical command signal and valve pressure drop. The flow for a given valve pressure drop can be calculated using the square root function for sharp edge orifices:

$$Q = Q_N \sqrt{\frac{\Delta p}{\Delta p_N}}$$

Q gpm[l/min] = calculated flow

Q_N gpm[l/min] = rated flow

Δp psi[bar] = actual valve pressure drop

Δp_N psi[bar] = rated valve pressure drop



This catalog is for users with technical knowledge. To ensure that all necessary characteristics for function and safety of the system are given, the user has

to check the suitability of the products described here. In case of doubt, please contact Moog Inc.

G631 SERIES GENERAL TECHNICAL DATA

Operating Pressure

Main stage: ports P, X, A and B 3,000 psi [210 bar]
port T 2,000 psi [140 bar]

Temperature Range

Fluid -20° to 275°F [-29° to 135°C]
Ambient -20° to 275°F [-29° to 135°C]

Seal Material*

Viton

Operating Fluid

Compatible with common hydraulic fluids, other fluids on request.

Recommended viscosity 60 – 450 SUS @ 100°F

System Filtration: High pressure filter (without bypass, but with dirt alarm) mounted in the main flow and, if possible, directly upstream of the valve. Refer to Moog filtration catalog for recommended filtration scheme.

Class of Cleanliness: The cleanliness of the hydraulic fluid greatly effects the performance (spool positioning, high resolution) and wear (metering edges, pressure gain, leakage) of the servovalve.

Recommended Cleanliness Class

For normal operation ISO 4406 < 16/13
For longer life ISO 4406 < 15/12

Recommended Filter Rating

For normal operation $\beta_{10} \geq 75$ (15 μm absolute)
For longer life $\beta_5 \geq 75$ (10 μm absolute)

Installation Operations

Any position, fixed or movable.

Vibration

15 g, 3 axes

Weight

4.7 lbs [2.1 kg]

Degree of Protection

EN60529P: class IP65, with mating connector mounted.

Shipping Plate

Delivered with an oil sealed shipping plate.

* Other seal materials available upon request

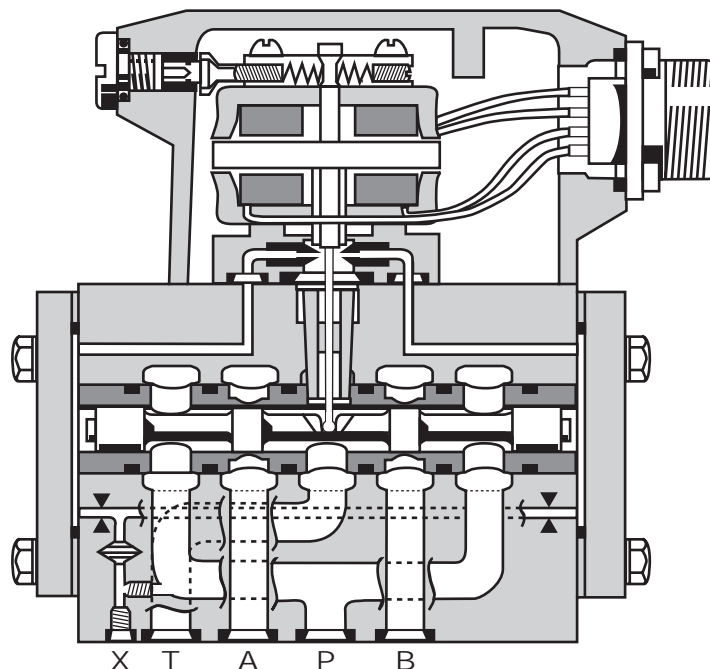
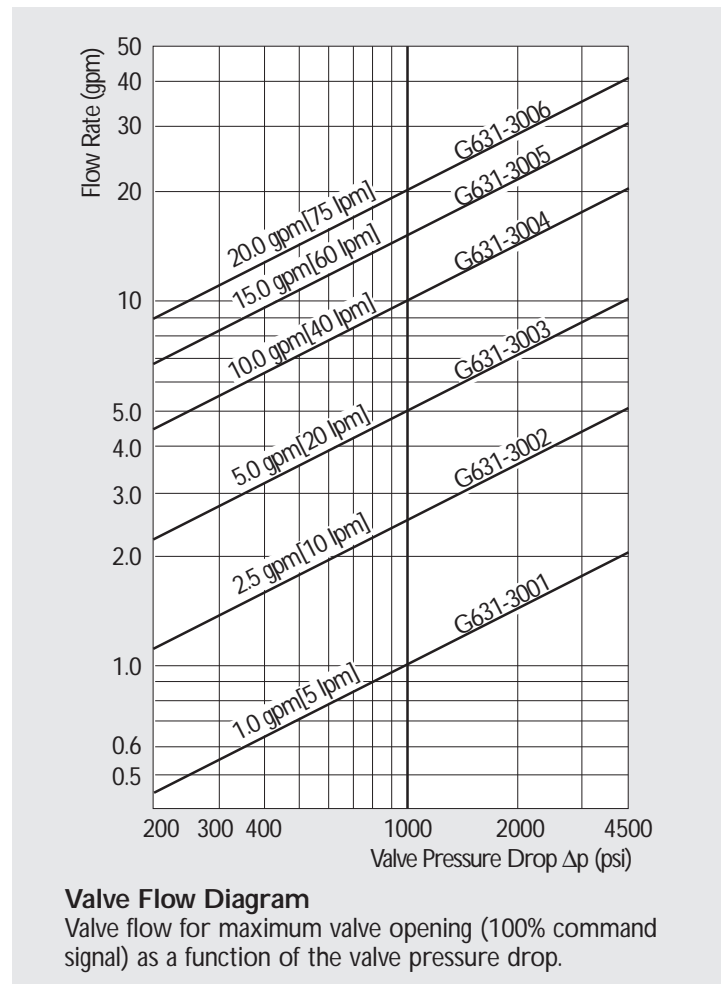

G631 SERIES
TECHNICAL DATA

Model... Type	G631-.....	
Mounting Pattern	ISO 4401-05-05-0-94 (for 4 ports)	
Valve Body Version	4-way 2-stage with spool-bushing assembly	
Pilot Stage	Nozzle/Flapper	
Pilot Connection	Optional, Internal or External	
Fluid Supply	G631 series servovalves are intended to operate with constant supply pressure	
Supply Pressure	minimum	200 psi [14 bar]
	maximum standard	3,000 psi [210 bar]
Proof Pressure	at "P" port	6,750 psi [473 bar]
	at "T" port	3,000 psi [210 bar]
Rated Flow Tolerance	@ 1,000 psi ΔP_N [%]	± 10
Symmetry	[%]	< 10
Threshold	[%]	< 1.0
Hysteresis	[%]	< 3.0
Null Shift	at $\Delta T = 100^\circ F$ [55°K] [%]	< 4.0
	for every 1,000 psi [70 bar] supply pressure change	< 4.0
Spool Stroke	in [cm]	.05 [.127]
Spool Drive Area	in ² [cm ²]	0.12 [.75]

Typical Response Characteristic Curves measured at 3,000 pilot pressure, fluid viscosity of 100 SUS and fluid temperature of 100°F.

Frequency Response

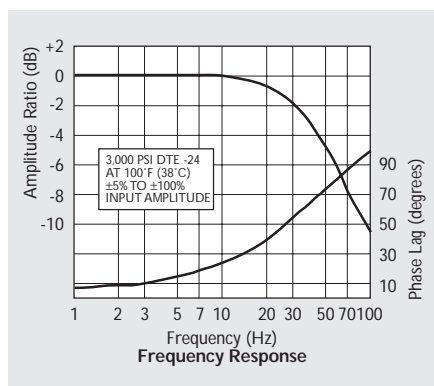

Step Response

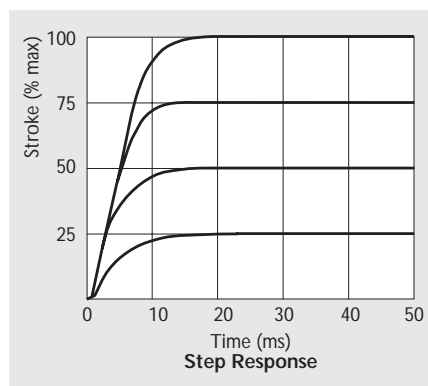

G631 SERIES INSTALLATION DRAWINGS

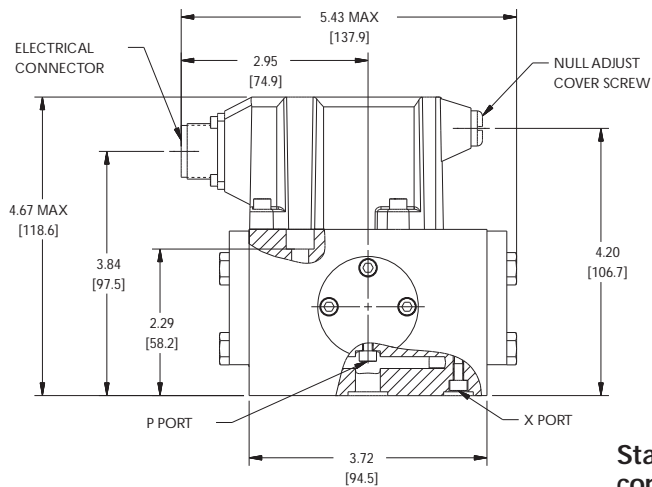
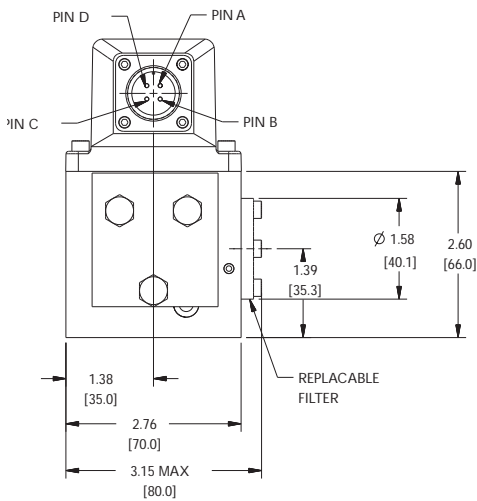
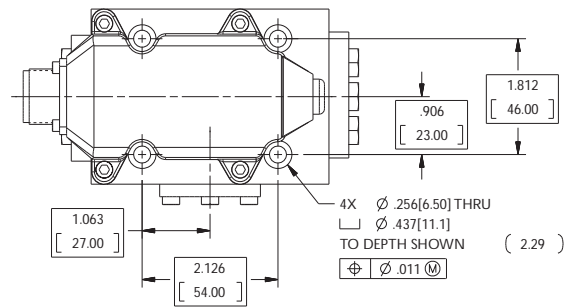

Standard electrical connector mates with MS3106F14S-2S or equivalent.

The mounting manifold must conform to ISO 4401-05-05-0-94*

* Note: Location of X port in valve body does not correspond to ISO standards.

Mounting surface needs to be flat within 0.001 [0.03] TIR and a $\sqrt{32}$ [ΔΔ] finish.

For external null adjust: Flow out of port "A" will increase with clockwise rotation of null adjust screw (1/8 hex key).

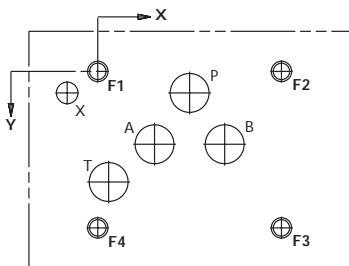

U.S.	P	A	B	T	X	F1	F2	F3	F4
	Ø.44	Ø.44	Ø.44	Ø.44	Ø.25	1/4 - 20	1/4 - 20	1/4 - 20	1/4 - 20
X	1.06	0.66	1.47	0.13	0.31	0	2.13	2.13	0
Y	0.25	0.84	0.84	1.20	0.43	0	0	1.81	1.81

METRIC	P	A	B	T	X	F1	F2	F3	F4
	Ø11.2	Ø11.2	Ø11.2	Ø11.2	Ø6.3	M6	M6	M6	M6
X	27	16.7	37.3	3.2	-8	0	54	54	0
Y	6.3	21.4	21.4	32.5	11.0	0	0	46	46

CONVERSION INSTRUCTION

For operation with internal or external pilot connection.	Pilot flow supply	Screw & Seal Washer Location (M4 X 6 DIN EN ISO 4762)	
	Internal P External X	X	Y
		closed	open
		open	closed

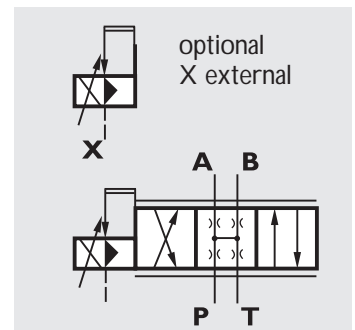

G631 SERIES ELECTRICAL CONNECTIONS

Rated current and coil resistance

A variety of coils are available for G631 Series Servovalves.

Coil connections

A four-pin electrical connector (that mates with an MS3106F14S-2S) is standard. All four torque motor leads are available at the connector so external connections can be made for series, parallel, or single operation.

Servoamplifier

The servovalve responds to input current, so a servoamplifier that has high internal impedance (as obtained with current feedback) should be used. This will reduce the effects of coil inductance and will minimize changes due to coil resistance variations.

ELECTRICAL CONNECTIONS

(Examples with typical G631 series coils)

Coil Resistance	[Ω]	14
Rated Current	[mA]	± 100
Coil Inductance @ 50 Hz	[H]	0.2
Electrical Power	[W]	.14
Polarity for Valve Opening		A and C (+) B and D (-)
P \blacktriangleright B, A \blacktriangleright T		

Parallel

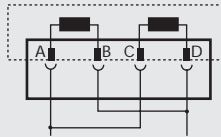

Series

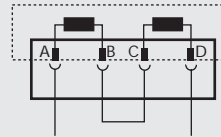

Single

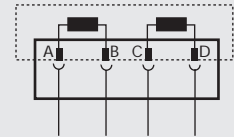

Note: Before applying electrical signals, the pilot stage must be pressurized.

G631 SERIES ORDERING INFORMATION SPARE PARTS AND ACCESSORIES

STANDARD MODELS

Model	Type Designation	Rated Flow (Δ 1,000 psi)		Internal Leakage (at 3,000 psi)		Rated Current (Single Coil)	Nominal Coil Resistance
		gpm	lpm	gpm	lpm	mA	Ohms
G631-3001	P05J GM4VBR	1.0	5.0	< 0.52	< 2.0	100	28
G631-3002	P10J GM4VBR	2.5	10	< 0.60	< 2.3	100	28
G631-3003	P20J GM4VBR	5.0	20	< 0.70	< 2.6	100	28
G631-3004	P40J GM4VBR	10.0	40	< 0.78	< 3.0	100	28
G631-3005	P60J GM4VBR	15.0	60	< 0.86	< 3.2	100	28
G631-3006	P75J GM4VBR	20.0	75	< 0.96	< 3.6	100*	28

* Overdrive more than 10% of rated current (single coil 110 mA) is NOT allowed.

Model Number

G631	•	•	•	•	•	•
------	---	---	---	---	---	---

Optional Feature
Series specification

Model Designation
Assigned at the factory

Factory Identification (Revision Level)

Valve Version
P

Rated Flow Q_N gpm [lpm]		
	At $\Delta P_N = 75$ psi [5 bar] per land	At $\Delta P_N = 500$ psi [35 bar] per land
05	0.4 [1.5]	1 [5]
10	1 [3.7]	2.5 [10]
20	2 [7.5]	5 [20]
40	4 [15]	10 [40]
60	6 [22]	15 [60]
75	8 [30]	20 [75]

Maximum Operating Pressure (P) and Body Material
J | 3,000 psi [210 bar] aluminum

Bushing/Spool Type
O | 4-way / axis cut / linear
D | 4-way / \pm 10% overlap / linear

Type Designation

P	•	•	J	•	G	M	•	V	B	•	-
---	---	---	---	---	---	---	---	---	---	---	---

Special Equipment
- | None

Signals for 100% Spool Stroke
Q | \pm 15 mA (series)
R | \pm 50 mA (series)

Valve Connector
B | Connector over B-side

Seal Material
V | FPM (Viton)

Pilot Connections and Pressure
4 | Internal
5 | External

Spool Position without Electrical Signal
M | Mid-position

Pilot Stage
G | Standard response for valve version P

SPARE PARTS AND ACCESSORIES

Moog Part	Size	Moog Part Number
O-Rings (included in delivery), for P,T,A and B for X	FPM 85 Shore ID 0.472 x 0.079 ID 0.315 x 0.079	G2141-12-20 G2141-8-20
Mating Connector, waterproof IP 65 (not included in delivery)		P/N 49054F14S2S(MS3106F14S-2S)
Flushing Block		P/N B67728-002
Mounting Bolts (not included in delivery)	1/4 - 20 NC x 2-3/4 long (4 pieces) [M6 x 1.0 70 mm]	P/N A31324-144B [B64929-7B70]
Replaceable Filter		P/N A67999-100
Filter Replacement Kit (includes service manual)		P/N B52555RK69K1



Australia	Mulgrave
Brazil	São Paulo
China	Hong Kong
	Shanghai
Denmark	Copenhagen
England	Tewkesbury
Finland	Espoo
France	Rungis



Germany	Böblingen
India	Bangalore
Ireland	Ringaskiddy
Italy	Brescia
	Malnate
Japan	Hiratsuka
Korea	Seoul
Luxembourg	Luxembourg City
Philippines	Baguio
Singapore	Singapore
Spain	Orio
Sweden	Askim
USA	East Aurora

MOOG
Industrial Controls Division
Moog Inc., East Aurora, NY 14052-0018
Telephone: 716/655-3000
Fax: 716/655-1803
Toll Free: 1-800-272-MOOG
www.moog.com