

MOOG

Fastact G G4xx Series Brushless Servomotors



Fastact G/G4xx

Section	Page
Overview	4
Features & Benefits	5
Technical Data	6-15
Options	16-17
Accessories	17
General Info. & Notes	18
Ordering Information	19

This catalog is for users with technical knowledge. To ensure that all necessary characteristics for function and safety of the system are given, the user has to check the suitability of the products described herein.

The products described herein are subject to change without notice. In case of doubt, please contact Moog.

Moog is a registered trademark of Moog Inc. and its subsidiaries. All trademarks as indicated herein are the property of Moog Inc. and its subsidiaries.

©Moog Inc. 2003. All rights reserved.

All changes are reserved.

For the most current information, visit www.moog.com/servomotorsanddrives

Dimensions and tolerances in mm

Dimensioni meccaniche in mm



The motors described herein are UL recognized under file number E 13 7630.



The motors described herein have successfully passed EMC tests required by EC Directive.



The motors described herein follow the design directives according to VDE standards.

Fastact G/G4xx

MOOG BRUSHLESS TECHNOLOGY

For two decades, the name Moog has been associated with brushless servo motors and drives offering the highest dynamics, power density and reliability. The servo motors and drives are designed as a system to deliver superior servo performance. Moog offers a broad range of standard servo motors and drives as well as custom solutions to meet your unique application requirements. Moog brushless servo motors and drives are found on a variety of applications; especially where dynamics, compact size and reliability are important.

G4XX SERIES BRUSHLESS SERVOMOTORS

Moog's G4xx Series motors are electronically commutated synchronous AC motors with permanent magnet field excitation. G4xx Series motors are designed for highly dynamic servo applications where positioning times of 30 mSec or less are often the norm. The G4xx Series offers one of the industry's widest power ranges with standard models available at continuous torque ratings from 0.2 to 75 Nm (2.2 to 664 lb-in). The modular design is supported by a variety of options with Moog's application staff capable of supplying fully customized solutions. All Moog servo motors are manufactured in-house and the use of tight machining tolerances, precision balancing and thorough production testing guarantee a long service life.

Moog Motor Performance Characteristics

In collaborating with a variety of industrial machine designers, Moog realizes what a critical role the application sizing process plays in overall machine design. With global competition forcing designers to do more with less, there is an ever-increasing need to avoid unnecessary margin and "size" exactly to your application needs. It is for these reasons that Moog specifies motor performance characteristics in a manner that makes them practical for designing your system. Motor characteristics are specified under the same environmental conditions in which they will be used, with notes clearly articulating the operating conditions.

The motor performance characteristic contains three elements.

The first element is the continuous torque curve. This curve illustrates the motor torque available at 100% duty cycle under the following conditions:

- operation in still air with ambient temperatures up to 40°C
- winding temperature at 100°C over ambient
- motor front flange attached to a steel mounting plate measuring 300 x 300 x 12 mm

The second element is the peak torque curve. This curve reflects the motor torque available with a 10% duty cycle (1 out of 10 seconds). It is based on years of practical industry experience and is useful for typical servo applications.

The third element is the motor Kt characteristic. The motor Kt characteristic depicts stator saturation at various operating points and can be used to optimize sizing in low duty cycle applications. As shown by the "t" symbol on the motor Kt line, G4xx motors can deliver a low duty cycle "impulse torque" which is typically 30% more than rated peak torque. While motors can be operated reliably at this operating point it is recommended that a member of Moog's application team review the application to ensure thermal restrictions are not violated.

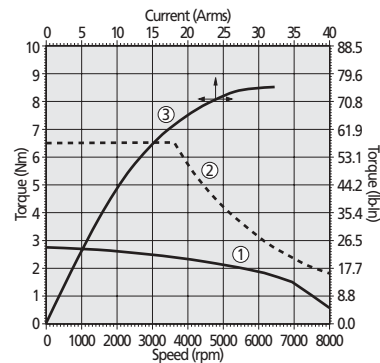

Superior Motor Dynamics Improves Cycle Time

The G4xx Series motor combines a low inertia rotor with an electromagnetic design having exceptional overload capacity. The result is an increase in the effective torque available to accelerate and decelerate the load, enabling higher dynamics and improved cycle times.

G4xx Series motors use a fully laminated, weight-optimized, rotor to provide a significant inertia reduction over conventional solid rotor designs. It is able to achieve a high overload capacity through the use of high-energy rare magnets, a high pole count electrical design, and an efficient thermal construction.

Compact, Lightweight, Construction Simplifies Machine Design

The G4xx Series motor provides high torque in a compact, lightweight, package to achieve both high power density and a high torque-to-weight ratio. The compact, lightweight, package provides greater flexibility and often enables new cost-saving approaches to machine construction. In applications where the motor is mounted on a moving axis the high torque to weight ratio allows greater payloads and/or increased acceleration.

G4xx Series motors leverage an all aluminum motor housing to achieve a significant weight reduction over low cost steel housings. A robust thermal design allows more power to be designed into a small, compact, package.

Proprietary, Low-Cogging, Design Delivers Smooth Low Speed Operation

The G4xx Series motor includes several design enhancements to deliver smooth slow speed performance. The enhancements include the selection of a high pole count (8 to 12 poles) electromagnetic design, a stator with non-symmetric slot count and other proprietary features to minimize cogging.

Ruggedized, Maintenance-Free, Design to Boost Overall System Availability

The G4xx Series motor is designed and manufactured in accordance with strict CE (VDE) standards, using ruggedized components with proven reliability in harsh thermal and shock load environments. These all combine to offer years of reliable, maintenance-free, operation and boost overall system availability.

The use of high reliability resolvers, sealed life-time lubricated bearings, precision balanced rotors (Class G 6.3 of ISO 1940), reduced runout machining tolerances (Class R of DIN 42955-R) and IP67 construction combine to extend service life.

Flexible Design Option Ease Integration

The G4xx Series motor is available with the following options:

- Integral holding brakes
- Resolver (standard) or encoder based feedback
- Plain or slot & key type shafts
- Teflon shaft seal (IP68 sealing)
- Convection (standard) or fan cooling (select models)

Fully Customized Designs Support Unique Application Requirements

Finally, our G4xx Series motors can be customized to meet your unique needs.

The following are typical requests supported by Moog's application staff:

- Custom motor windings
- Custom shafts and flanges
- Custom frameless designs
- Custom connector configurations (including pigtails)
- Custom feedback devices
- Custom designs for unique environments including high temperature, high shock levels, oil and water immersion, areas with explosive gases and areas with elevated radiation levels.

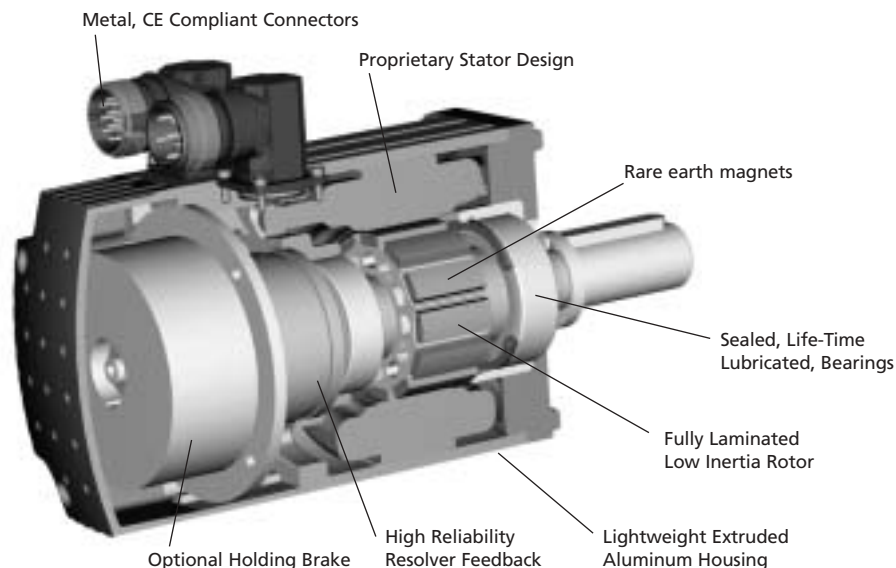

PERFORMANCE SPECIFICATIONS FOR STANDARD MODELS

		Metric [English]	G412-2xx (L05)	G412-4xx (L10)	G412-6xx (L20)	G412-8xx (L40)
Continuous stall torque	M_o	Nm [lb-in]	0.25 [2.2]	0.50 [4.4]	0.95 [8.4]	1.7 [1.5]
Continuous stall current	I_o	Arms	0.65	1.2	2.15	2.85
Peak torque	M_{max}	Nm [lb-in]	0.50 [4.4]	1.4 [12.4]	2.6 [23]	5.0 [44.3]
Peak current	I_{max}	Arms	1.9	3.7	6.4	8.3
Nominal speed	n_N	rpm	8100	7400	6800	6200
Nominal power	P_N	kW [hp]	0.15 [0.20]	0.33 [0.44]	0.53 [0.71]	0.82 [1.1]
Maximum speed	n_{max}	rpm	11500	10000	9000	7000
Torque constant	k_T	Nm/Arms [lb-in/Arms]	0.37 [3.3]	0.42 [3.7]	0.46 [4.1]	0.60 [5.3]
Motor terminal resistance	R_{tt}	Ohm	50.9	20.7	9.9	6.3
Motor inductance	L_{tt}	mH	29.7	15.7	9.1	7.2
Inertia w/o brake	J	kg cm ² [lb-insec ² x 10 ⁻⁴]	0.09 [0.80]	0.13 [1.2]	0.22 [2.0]	0.41 [3.6]
Mass w/o brake	m	kg [lb]	1.0 [2.2]	1.2 [2.7]	1.5 [3.3]	2.3 [5.1]

Notes: Refer to page 17 for notes on performance specifications.

Optional Holding Brake	metric [english]	Option 1	Option 2
Holding torque	Nm [lb-in]	0.90 [8.0]	N/A
Extra weight	kg [lb]	0.18 [0.40]	N/A
Inertia	kg cm ² [lb-insec ² x 10 ⁻⁴]	0.02 [0.18]	N/A
Power requirement	Watt [Watt]	11.0 [11.0]	N/A

For a complete list of options and accessories, see pages 16-18.

PERFORMANCE SPECIFICATIONS FOR STANDARD MODELS

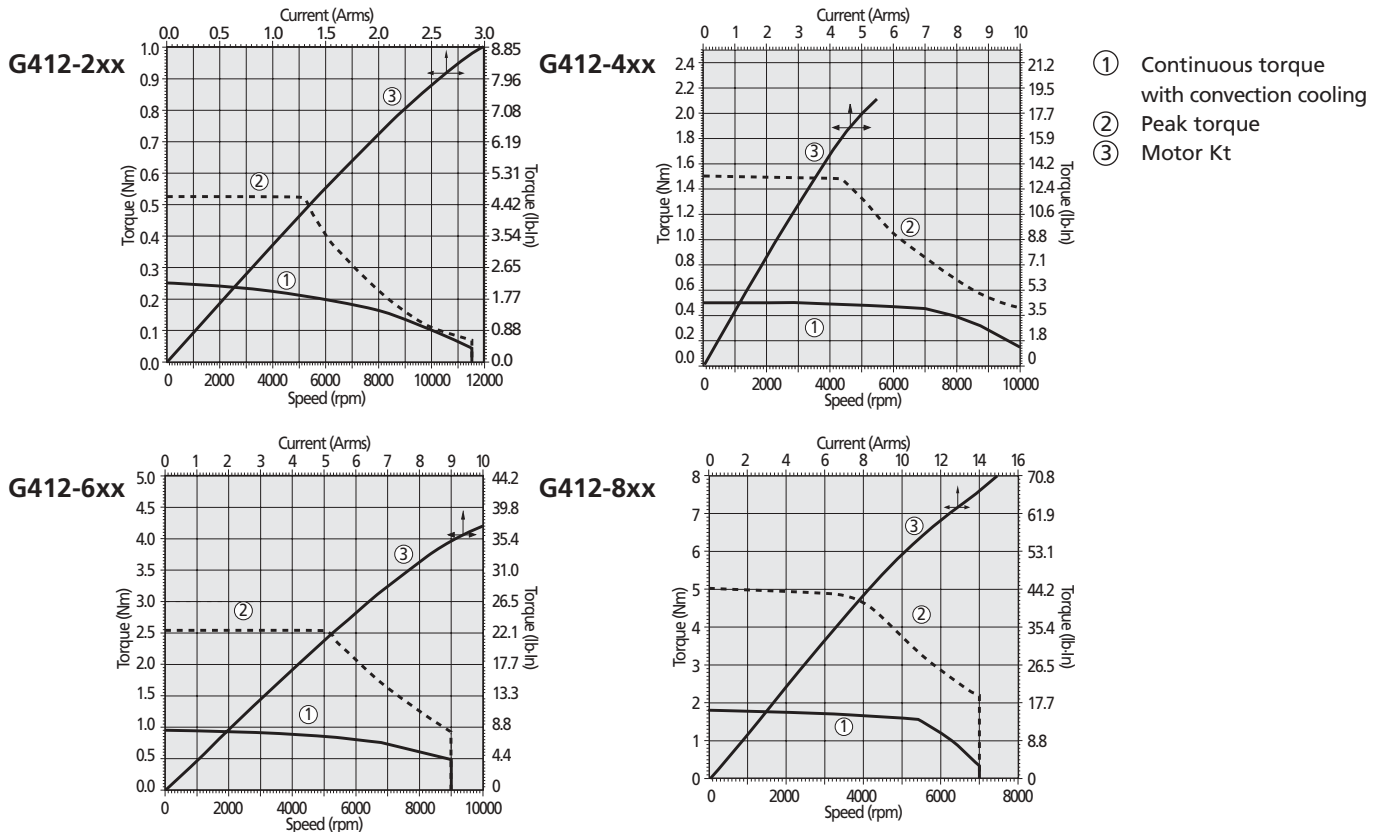

INSTALLATION DIAGRAM

MODEL NO.	Dimension "A"
G412-2xx	109 [4.3]
G412-4xx	122 [4.8]
G412-6xx	147 [5.8]
G412-8xx	198 [7.8]

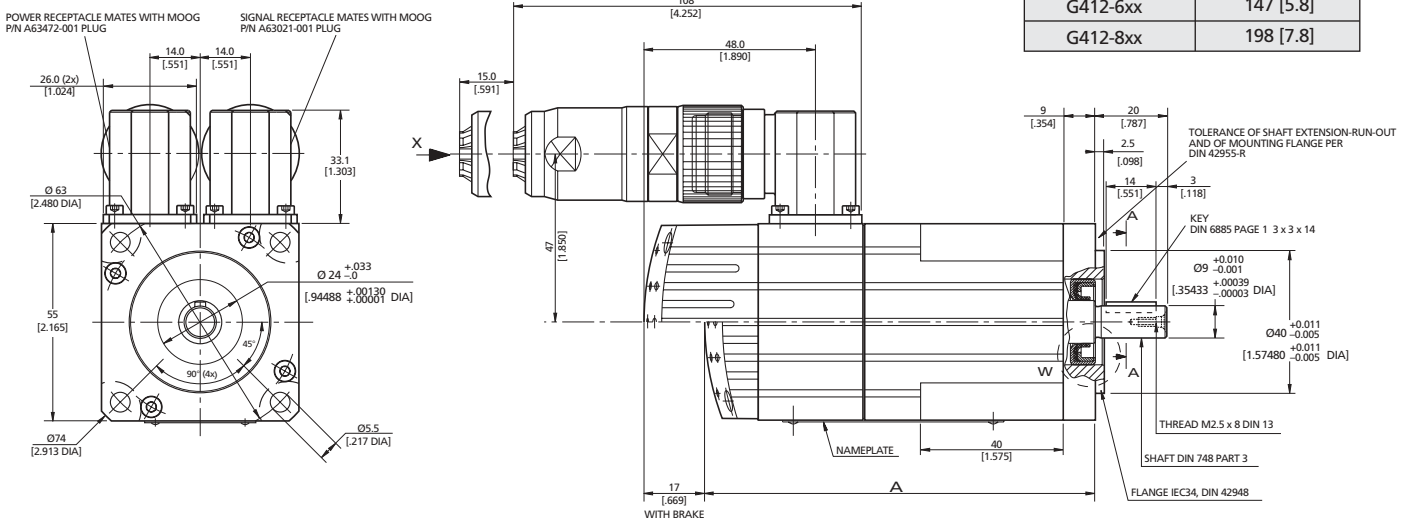

Dimensions: mm [in]

WIRING DIAGRAM

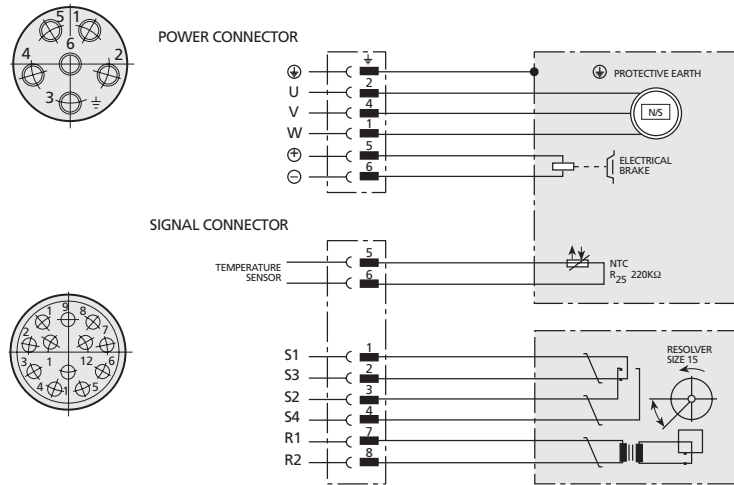

BEARING LOAD DIAGRAM

Maximum Permissible Shaft Load

The maximum permissible radial load depends on desired service length. The bearing load curves illustrated support an operational life of 20,000 hours (L10h) with axial loads up to 75 N. Consult Moog for extended service life requirements or alternate load conditions.

Notes:

1. Load capacity referenced to middle of output shaft.
2. Maximum axial load during installation: 150N.

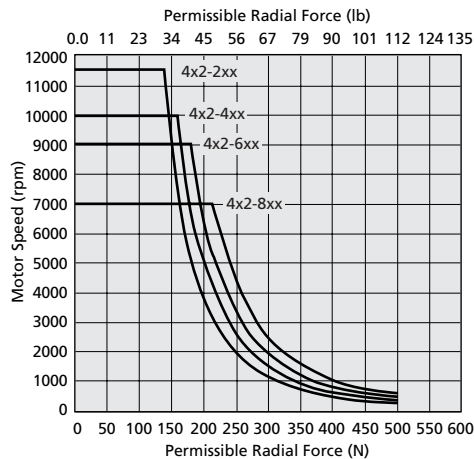

PERFORMANCE SPECIFICATIONS FOR STANDARD MODELS

		Metric [English]	G413-2xx (LO5)	G413-4xx (L15)	G413-6xx (L25)	G413-8xx (L40)
Continuous stall torque	M_o	Nm [lb-in]	0.60 [5.3]	1.65 [14.6]	2.55 [22.7]	3.7 [32.7]
Continuous stall current	I_o	Arms	1.6	3.2	3.4	4.2
Peak torque	M_{max}	Nm [lb-in]	1.5 [13.3]	4.7 [41.6]	8.5 [75.2]	13.0 [115]
Peak current	I_{max}	Arms	4.6	10.6	12.4	16.3
Nominal speed	n_N	rpm	8800	6300	4800	3900
Nominal power	P_N	kW [hp]	0.45 [0.60]	0.95 [1.3]	1.15 [1.5]	1.4 [1.9]
Maximum speed	n_{max}	rpm	10500	8000	5500	4500
Torque constant	k_T	Nm/Arms [lb-in/Arms]	0.40 [3.5]	0.53 [4.7]	0.75 [6.6]	0.90 [8.0]
Motor terminal resistance	R_{tt}	Ohm	15.2	4.9	5.1	4.1
Motor inductance	L_{tt}	mH	18.8	8.5	10.3	8.9
Inertia w/o brake	J	kg cm ² [lb-insec ² x 10 ⁻⁴]	0.16 [1.4]	0.39 [3.5]	0.62 [5.5]	0.97 [8.6]
Mass w/o brake	m	kg [lb]	1.4 [3.1]	2.0 [4.4]	2.6 [5.7]	3.5 [7.7]

Notes: Refer to page 17 for notes on performance specifications.

Optional Holding Brake	metric [english]	Option 1	Option 2
Holding torque	Nm [lb-in]	2 [17.7]	4.5 [39.9]
Extra weight	kg [lb]	0.20 [0.44]	0.32 [0.70]
Inertia	kg cm ² [lb-insec ² x 10 ⁻⁴]	0.007 [0.62]	0.18 [1.59]
Power requirement	Watt [Watt]	11.0 [11.0]	12.0 [12.0]

For a complete list of options and accessories, see pages 16-18.

PERFORMANCE SPECIFICATIONS FOR STANDARD MODELS

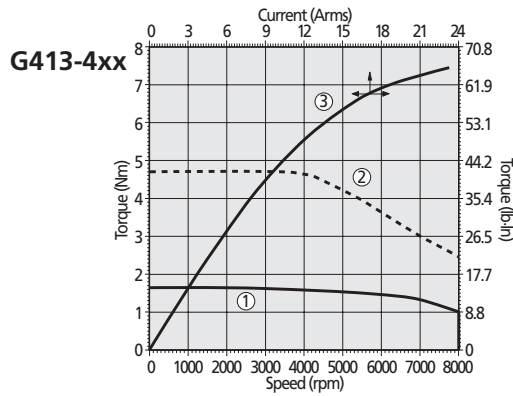
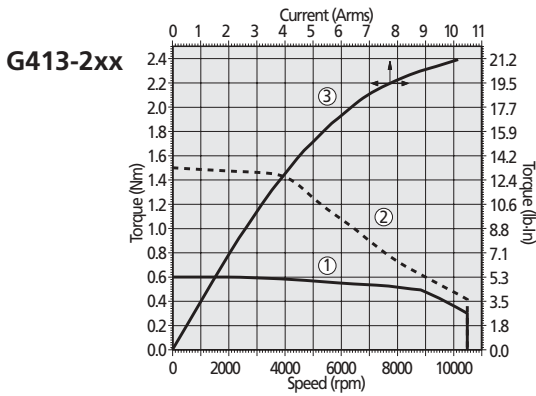

- ① Continuous torque with convection cooling
- ② Peak torque
- ③ Motor Kt

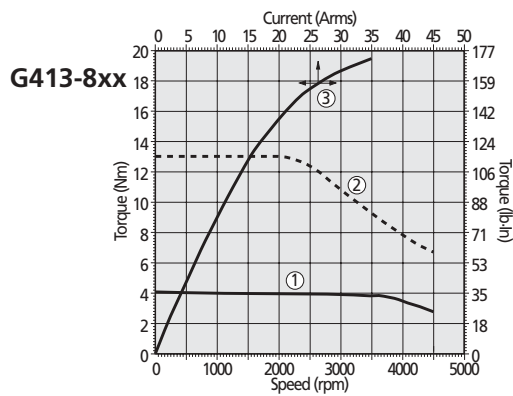
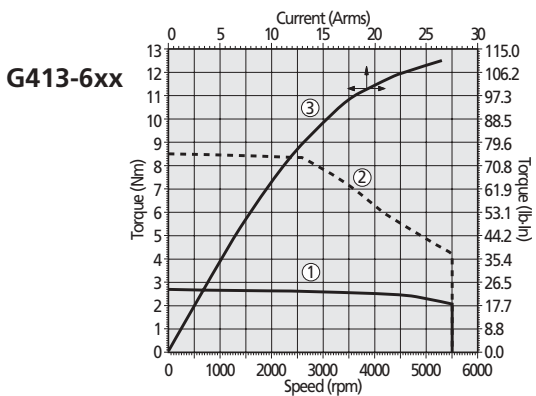

INSTALLATION DIAGRAM

MODEL NO.	Dimension "A"
G413-2xx	114 [4.5]
G413-4xx	140 [5.5]
G413-6xx	165 [6.5]
G413-8xx	203 [8.0]

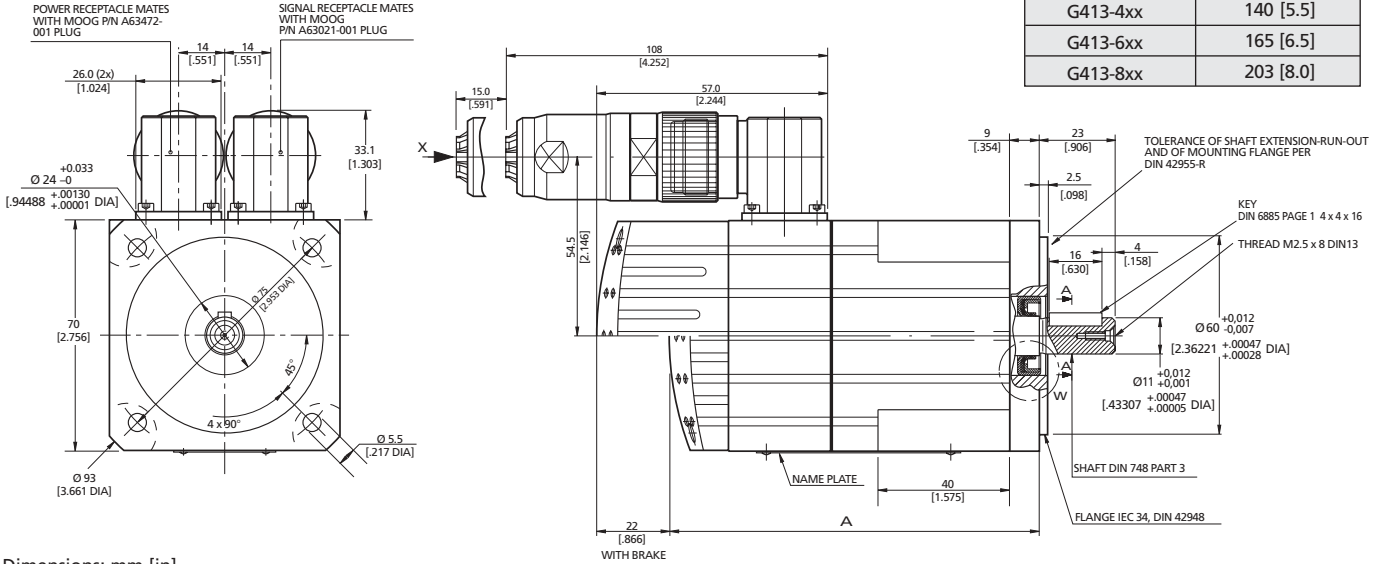

Dimensions: mm [in]

WIRING DIAGRAM

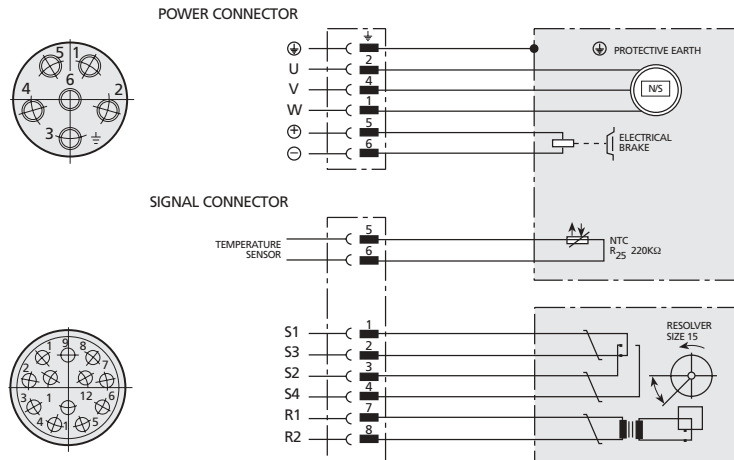

BEARING LOAD DIAGRAM

Maximum Permissible Shaft Load

The maximum permissible radial load depends on desired service length. The bearing load curves illustrated support an operational life of 20,000 hours (L10h) with axial loads up to 75 N. Consult Moog for extended service life requirements or alternate load conditions.

Notes:

1. Load capacity referenced to middle of output shaft.
2. Maximum axial load during installation: 150 N.

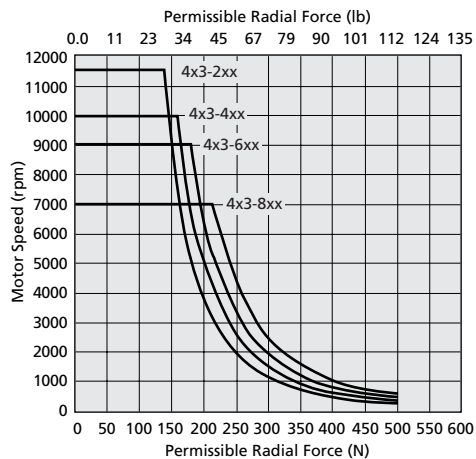

PERFORMANCE SPECIFICATIONS FOR STANDARD MODELS

	Metric [English]	G414-2xx (L05)	G414-4xx (L10)	G414-6xx (L20)	G414-8xx (L40)	G414-9xx (L60)	
Continuous stall torque ¹	M _o	Nm [lb-in]	1.3 [11.5]	2.6 [23.0]	4.7 [41.6]	8.2 [72.6]	12.5 [110.6]
Continuous stall current ¹	I _o	Arms	3.1	4.8	6.7	9.2	9.6
Peak torque ²	M _{max}	Nm [lb-in]	3.2 [26.5]	6.5 [57.5]	12.5 [110.6]	22.0 [195]	35.0 [309.8]
Peak current ²	I _{max}	Arms	9.0	15.0	20.0	28.0	30.0
Nominal speed ⁴	n _N	rpm	5800	5500	4300	3500	2800
Nominal power ⁴	P _N	kW [hp]	0.58 [0.78]	0.95 [1.3]	1.8 [2.4]	2.3 [3.1]	2.7 [3.6]
Maximum speed ⁶	n _{max}	rpm	10000	8000	5800	4700	3280
Torque constant	k _T	Nm/Arms [lb-in/Arms]	0.42 [3.7]	0.56 [5.0]	0.8 [6.9]	0.99 [8.8]	1.3 [11.5]
Motor terminal resistance ⁷	R _{tt}	Ohm	5.1	2.7	1.5	0.90	0.96
Motor inductance ⁷	L _{tt}	mH	8.52	5.78	4.6	3.5	4.0
Inertia w/o brake	J	kg cm ² [lb-insec ² x 10 ⁻⁴]	1.05 [9.3]	1.55 [13.7]	2.6 [23.0]	4.7 [41.6]	6.8 [60.2]
Mass w/o brake	m	kg [lb]	3.0 [6.6]	3.6 [7.9]	4.7 [10.4]	6.9 [15.2]	9.1 [20.1]

Notes: 1-7 refer to page 17.

Optional Holding Brake	metric [english]	Option 1	Option 2
Holding torque	Nm [lb-in]	9.0 [80.0]	18.0 [159.6]
Extra weight	kg [lb]	0.53 [1.2]	0.75 [1.7]
Inertia	kg cm ² [lb-insec ² x 10 ⁻⁴]	0.54 [4.8]	1.0 [8.9]
Power requirement	Watt [Watt]	18.0 [18.0]	15.6 [15.6]

For a complete list of options and accessories, see pages 16-18.

PERFORMANCE SPECIFICATIONS FOR STANDARD MODELS

G414-2xx

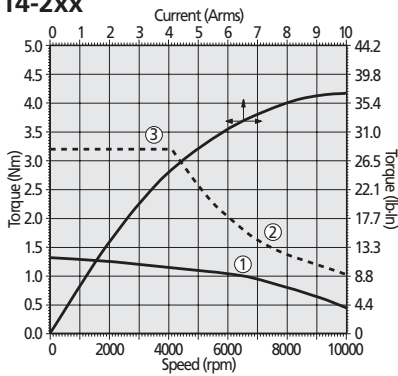

G414-4xx

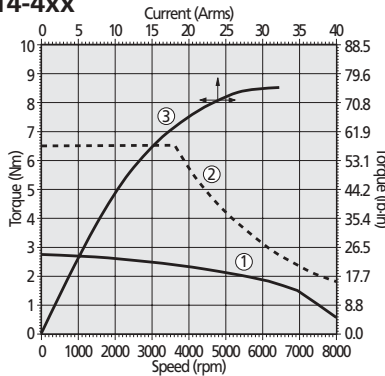

G414-6xx

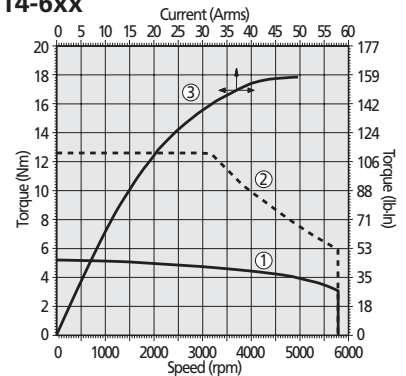

G414-8xx

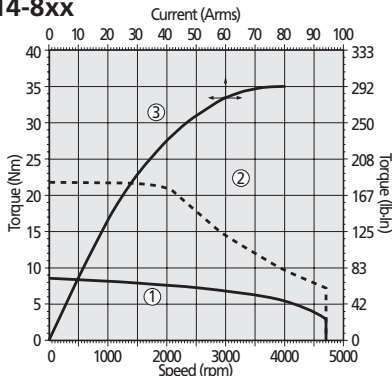

G414-9xx

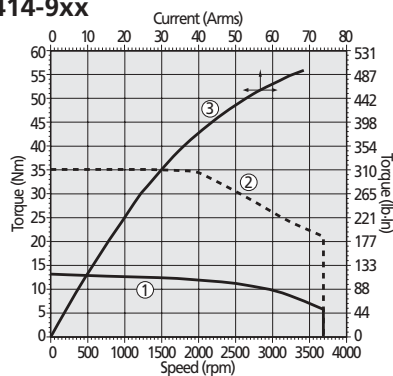

- ① Continuous torque with convection cooling
- ② Peak torque
- ③ Motor Kt

INSTALLATION DIAGRAM

MODEL NO.	Dimension "A"
G414-2xx	133 [5.2]
G414-4xx	146 [5.8]
G414-6xx	171 [6.7]
G414-8xx	222 [8.8]
G414-9xx	273 [10.8]

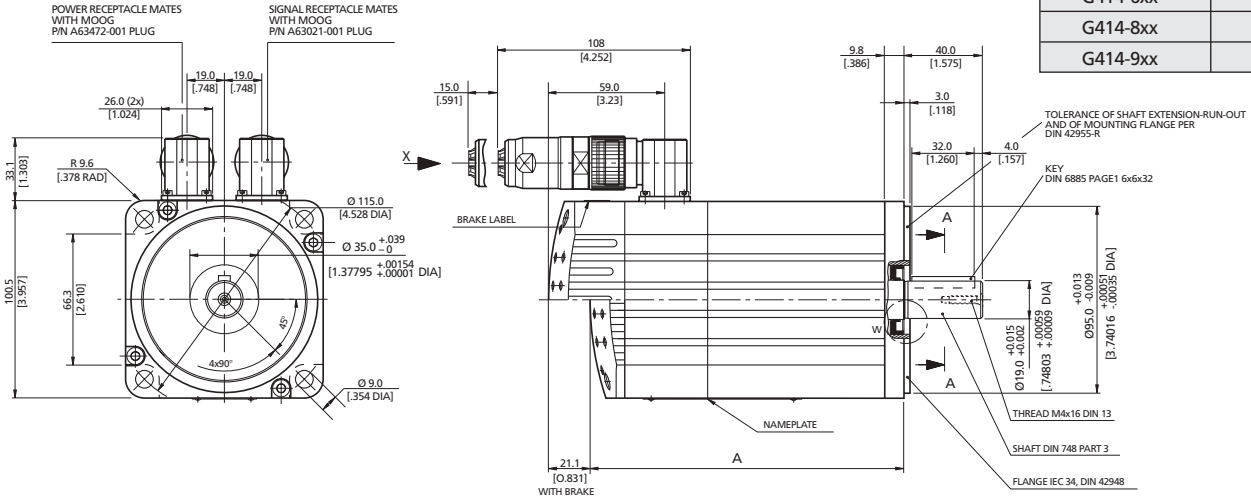

Dimensions: mm [in]

WIRING DIAGRAM

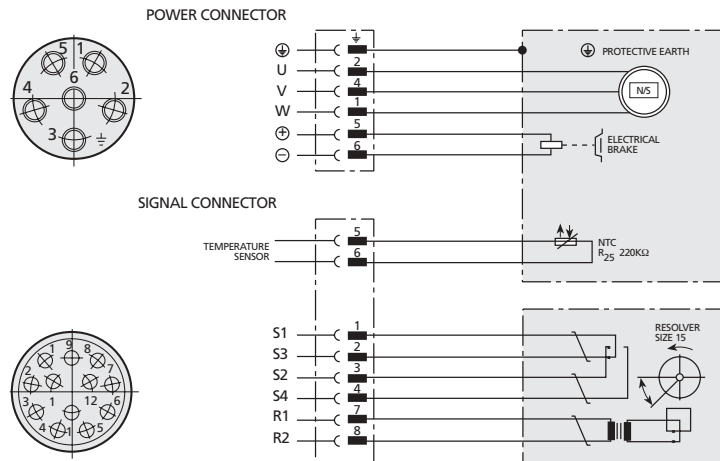

BEARING LOAD DIAGRAM

Maximum Permissible Shaft Load

The maximum permissible radial load depends on desired service length. The bearing load curves illustrated support an operational life of 20,000 hours (L10h) with axial loads up to 150 N. Consult Moog for extended service life requirements or alternate load conditions.

Notes:

1. Load capacity referenced to middle of output shaft.
2. Maximum axial load during installation: 300 N.

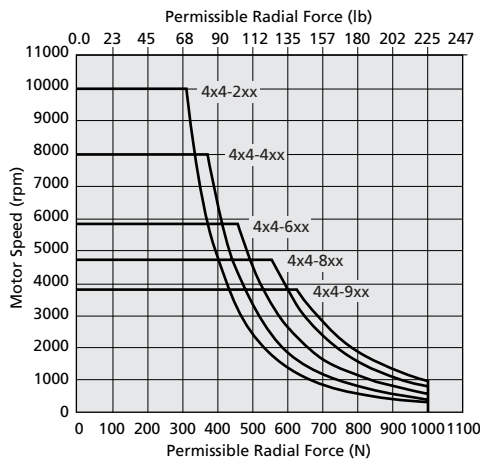

PERFORMANCE SPECIFICATIONS FOR STANDARD MODELS

		Metric [English]	G415-2xx (L10)	G415-4xx (L20)	G415-6xx (L30)	G415-8xx (L50)
Continuous stall torque	M_o	Nm [lb-in]	5.8 [51.3]	11.2 [99.1]	16.6 [147]	25.0 [221.3]
Continuous stall current	I_o	Arms	9.5	11.0	12.9	14.8
Peak torque	M_{max}	Nm [lb-in]	12.2 [108]	25.8 [230]	40.0 [354]	60.0 [531]
Peak current	I_{max}	Arms	24.0	33.0	38.0	43.0
Nominal speed	n_N	rpm	4800	3500	2700	2200
Nominal power	P_N	kW [hp]	2.3 [3.1]	3.4 [4.5]	4.0 [5.3]	4.6 [6.2]
Maximum speed	n_{max}	rpm	6800	4200	3300	2400
Torque constant	k_T	Nm/Arms [lb-in/Arms]	0.61 [5.4]	1.02 [9]	1.29 [11.4]	1.69 [15]
Motor terminal resistance	R_{tt}	Ohm	0.86	0.74	0.64	0.56
Motor inductance	L_{tt}	mH	4.3	4.8	4.8	5.4
Inertia w/o brake	J	kg cm ² [lb-insec ² x 10 ⁻⁴]	4.6 [40.7]	8.0 [70.8]	11.5 [102]	18.4 [163]
Mass w/o brake	m	kg [lb]	7.7 [17.0]	9.9 [21.8]	12.1 [26.7]	16.6 [36.6]

Notes: Refer to page 17 for notes on performance specifications.

Optional Holding Brake	metric [english]	Option 1	Option 2
Holding torque	Nm [lb-in]	18.0 [159.6]	3.0 [266]
Extra weight	kg [lb]	0.75 [1.7]	1.1 [2.43]
Inertia	kg cm ² [lb-insec ² x 10 ⁻⁴]	1.0 [8.9]	3.6 [31.7]
Power requirement	Watt [Watt]	15.6 [15.6]	17.0 [17.0]

For a complete list of options and accessories, see pages 16-18.

PERFORMANCE SPECIFICATIONS FOR STANDARD MODELS

G415-2xx

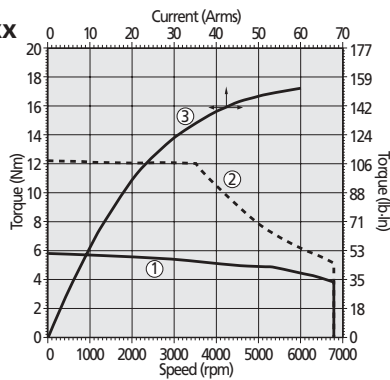

G415-4xx

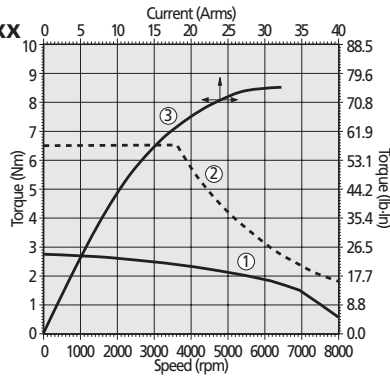

- ① Continuous torque with convection cooling
- ② Peak torque
- ③ Motor Kt

G415-6xx

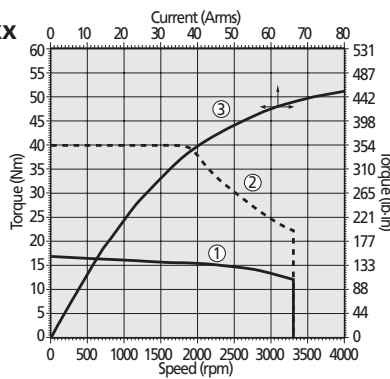

G415-8xx

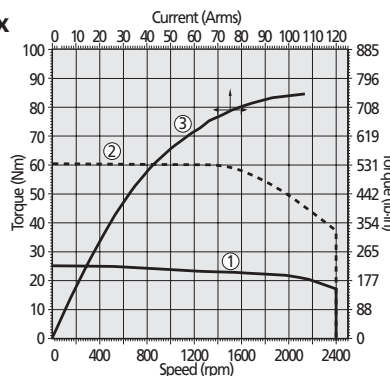

INSTALLATION DIAGRAM

MODEL NO.	Dimension "A"
G415-2xx	170 [6.7]
G415-4xx	195 [7.7]
G415-6xx	220 [8.7]
G415-8xx	271 [10.7]

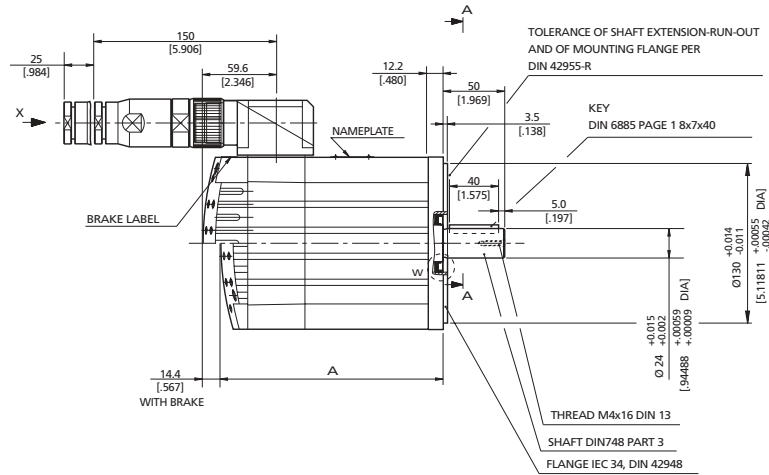
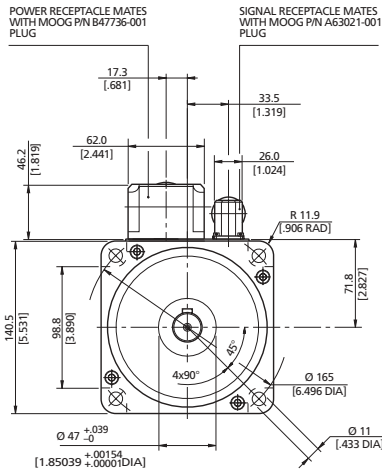

Dimensions: mm [in]

WIRING DIAGRAM

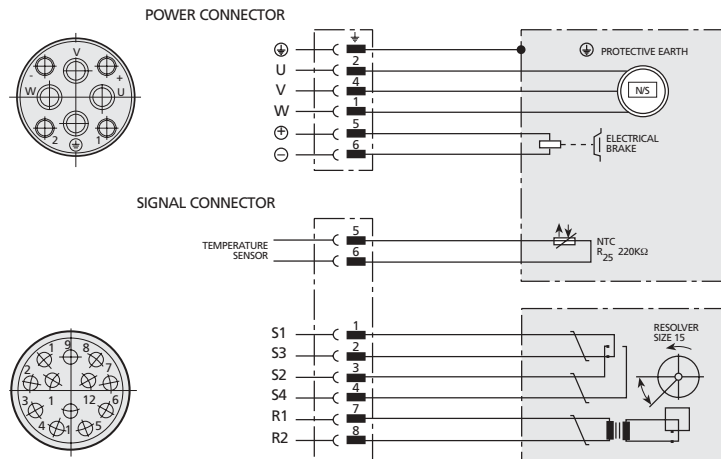

BEARING LOAD DIAGRAM

Maximum Permissible Shaft Load

The maximum permissible radial load depends on desired service length. The bearing load curves illustrated support an operational life of 20,000 hours (L10h) with axial loads up to 200 N. Consult Moog for extended service life requirements or alternate load conditions.

Notes:

1. Load capacity referenced to middle of output shaft.
2. Maximum axial load during installation: 400 N.

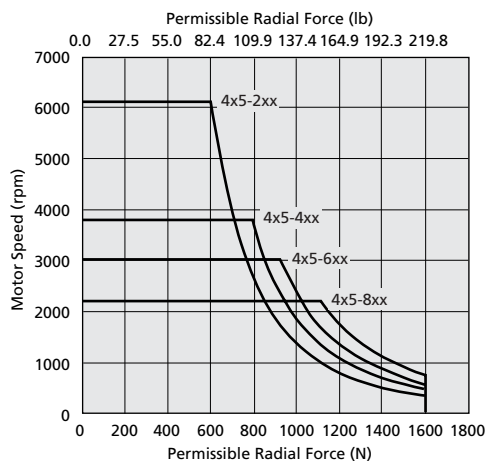

PERFORMANCE SPECIFICATIONS FOR STANDARD MODELS

	Metric [English]	G416-2xx (L15)	G416-4xx (L30)	G416-6xx (L45)	G416-8xx (L60)	G416-9xx (L90)	
Continuous stall torque	M_o	Nm [lb-in]	14.0 [124]	27.0 [239]	39.0 [345]	51.0 [451]	75.0 [663.8]
Continuous stall current	I_o	Arms	22.0	30.0	38.0	43.0	47.0
Peak torque	M_{max}	Nm [lb-in]	37.0 [327]	73.0 [646]	108 [956]	146 [1292]	200 [1770]
Peak current	I_{max}	Arms	72.0	95.0	117	134	141
Nominal speed	n_N	rpm	4000	3000	2500	2200	2200
Nominal power	P_N	kW [hp]	3.8 [5.1]	4.9 [6.5]	6.7 [9.0]	7.8 [10.5]	11 [14.7]
Maximum speed	n_{max}	rpm	6300	4700	3900	3300	3000
Torque constant	k_T	Nm/Arms [lb-in/Arms]	0.64 [5.7]	0.90 [8.0]	1.03 [9.1]	1.19 [10.5]	1.57 [13.9]
Motor terminal resistance	R_{tt}	Ohm	0.23	0.14	0.11	0.10	0.11
Motor inductance	L_{tt}	mH	1.9	1.5	1.5	1.5	1.7
Inertia w/o brake	J	kg cm ² [lb-insec ² x 10 ⁻⁴]	27.2 [241]	52.1 [461]	77.0 [682]	102 [903]	152 [1345]
Mass w/o brake	m	kg [lb]	15.1 [33.3]	21.1 [46.5]	27.1 [59.7]	33.1 [73.0]	40.0 [88.2]

Notes: Refer to page 17 for notes on performance specifications.

Optional Holding Brake	metric [english]	Option 1	Option 2
Holding torque	Nm [lb-in]	30 [266]	72 [636]
Extra weight	kg [lb]	1.1 [2.48]	2.85 [6.4]
Inertia	kg cm ² [lb-insec ² x 10 ⁻⁴]	3.6 [31.7]	16 [142]
Power requirement	Watt [Watt]	17 [17]	40 [40]

For a complete list of options and accessories, see pages 16-18.

PERFORMANCE SPECIFICATIONS FOR STANDARD MODELS

G416-2xx

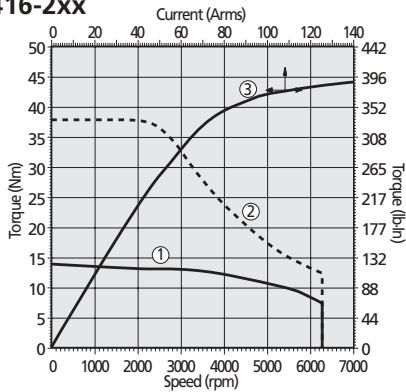

G416-4xx

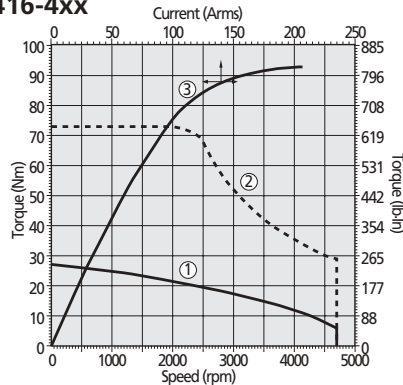

G416-6xx

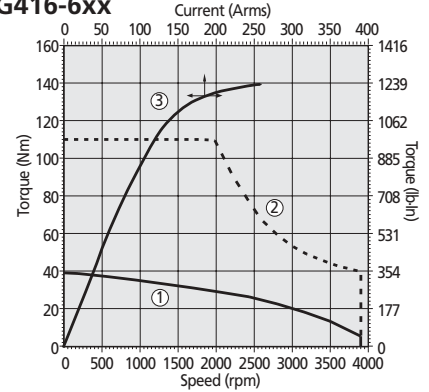

G416-8xx

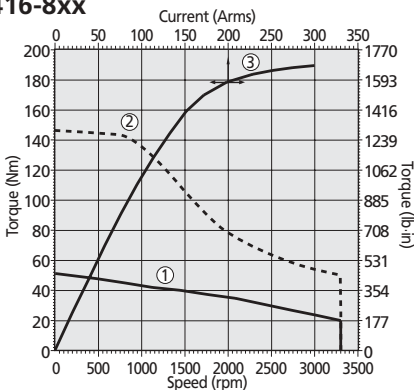

G416-9xx

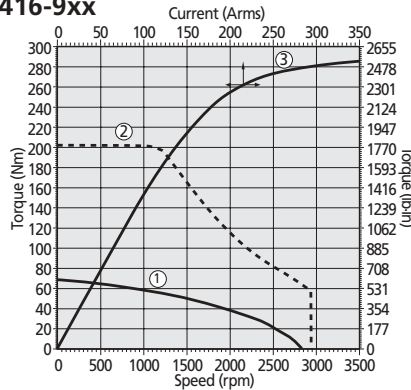

- ① Continuous torque with convection cooling
- ② Peak torque
- ③ Motor Kt

INSTALLATION DIAGRAM

MODEL NO.	Dimension "A"
G416-2xx	187 [7.3]
G416-4xx	225 [8.9]
G416-6xx	263 [10.3]
G416-8xx	301 [11.9]
G416-9xx	377 [14.8]

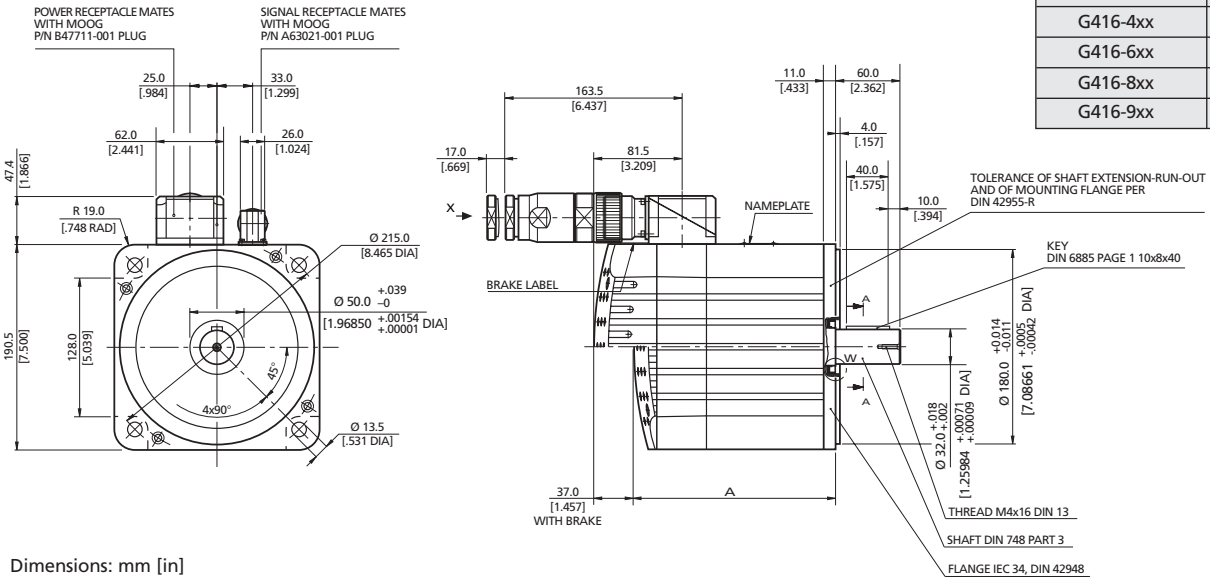

Dimensions: mm [in]

WIRING DIAGRAM

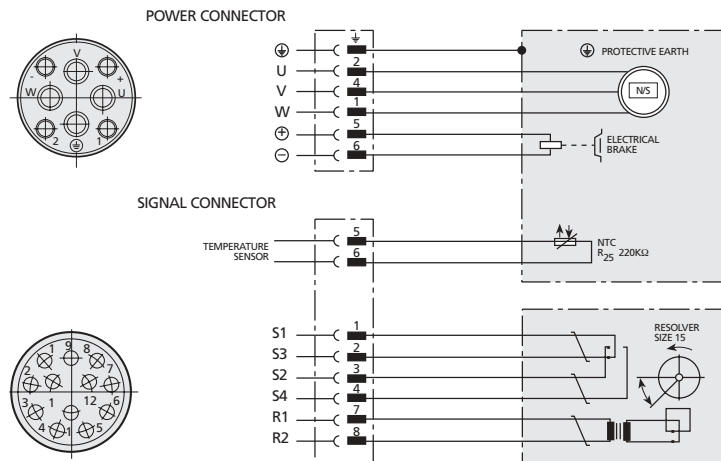

BEARING LOAD DIAGRAM

Maximum Permissible Shaft Load

The maximum permissible radial load depends on desired service length. The bearing load curves illustrated support an operational life of 20,000 hours (L10h) with axial loads up to 250 N. Consult Moog for extended service life requirements or alternate load conditions.

Notes:

1. Load capacity referenced to middle of output shaft.
2. Maximum axial load during installation: 500 N.

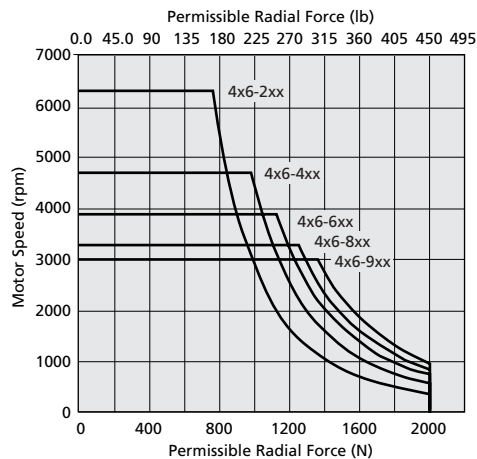

Moog's G4xx motors are available with a variety of standard and custom options to address the unique requirements of your application. Moog's motor design and application teams are continually introducing new

options to address the changing needs of the market place. As a result, if you need something that's not presently listed, don't hesitate to contact your local sales office – chances are we already have it.

STANDARD OPTIONS

Integral Holding Brake

Holding brakes are available for all standard G4xx motors. The brake is a permanent magnet style that is designed to hold the axis in position even with power removed. This is especially useful in applications where the motor is on an axis controlling a weight-induced load (e.g., vertical axis on a gantry robot). Note, the brake is a holding brake and is not designed to stop dynamic loads. The servo drive is required to decelerate the axis and hold position before the brake is engaged.

The integral holding brake requires a regulated 24 VDC supply (see Motor Accessories) for proper operation. Brake power connections are through the standard motor power connector. Refer to motor technical data for brake current requirements.

Encoder Adapter

Encoder adapters are available as an option to all standard G4xx motors. The encoder adapter incorporates the industry standard syncro flange mechanical interface providing compatibility with incremental and absolute encoders from a variety of suppliers (Heidenhain, Stegmann, Hengstler, ...etc.). The unique mechanical design allows standard encoders to be used without thermally derating motor performance.

Fan Cooling

To supply high dynamics in high duty cycle applications, Moog offers optional fan cooling on select G4xx motor models. Fan cooling delivers up to 50% greater continuous torque output without increasing motor inertia.

Fans are powered by an unregulated 24 VDC supply (see Motor Accessories) with dedicated power connector. Current requirements are 1 ADC per motor.

Fan cooling is available as an option on the following motors:

- G4x4-8xx
- G4x4-9xx
- G4x5-8xx
- G4x6-8xx
- G4x6-9xx



Shaft Options

Standard G4xx motors are available with plain or slot and key metric shafts per NEMA MG7. For custom motor shafts such as spline or english dimension shafts see Custom Options.

Shaft Seal

In applications where the shaft/flange mating surface is immersed in fluids, a shaft seal is required to maintain motor integrity. Moog offers PTFE (teflon) type shaft seals which have excellent operating characteristics (resistant to shrinkage and thermal stress).

CUSTOM OPTIONS

Motor Windings

Moog's standard G4xx motors are designed to address the needs of most dynamic motion control applications. However, Moog recognizes that OEMs have unique needs which can not always be addressed by catalog products. This is why Moog offers custom motor windings. Custom motor windings may be used to optimize motor performance in applications with non-standard bus voltages or deliver customized performance characteristics for applications with unique speed or current requirements.

Frameless Options

In addition to offering our compact G4xx motors in a frameless package, Moog's motor design and application teams are able to develop specialty motors meeting your unique specifications. Moog's high power density design allows our motor to be packaged in envelopes where other motors simply won't fit. In addition, Moog's design expertise includes motors adapted for operation in extreme environments:

- Elevated Temperatures
- Explosive/Flammable Gases
- Underwater Application
- High Shock Loads
- Radiation Zones



Our G4xx frameless motor offering is based on the following standard stator dimensions:

Model	Stator Outer Diameter (nominal) mm [in]
G412	48.0 [1.9]
G413	63.5 [2.5]
G414	91.9 [3.6]
G415	130 [5.1]
G416	178 [7.0]

ACCESSORIES

To speed your design cycle, Moog offers a variety of accessories which have been specified and tested for compatibility with our motors and drives. These accessories will also minimize assembly activities, allowing you to reduce production time.

Custom Shafts and Flanges

To support legacy products or meet unique application needs, moog's modular G4xx motor design is capable of supporting custom shafts (length, diameter or spline fittings) and custom flanges.



Custom Connectors

Moog's standard G4xx motors are equipped with quick connect right angle connectors. In applications where straight connectors or flying leads are required, Moog can adapt the design to best meet your needs.

Custom Feedback Options

In addition to encoder adapter kits (see Standard Options), Moog can support requests for special feedback devices. Options presently offered include integral encoders (incremental or absolute), tachometers and hall sensors.

Custom Coatings

Moog's standard G4xx motors are rated for spraydown environments. Moog is capable of coating the motors with FDA required coatings for applications in the food processing industry.

- Recommended Drives: see Moog's drives catalogs
- To obtain preassembled motor cables, crimp tools, power supplies, please contact Moog staff.

GENERAL INFORMATION

1. Motors designed to EN 60034 (VDE 0530).
2. Runout class R per DIN 42955-R.
3. Rotors balanced to Class G 6.3 per ISO 1940.
4. Sealing to IP65 (excluding shaft) with Moog specified mating connectors.
5. Operating ambient temperature -40 to +40°C (up to 130°C with derated output).
6. Class F winding insulation.
7. Motor flange dimensions per IEC 34, NEMA MG7, DIN 42948, ISO 286.
8. Motor shaft dimensions per DIN 748.
9. Motor shaft keyway per DIN 6885.
10. Resolver electrical specifications as follows:
 - a. Resolver Type: Transmitter
 - b. Pole Count: 2
 - c. Input Voltage: 4 Vrms
 - d. Carrier frequency: 3.4 to 8 kHz
 - e. Input Current: 35 mA max.
 - f. Transformer Ratio: 0.5
11. The following metric conversions were used:
 - a. 1 Nm = 8.85 lb-in
 - b. 1 N = 0.225 lb
 - c. 1 kW = 1.34 hp
 - d. 1 kg-cm² = 8.85 lb-in-sec² x 10⁻⁴
12. NTC thermistor in the winding for temperature monitoring

NOTES

1. Continuous ratings based upon:
 - a. Operation in still air with ambient temperatures at 25°C.
 - b. Winding temperature at 100°C over ambient.
 - c. Motor front flange attached to a steel mounting plate measuring 300 x 300 x 12 mm.
2. Peak ratings based on:
 - a. Duty cycle of 10% (1 out of 10 seconds).
 - b. Iron saturation of 15% or less.
3. Kt-line show non-linearity between current and torque at high end.
4. Nominal speed and power values at maximum continuous output power with conditions per note 1.
5. Maximum speed based on back EMF of 360 VDC.
6. Resistance and inductance measurement based on "cold" values (i.e., measured at 25°C).
7. Current ratings are Arms per phase.
8. Motor performance as measured with Moog's T200 servo drive. Performance with other drives may vary.
9. Specification tolerances are ±10%.

ORDERING INFORMATION

Fas G/G4xx

G4

Voltage	
Code	Description
1	Low
6	High

Frame Size	
Code	Description
2	55 mm Flange
3	70 mm Flange
4	100 mm Flange
5	140 mm Flange
6	190 mm Flange

Stack Length					
Code	G412	G413	G414	G415	G416
2	L05	L05	L05	L10	L15
4	L10	L15	L10	L20	L30
6	L20	L25	L20	L30	L45
8	L40	L40	L40	L50	L60
9	-	-	L60	L70	L90

Brake Option					
Code	G412	G413	G414	G415	G416
0	No	No	No	No	No
1	0,9	2	9	18	30
2	-	4,5	18	30	72

Shaft Configuration		
Code	Shaft End	Shaft Seal
4	Keyway	No
5	Keyway	Yes
6	Plain	No
7	Plain	Yes
X	Custom	No
Y	Custom	Yes

Revision Index



**Argentina
Australia
Austria
Brazil
China
Finland
France
Germany
India
Ireland**



**Italy
Japan
Korea
Luxembourg
Norway
Russia
Singapore
South Africa
Spain
Sweden
United Kingdom
USA**

MOOG

Moog Italiana S.r.l.
Electric Division
Via Avosso, 94-16015 Casella (Genova) - Italy
Telephone: (+39) 010 96711
Fax: (+39) 010 9671280
For the location nearest to you, contact
www.moog.com/worldwide

**COMPANY WITH INTEGRATED
MANAGEMENT SYSTEM
CERTIFIED BY DNV
=ISO 9001/ISO 14001=**

Fastact G/G4xx CAS-022 EN 0903