

Description

The Moog Buffer Amplifier interfaces between standard PLC analogue input and output modules, on one side, and a position transducer and a Moog valve, on the other. It simplifies the use of a PLC in closing position loops.

The Buffer Amplifier solves the common problem of the $\pm 10V$ PLC output being incompatible with the valve drive requirements.

Digital noise from the PLC $\pm 10V$ output is filtered with a switch selectable first order filter and converted to two switch selectable outputs. The first is $\pm 10V$ and the second is a switch selectable current output of $\pm 5mA$ to $\pm 100 mA$. This allows for most Moog electrical feedback (efb) and mechanical feed-back (mfb) valves.

The filter and valve current selector switches can have more than one of each selected, so the selected values are summed. For example, selecting 50 and 30 mA together will give a full scale output of 80 mA.

The position transducer signal is filtered by the Buffer Amplifier, before being passed through to the PLC analogue input module. This ensures transducer and external noise cannot upset the closed loop.

The Buffer Amplifier is housed in a compact DIN rail mounting enclosure and requires a 24 V supply. Front panel test points and valve drive LEDs facilitate commissioning and trouble shooting.

Features

- Compact, DIN rail mounting
- Outputs to suit most Moog valves
- Transducer (probe), valve and 0V test points
- Vv and Iv LED valve drive indicators
- Switch selections sum for filter and valve current
- Transducer (probe) signal filter
- +24V supply
- Switch selectable voltage or current output
- Switch selectable valve drive filter
- Switch selectable current output
- CE marked

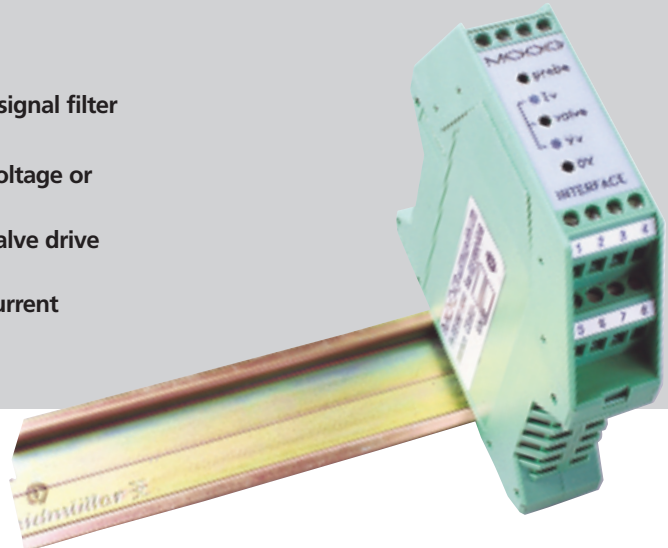

Specifications

Valve drive input:	0 to $\pm 10V$
Valve drive outputs:	0 to $\pm 10V$ 0 to $\pm 100mA$ max
Valve drive current selections:	$\pm 5, 10, 20, 30$ & $50 mA$
Current signal output headroom:	$\pm 10V$ min
Valve drive test point:	$Z_o = 10K$
Probe test point:	$Z_o = 10K$
Vv LED:	Maximum illumination at $\pm 10V$ + = red - = green
Iv LED:	Maximum illumination at $\pm 5 mA \setminus \pm 100mA$ + = red - = green
Filter type:	Passive, single pole

Valve filter corner frequency selections:	7, 16, 34, 72 & 723 Hz $\pm 10\%$
Probe filter corner frequency:	154Hz $\pm 10\%$
Class of protection:	IP 20
Supply:	24 V nominal, 22 to 28 V 50 mA @ 24 V, no load
Mounting:	DIN rail
Temperature:	0 to 40°C
Dimensions:	100W x 108H x 22.5D
Weight:	120g
CE mark:	EN50081.1 emission EN50082.2 immunity
C tick:	AS4251.1 emission

Operating Details

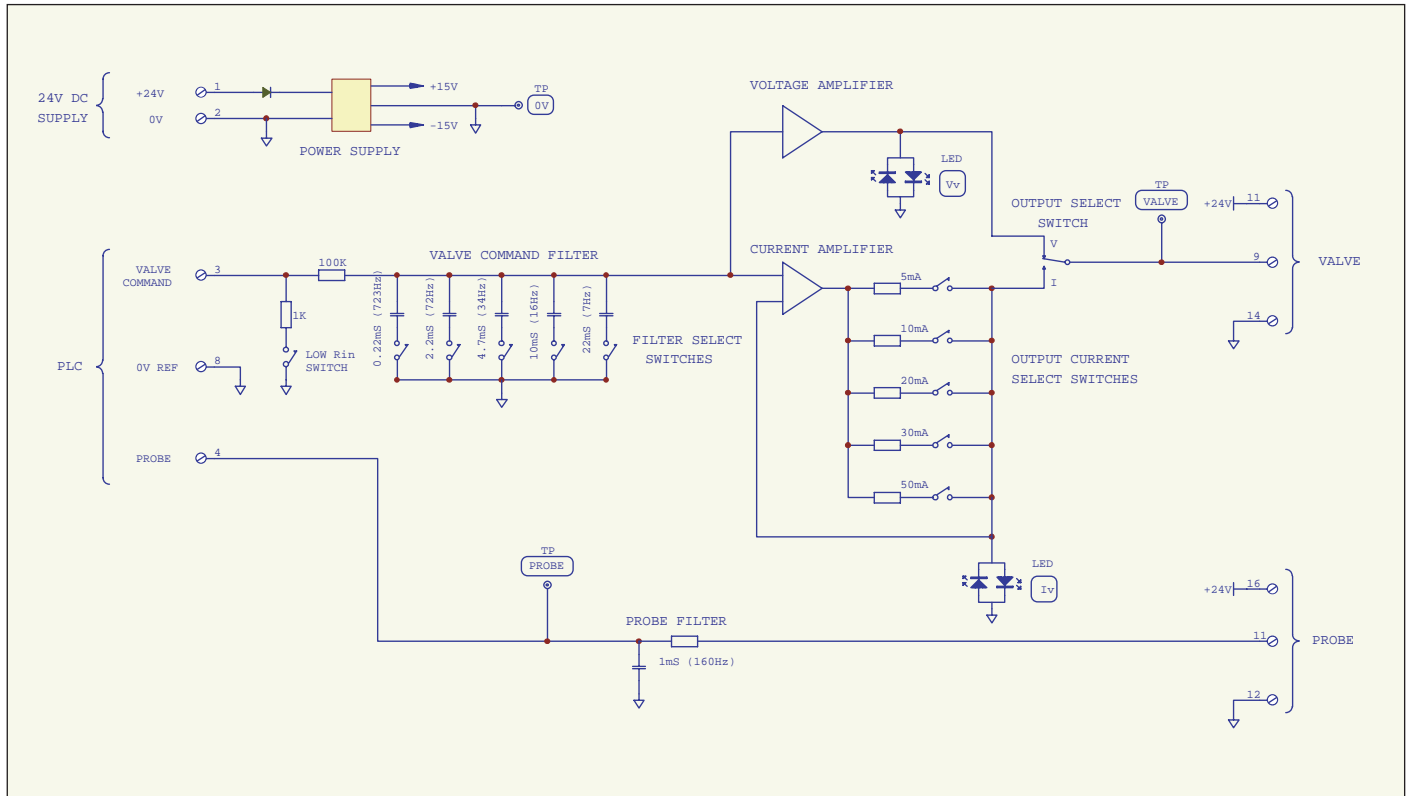

Ordering Information

Buffer Amplifier G123-815-001

Special configurations can be provided.

Consult your Moog sales office to discuss details.



Moog Australia Pty. Ltd. A.C.N. 005 599 584, 14 Miles Street, Mulgrave, Vic 3170. Telephone: + 61 3 9561 6044. Fax: + 61 3 9562 0246.

Moog Australia Pty. Ltd. pursues a policy of continuous development and reserves the right to alter designs and specifications without prior notice. Information contained herein is for guidance only and does not form part of a contract.
 Australia: Melbourne and Sydney ■ Austria: Vienna ■ Brazil: São Paulo ■ Denmark: Birkerød ■ England: Tewkesbury ■ Finland: Espoo ■ France: Rungis ■ Germany: Böblingen, Dusseldorf ■ Hong Kong: Shatin ■ India: Bangalore
 Ireland: Ringaskiddy ■ Italy: Malnate (VA) ■ Japan: Hiratsuka ■ Korea: Kwangju-Kun ■ Philippines: Baguio City ■ Singapore: Singapore ■ Sweden: Askim ■ USA: East Aurora (NY)