

Tomador de pressão SKK (para montagem com porca e anel conforme DIN 2353) - Tubulação métrica

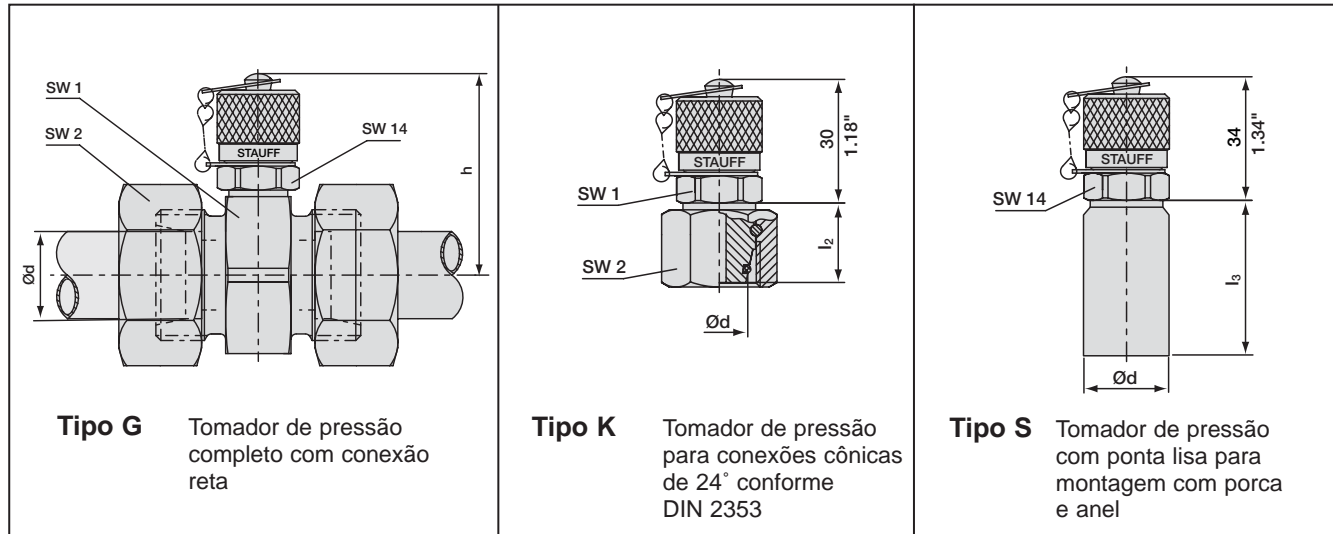

Série	PN	Tubo Ød	l ₂		l ₃		h		SW 1		SW 2		Código para Pedido*		
			mm	pol	mm	pol	mm	pol	mm	pol	mm	pol	Tipo G	Tipo K	Tipo S
L	315	6	15,5	0.61	20	0.79	46	1.81	24	0.94	14	0.55	SKK 12 - 6L-VG	SKK 12 - 6L-VK	SKK 12 - 6-VS
		8	15,5	0.61	20	0.79	46	1.81	24	0.94	17	0.67	SKK 12 - 8L-VG	SKK 12 - 8L-VK	SKK 12 - 8-VS
		10	16,5	0.65	22	0.87	46	1.81	24	0.94	19	0.75	SKK 12 - 10L-VG	SKK 12 - 10L-VK	SKK 12 - 10-VS
		12	17,5	0.69	22	0.87	47,5	1.87	27	1.06	22	0.87	SKK 12 - 12L-VG	SKK 12 - 12L-VK	SKK 12 - 12-VS
		15	21	0.83	25	0.98	49	1.93	30	1.18	27	1.06	SKK 12 - 15L-VG	SKK 12 - 15L-VK	SKK 12 - 15-VS
		18	19,5	0.77	28	1.10	50	1.97	32	1.26	32	1.26	SKK 12 - 18L-VG	SKK 12 - 18L-VK	SKK 12 - 18-VS
	160	22	20,5	0.81	30	1.18	52	2.05	36	1.42	36	1.42	SKK 12 - 22L-VG	SKK 12 - 22L-VK	SKK 12 - 22-VS
		28	25	0.98	32	1.26	54,5	2.15	41	1.61	41	1.61	SKK 12 - 28L-VG	SKK 12 - 28L-VK	SKK 12 - 28-VS
		35	30	1.18	42	1.65	57	2.24	46	1.81	50	1.97	SKK 12 - 35L-VG	SKK 12 - 35L-VK	SKK 12 - 35-VS
		42	31	1.22	45	1.77	61,5	2.42	55	2.17	60	2.36	SKK 12 - 42L-VG	SKK 12 - 42L-VK	SKK 12 - 42-VS
S	630	6	14,5	0.57	20	0.79	46	1.81	24	0.94	17	0.67	SKK 12 - 6S-VG	SKK 12 - 6S-VK	SKK 12 - 6-VS
		8	16,5	0.65	20	0.79	46	1.81	24	0.94	19	0.75	SKK 12 - 8S-VG	SKK 12 - 8S-VK	SKK 12 - 8-VS
		10	16,5	0.65	22	0.87	46	1.81	24	0.94	22	0.87	SKK 12 - 10S-VG	SKK 12 - 10S-VK	SKK 12 - 10-VS
		12	17,5	0.69	22	0.87	46	1.81	24	0.94	24	0.94	SKK 12 - 12S-VG	SKK 12 - 12S-VK	SKK 12 - 12-VS
		14	19,5	0.77	22	0.87	47,5	1.87	27	1.06	27	1.06	SKK 12 - 14S-VG	SKK 12 - 14S-VK	SKK 12 - 14-VS
	400	16	18	0.71	28	1.10	49	1.93	30	1.18	30	1.18	SKK 12 - 16S-VG	SKK 12 - 16S-VK	SKK 12 - 16-VS
		20	24	0.94	30	1.18	52	2.05	36	1.42	36	1.42	SKK 12 - 20S-VG	SKK 12 - 20S-VK	SKK 12 - 20-VS
		25	26	1.02	36	1.42	54,5	2.15	41	1.61	46	1.81	SKK 12 - 25S-VG	SKK 12 - 25S-VK	SKK 12 - 25-VS
		30	30	1.18	41	1.61	57	2.24	46	1.81	50	1.97	SKK 12 - 30S-VG	SKK 12 - 30S-VK	SKK 12 - 30-VS
		315	38	1.34	48	1.89	61,5	2.42	55	2.17	60	2.36	SKK 12 - 38S-VG	SKK 12 - 38S-VK	SKK 12 - 38-VS

* Para as vedações EPDM substitua "V" por "E"