

Steering Angle Sensor Absolute: SASA

STEERING WHEEL POSITION

The SASA sensor detects the absolute position and speed of the steering wheel. The sensor can be used in electro-hydraulic steering systems using Sauer-Danfoss EH or EHPS steering valves with programmable controller.

The use of SASA sensor is relevant e.g. for variable steering ratio and closed loop set-ups where steering wheel position and steering angle have to match.

SASA is based on a noncontact inductive principle giving a very high resolution. The sensor features a robust design and resist e.g. electro-magnetic radiation. The output is a CAN signal, which makes it easy to interface to advanced vehicle controllers.

The steering wheel shaft turns the rotor of the SASA sensor, and the sensor is simply mounted between steering unit and steering column.

The new SASA sensor offers the following features:



F301379

150201

Features:

- High resolution $<0,1^\circ$
- Output CAN signal
- High safety, "fail silent" concept
- Flanged in between steering unit and column
- Compact design

TECHNICAL DATA

Steering wheel sensor SASA is used in different applications: Agriculture, Construction, Road building etc.

Supply voltage	9 - 32 V _{DC}
Mechanical input range	Continuous 360° rotation
Output	CAN V2.0B passive (compatible to J1939) Baurate: 125, 250 or 500 kb/s Angle: 12-bit word (0 - 4095) relative to a programmable 0-index point.
Resolution	<0,1°
Linearity	±1.0%
Safety function	If a failure occurs the CAN-bus will "fail silent" (The CAN-bus driver will be disabled).
Temperature range	-30° to 85°C [-22 to 185°F]
Installation	To be mounted between steering column and steering unit (OSP) with 4 bolts max 30 N·m [265.5 lbf·in]. Shaft in column must be 15 mm [0.59 in] longer. For use of original steering column, use adapter kit type SAK, see sketch below. Electric connection through cable mounted with an AMP Connector.

DIMENSIONS SASA

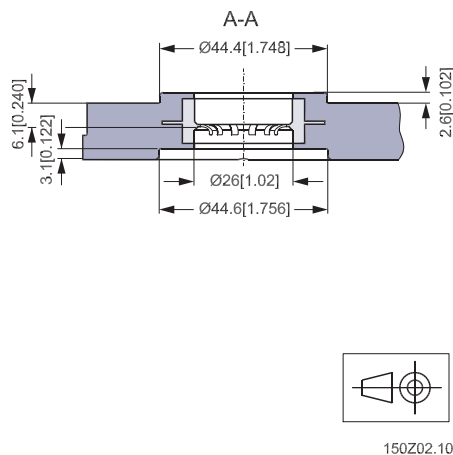
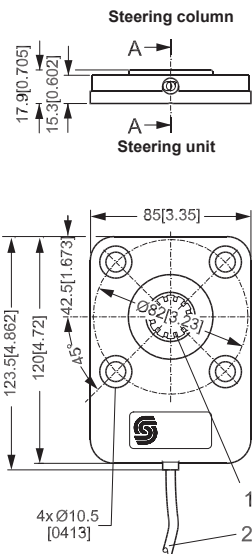

SAK

SAK adapter kit on SASA sensor and on OSP steering unit

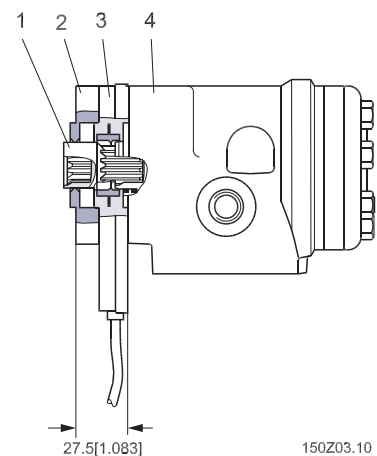

1. Flexible teeth, 12 pieces to interact with splines on steering column
2. Cable, 500 mm with AMP connector type 2-967059-1

1. Shaft of SAK adapter kit
2. Distance plate of SAK adapter kit
3. SASA sensor
4. OSP steering unit