

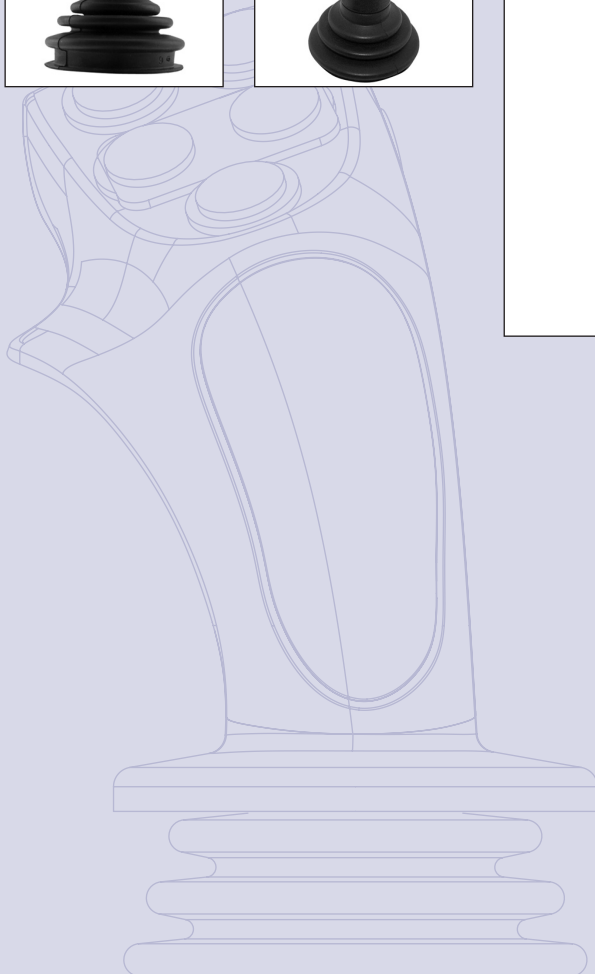

# JS1000, JS6000 Joystick Grips

## Technical Information



COMPLIANT



**Revisions***Revisions*

Date	Page	Changed	Rev.
02 Sep, 2008	Cover	obsolete joystick removed, replaced with ball grip	EA
04 Jan, 2008	Various	Content update	DA
06 Dec, 2005	9	Operating and storage temperature updated	C

© 2008, Sauer-Danfoss. All rights reserved. Printed in U.S.A.

Sauer-Danfoss accepts no responsibility for possible errors in catalogs, brochures and other printed material. Sauer-Danfoss reserves the right to alter its products without prior notice. This also applies to products already ordered provided that such alterations can be made without affecting agreed specifications. All trademarks in this material are properties of their respective owners. Sauer-Danfoss, the Sauer-Danfoss logotype, the Sauer-Danfoss S-icon, PLUS+1™, what really matters is inside® and Know-How in Motion™ are trademarks of the Sauer-Danfoss Group.

Front cover illustrations: 2243, F005 200, F101 448, 2238, F101 431, 2254.

**General Information**

Introduction ..... 5  
 JS1000, JS6000 Grip Selection Guide..... 5  
     Grip Options and Joystick Base Compatibility ..... 5  
     Product Configuration Model Code..... 6

**JS1000 Grips**

JS1000 Grip Product Configuration Model Code..... 7  
 PRO Grip ..... 10  
     Product Overview ..... 10  
     Model Code Nomenclature ..... 10  
     Specifications ..... 10  
     Connector Pin Assignments..... 11  
     Front Plate Model Code Designations..... 12  
     Dimensions ..... 13  
 Grip with Rocker Switch/Grip with Banana Switch ..... 14  
     Product Overview ..... 14  
     Model Code Nomenclature ..... 14  
     Specifications ..... 14  
 Grip with Rocker Switch ..... 15  
     Connector Pin Assignments..... 15  
     Dimensions ..... 15  
 Grip with Banana Switch ..... 16  
     Dimensions ..... 16  
 Ball Grip..... 17  
     Product Overview ..... 17  
     Model Code Nomenclature ..... 17  
     Specifications ..... 17  
     Connector Pin Assignments..... 17  
 Dimensions..... 18

**JS6000 Grips**

JS6000 Grip Product Configuration Model Code..... 19  
 JS6000 Grip Function Connector Pin ..... 22  
     JS6000 Grip Function Connector Pin Assignments ..... 22  
 A Grip ..... 23  
     Product Overview ..... 23  
     Model Code Nomenclature ..... 23  
     Front Plate Model Code Designations..... 25  
     Rocker Switch Profiles ..... 25  
     Rocker Switch Specifications ..... 26  
     Rocker Switch Wiring Details ..... 27  
     Push Button Specifications..... 28  
     Push Button Wiring Details..... 28  
     Connector Pin Assignments..... 29  
     Dimensions ..... 32  
 MG Grip ..... 33  
     Product overview..... 33  
     Model Code Nomenclature ..... 34  
     Specifications ..... 34  
     Connector Pin Assignments..... 35  
     Switch Wiring Details..... 36  
     Dimensions ..... 36



JS1000, JS6000 Joystick Grips  
Technical Information  
Contents

**JS6000 Grips  
(continued)**

HKN Grip .....37  
Product Overview .....37  
Model Code Nomenclature.....37  
Specifications .....37  
Dimensions .....37

**Grip and Joystick Base  
Service Parts**

Service Part Information .....38

**Introduction**

Sauer-Danfoss joysticks offer mobile machine product engineers a wide array of grip designs. Each of the grip designs outlined in this document meets the demanding conditions typically found in mobile equipment environments.

The many available grip features provide OEM engineers with options offering a high degree of protection from chemicals, high-pressure wash, shock, vibration and EMC exposure. Sauer-Danfoss grips are appropriate for both in-cabin and out of cabin applications and feature ergonomic forms that minimize machine operator fatigue.

This publication provides technical information required to specify the grip portion of JS1000 and JS6000 joysticks. Sauer-Danfoss *JS1000 Joystick Base Technical Information* manual **520L0826** and *JS6000 Joystick Base Technical Information* manual **520L0760** provide technical information required to specify joystick bases.

**JS1000, JS6000  
 Grip Selection Guide**







**Grip Options and Joystick Base Compatibility**

Use the following table to determine which joystick base mates with specific Sauer-Danfoss joystick grips.

*JS1000, JS6000 Grip Options and Joystick Base Compatibility*

Grip designation	Compatible with		Grip functionality (maximum number)				Operator presence
	JS1000 base	JS6000 base	Momentary switches	Proportional inputs			
				Rocker	Banana	Roller	
PRO	X		X (6)			X (2)	
Grip with Rocker Switch	X			X (1)			
Grip with Banana Switch	X				X (1)		
Ball	X						
A		X	X (8)	X (2)			X (1)
MG		X	X (2)				X (1)
HKN		X					

*JS1000, JS6000 Joystick Grips*

<b>PRO grip</b> see pages 10 – 13 	<b>Grip with rocker switch/            Grip with banana switch</b> see pages 14 – 16 	<b>Ball grip</b> see pages 17– 18 
<b>A grip</b> see pages 23 – 32 	<b>MG grip</b> see pages 33 – 36 	<b>HKN grip</b> see page 37 

**JS1000, JS6000  
Grip Selection Guide  
(continued)**

**Product Configuration Model Code**

A product configuration model code (model code) is used to specify particular features when ordering JS1000 or JS6000 joysticks. The model code begins with the product family name and the remaining fields are filled in to configure the product with the desired features.

JS1000 and JS6000 model codes contain information relating to both base features and grip features.

JS1000 Grip  
 Product Configuration  
 Model Code

JS1000 grip product configuration model code example – base part - A, B, C, D and E1

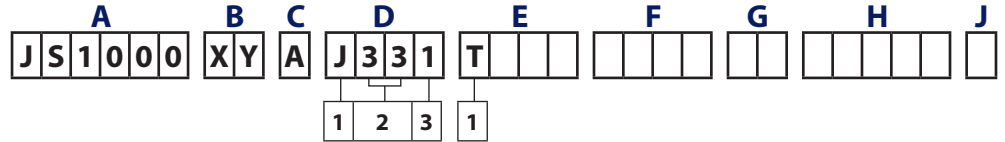

**A** Product Family

Code	Description
JS1000	JS1000 joystick base with Deutsch® connector, spring return to center

**B** Single or Dual Axis

Code	Description
XY	Dual axis function, forward and reverse with left and right, with guided axis (force is increased in the corners)
NY	Single axis function, forward and reverse
NG	Dual axis function, without guided axis feel (free moving in all directions)

**C** Center Return Spring

Code	Description
A	Standard spring
B	Heavy spring

**D1** Electrical Interface Options

Code	Description
J	CAN with J1939 message protocol
S	Analog voltage output

**D2** Joystick CAN Source Address

Code	Description
NN	None—use with analog output (when D1=S)
33	Source address = 33 (hex)
34	Source address = 34 (hex)
35	Source address = 35 (hex)
36	Source address = 36 (hex)

**D3** Joystick Output Type

Code	Description
N	None—use with analog output (when D1=S)
1	CAN full scale output = 1000 counts

**E1** Grip Mounting Options

Code	Description
B	Bottom mount (from below the panel, no boot retainer included, boot is captured between panel and housing) <b>with vent plug*</b>
C	Bottom mount (from below the panel, no boot retainer included, boot is captured between panel and housing) <b>without vent plug*</b>
T	Top mount (from above the panel, includes boot retainer for attaching boot to joystick housing) <b>with vent plug*</b>
U	Top mount (from above the panel, includes boot retainer for attaching boot to joystick housing) <b>without vent plug*</b>

\* Vent plug is a Gore-Tex® moisture barrier. If the plug is not present, Ingress Protection below the base is unrated.

PRO grip option top mount only.

**JS1000 Grip  
 Product Configuration  
 Model Code  
 (continued)**

*JS1000 grip product configuration model code example – joystick part - E2 and F*

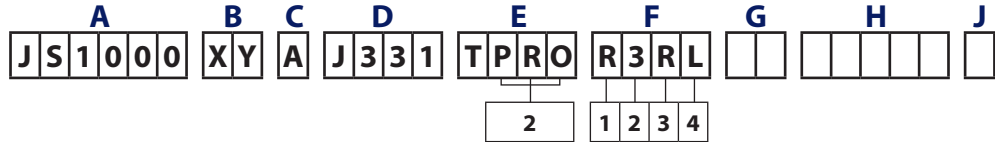

**E2** *Grip Mounting and Handle Options*

Code	Description
<b>PRO</b>	PRO grip, CAN output. <b>Complete section F, G, H, J</b>
<b>PR1</b>	PRO grip, with no switch or proportional functions, CAN output.
<b>K01</b>	Ball grip <b>Do not complete F, G, H, J</b>
<b>LSW</b>	Grip with analog rocker switch, 1.15 to 3.75 V DC range. <b>Do not complete F, G, H, J</b>
<b>LSB</b>	Grip with banana switch, 1.15 to 3.75 V DC range. <b>Do not complete F, G, H, J</b>

PRO grip available with CAN option only. Grips with switches available with analog option only.

**F1** *PRO Grip Function Layout*

Code	Description
<b>R...</b>	Right handed grip
<b>L...</b>	Left handed grip

**F3** *PRO Grip Function Layout*

Code	Type of proportional function
<b>..R.</b>	Roller or wheel, not sealed
<b>..N.</b>	None

**F2** *PRO Grip Function Layout*

Code	Number of switches on the front plate
<b>.0..</b>	No switches
<b>.1..</b>	1 switch
<b>.2...</b>	2 switches
<b>.3..</b>	3 switches
<b>.4..</b>	4 switches
<b>.5..</b>	5 switches

**F4** *PRO Grip Function Layout*

Code	Position of proportional function
<b>...N</b>	No proportional function required
<b>...R</b>	Vertical proportional function on the Right-hand side
<b>...L</b>	Vertical proportional function on the Left-hand side
<b>...B</b>	Horizontal proportional function on the Bottom
<b>...D</b>	Vertical proportional functions on both the left and the right-hand sides
<b>...S</b>	Horizontal proportional functions as dual set on the top and the bottom
<b>...T</b>	Horizontal proportional function on top



**JS1000 Grip  
 Product Configuration  
 Model Code  
 (continued)**

JS1000 grip product configuration model code example– **joystick part - F, G, H and J**

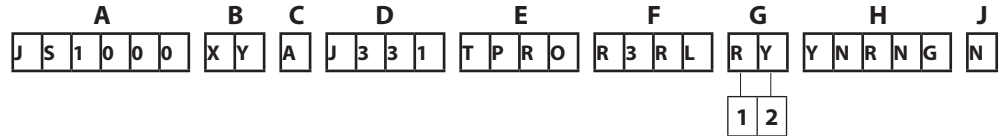

**F Grip Function Layout Examples**

<b>R0NN</b>	Right handed, 0 switches, No roller, No position
<b>R1NN</b>	Right handed, 1 switches, No roller, No position
<b>R2NN</b>	Right handed, 2 switches, No roller, No position
<b>R3NN</b>	Right handed, 3 switches, No roller, No position
<b>R4NN</b>	Right handed, 4 switches, No roller, No position
<b>R5NN</b>	Right handed, 5 switches, No roller, No position
<b>R0RR</b>	Right handed, 0 switches, Roller, Right positioned
<b>R1RR</b>	Right handed, 1 switches, Roller, Right positioned
<b>R2RR</b>	Right handed, 2 switches, Roller, Right positioned
<b>R3RR</b>	Right handed, 3 switches, Roller, Right positioned
<b>R0RL</b>	Right Handed, 0 switches, Roller, Left positioned
<b>R1RL</b>	Right Handed, 1 switches, Roller, Left positioned

<b>R2RL</b>	Right handed, 2 switches, Roller, Left positioned
<b>R3RL</b>	Right handed, 3 switches, Roller, Left positioned
<b>R0RB</b>	Right handed, 0 switches, Roller, Bottom positioned
<b>R1RB</b>	Right handed, 1 switches, Roller, Bottom positioned
<b>R2RB</b>	Right handed, 2 switches, Roller, Bottom positioned
<b>R3RT</b>	Right handed, 3 switches, Roller, Top positioned
<b>R0RD</b>	Right handed, 0 switches, 2 Roller, Dual positioned
<b>R1RD</b>	Right handed, 1 switches, 2 Roller, Dual positioned
<b>R0RS</b>	Right handed, 0 switches, 2 Roller, Stacked positioned
<b>R1RS</b>	Right handed, 1 switches, 2 Roller, Stacked positioned
<b>R2NR</b>	Right handed, 2 switches, No roller, Right positioned
<b>R2NL</b>	Right handed, 2 switches, No roller, Left positioned

**G1 PRO Grip Side Switch Orientation**

Code	Description
<b>R.</b>	Right handed PRO Grip
<b>L.</b>	Left handed PRO Grip

**G2 PRO Grip Side Switch Color**

Code	Description
<b>.R</b>	Red side switch
<b>.Y</b>	Yellow side switch
<b>.B</b>	Black side switch
<b>.G</b>	Grey side switch
<b>.N</b>	No side switch

**H PRO Grip Front Plate Switch Color Selection Examples**

Code	Description
<b>NNNNN</b>	No switches (diagram 0NN*)
<b>RYBGR</b>	Position 1 switch Red, position 2 switch Yellow, position 3 switch Black, position 4 switch Grey, position 5 switch Red (diagram 5NN*)
<b>YYYYY</b>	5 Yellow switches (diagram 5NN*)
<b>RNNRB</b>	Position 1 switch Red, No position 2 switch, No position 3 switch, position 4 switch Red, position 5 switch Black (diagram 3NN*)
<b>YRNNN</b>	Position 1 switch Yellow, Position 2 switch Red, No position 3 switch, No position 4 switch, No position 5 switch (diagram 2RL*)

\* See *PRO Grip front panel diagram*, page 10. Number refers to button location on grip front panel. Select one color code for each switch specified.

**J Operator Presence Switch Option Not Available**

Code	Description
<b>N</b>	No: operator presence switch option not selected

**PRO Grip**



*PRO Joystick Grip*

**Product Overview**

The PRO grip is a patented ergonomic joystick grip that is designed to minimize operator fatigue in operations requiring repetitive, precision movement over extended periods of time. The grip is available in right and left hand versions. The profile of the PRO grip ensures that the operators fingers are close to input functions thus maximizing functional control. The hand rest at the base of the grip and *soft feel elastomeric palm insert* contributes to a comfortable feel and provides additional protection for the joystick boot.

A unique feature of the grip is the intelligent embedded electronics that allows joystick input information to be multiplexed into a two-wire serial signal communicating with base electronics. The intelligent electronics facilitate the compact design of the grip by eliminating the need to pass large numbers of discrete wires through the joystick shaft.

The PRO grip is available with a maximum of six switch inputs or two proportional inputs, or a mix of switch and proportional inputs.

**Model Code Nomenclature**

Grip and grip options are specified using the Sauer-Danfoss joystick model code. For grips designed to mate with the JS1000 joystick base, use code positions E2, F, G and J to specify grip properties. Reference *JS1000 Grip Product Configuration Model Code*, pages 7 to 9.

---

The PRO grip uses all portions of the model code. Other JS1000 grips use only the E2 portion of the model code.

---

**Specifications**

PRO grip switches and proportional rollers are internally wired to a microcontroller located in grip. Grip information is included in joystick base CAN messages.

*Electrical Specifications*

Description	Specification
Switch action	Momentary
Switch type	Single pole, NO
Switch mechanical life	1 million cycles

*Environmental Specifications*

Description	Specification
Operating temperature	-40°C to +85°C [-40°F to +185°F]
Storage temperature	-40°C to +85°C [-40°F to +185°F]
Environmental sealing (without proportional roller)	IP 66, 67

**PRO Grip  
 (continued)**

**Specifications (continued)**

*Proportional Roller Specifications*

Description	Specification
Roller action	Spring return to center
Roller electrical output	±1000 counts from null
Roller mechanical life	5 million cycles
Environmental sealing	IP 43

---

Proportional rollers are not to be used in no cabin or open cabin joystick applications.

---

**Connector Pin Assignments**

PRO grips mounted on JS1000 joystick bases that have user inputs—switches, proportional inputs or a mix of both—must use the CAN electrical output option to transmit grip switch and proportional function information. Refer to the *JS1000 Joystick Base Technical Information* manual **520L0826** for grip CAN message details and connector pin assignments.

**PRO Grip  
 (continued)**

**Front Plate Model Code Designations**

*PRO Grip Front Plate Diagram*

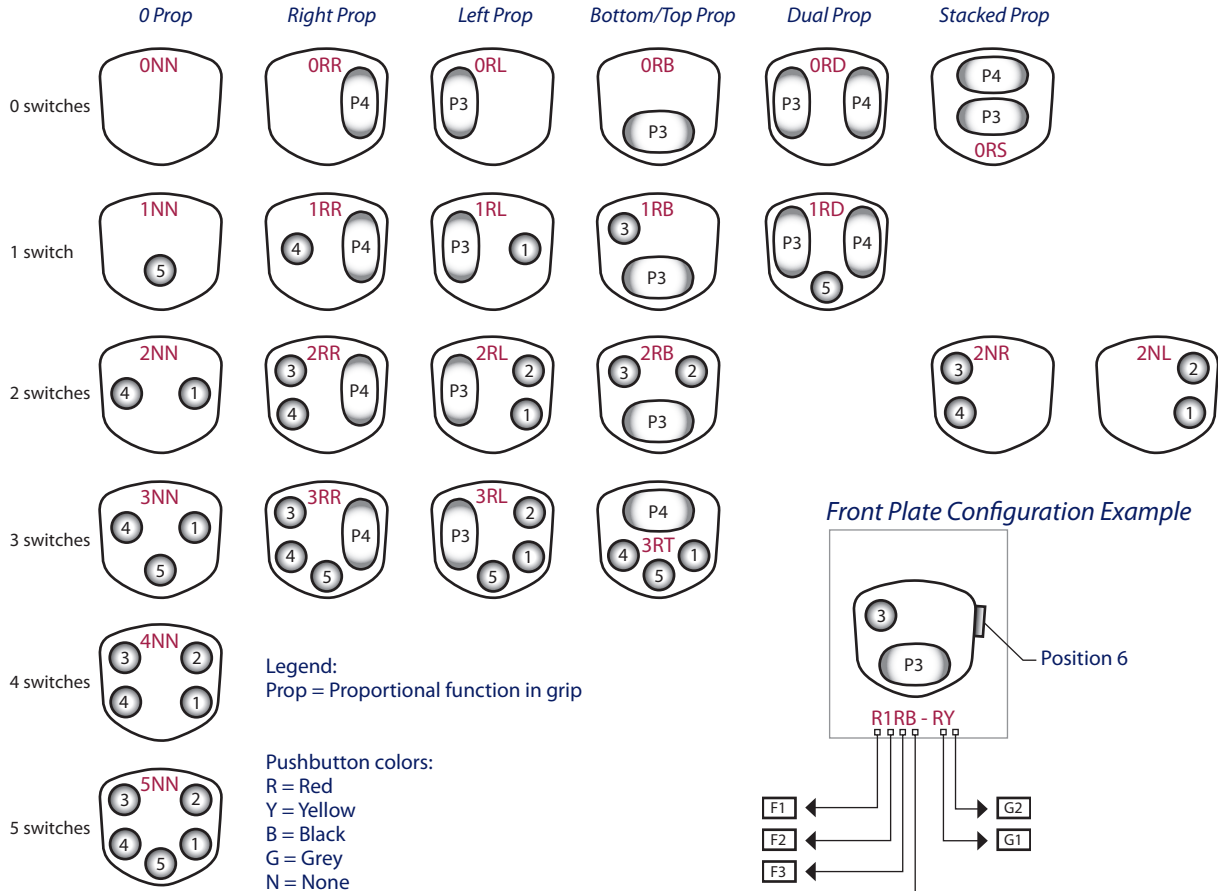

P005301E

**PRO Grip  
 (continued)**

**Dimensions**

*Pro grip dimensions in millimeters [inches].*

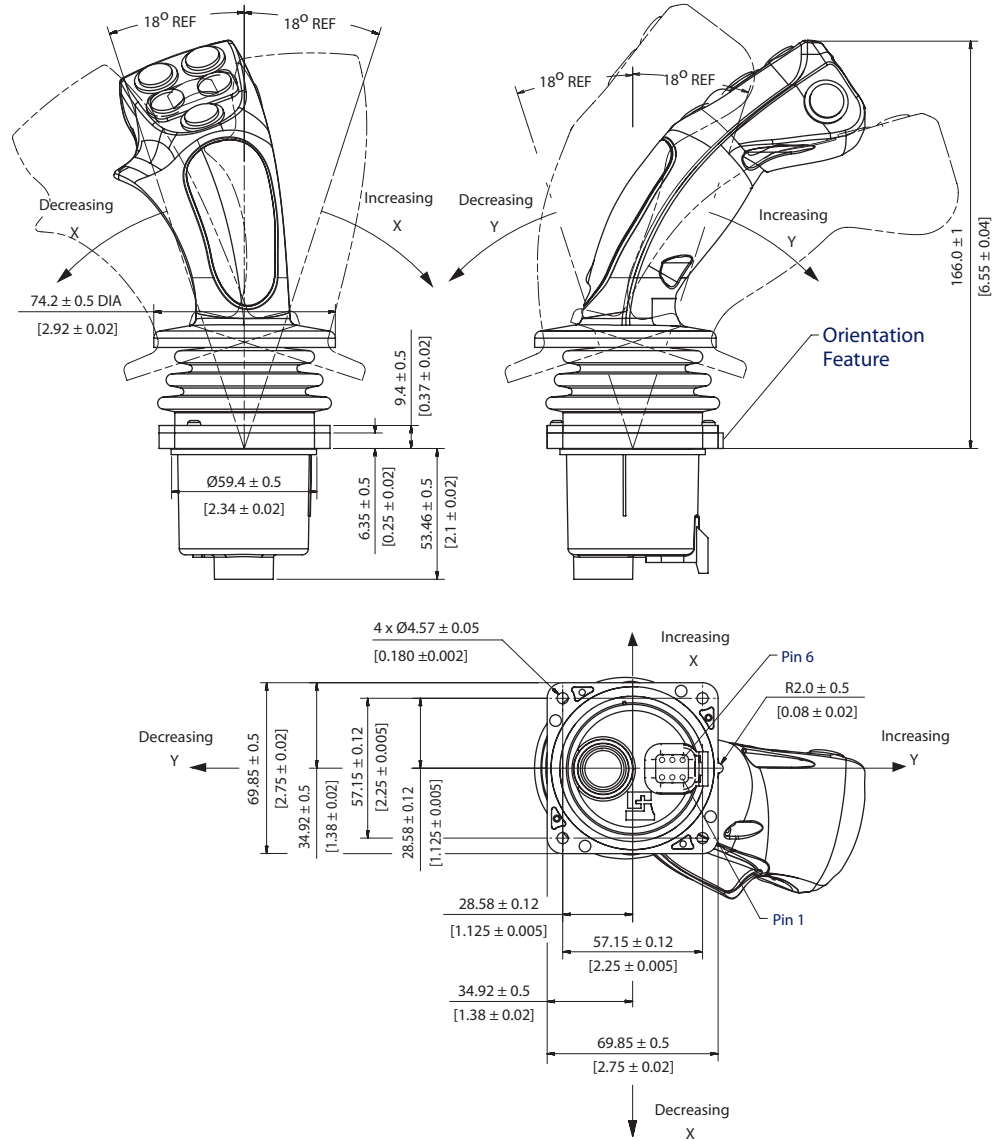

P005 244E

**Grip with Rocker Switch/  
 Grip with Banana Switch**



*Grip with Rocker Switch*



*Grip with Banana Switch*

**Product Overview**

JS1000 grips with switches are intended to provide a simple, flexible and comfortable operator control that includes a proportional input device at the top of the grip. Two shapes are available for the proportional input device: *V rocker* or *banana rocker*. Both grips use Hall sensing technology to detect rocker switch position.

The proportional input generates a nominal 0 to 5 Vdc signal that is used as a change of state (switch) input.

**Model Code Nomenclature**

Grip and grip options are specified using the Sauer-Danfoss joystick model code. For grips designed to mate with the JS1000 joystick base, use code positions E2, F, G and J to specify grip properties. Reference *JS1000 Grip Product Configuration Model Code*, pages 7 to 9.

---

The grip with rocker switch and grip with banana switch are designated using only the E2 portion of the code.

---

**Specifications**

*Top Switch Electrical Specifications*

Description	Specification
Supply voltage	5.0 ± 0.5 Vdc
Maximum survival voltage	18 Vdc Continuous
Maximum current draw	10 mA
Output at maximum displacement	75% ± 8% of supply voltage
Output at null	50% ± 4% of supply voltage
Output at minimum displacement	23% ± 8% of supply voltage

*Top Switch Environmental Specifications*

Description	Specification
Operating temperature	-40°C to +80°C [-40°F to +175°F]
Storage temperature	-40°C to +85°C [-40°F to +180°F]
EMI/RFI rating	100 V/m
Mechanical life	6 million cycles

**Grip with Rocker Switch**

**Connector Pin Assignments**

Both grip-with-switch options may use either the JS1000 base analog or CAN output option. Refer to the *JS1000 Joystick Base Technical Information* manual **520L0826** for grip CAN message details and connector pin assignments.

**Dimensions**

*Grip with rocker switch dimensions in millimeters [inches].*

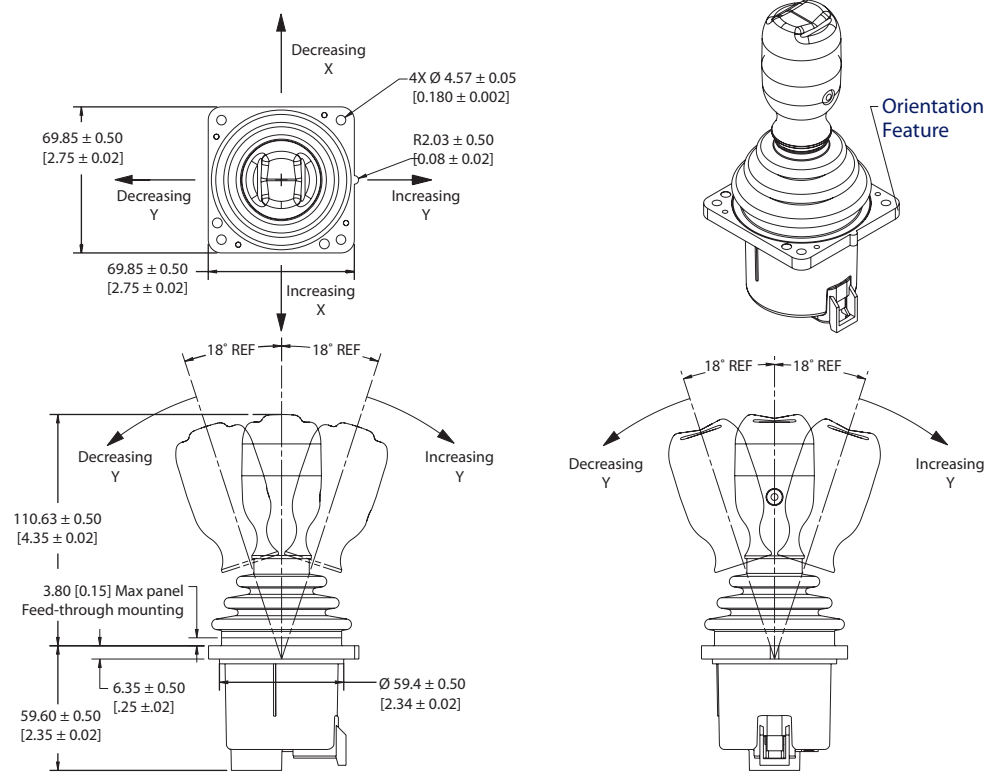

2234A

**Grip with Banana Switch**      **Dimensions**

*Grip with banana switch dimensions in millimeters [inches].*

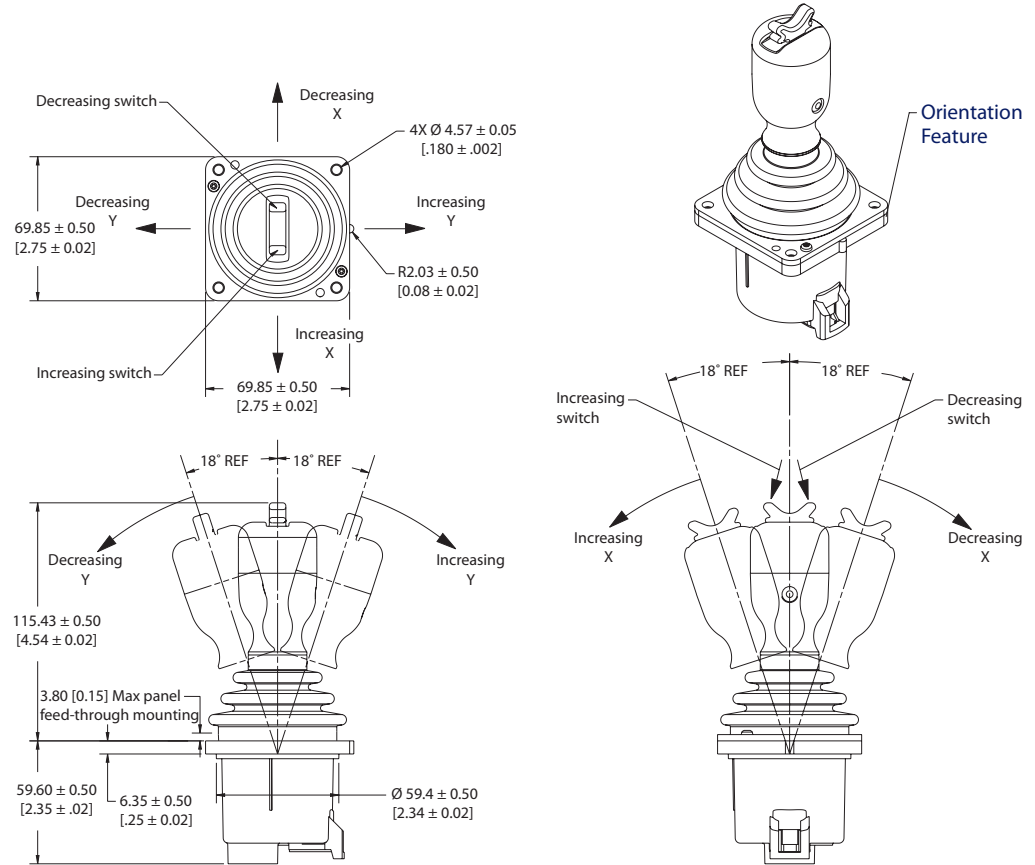

2235A



**Ball Grip**

*Ball Joystick Grip*



**Product Overview**

The JS1000 Ball grip provides a simple and comfortable operator control. Manufactured of high impact plastic, the grip is perfectly suited for mobile machine applications requiring only X-Y control and no switch or proportional input options.

**Model Code Nomenclature**

Grip and grip options are specified using the Sauer-Danfoss joystick model code. For grips designed to mate with the JS1000 joystick base, use code positions E2, F, G and J to specify grip properties. Reference *JS1000 Product Configuration Model Code*, pages 7 to 9.

---

The ball grip is designated using only the E2 portion of the code.

---

**Specifications**

*Environmental Specifications*

Description	Specification
Operating temperature	-40°C to + 80°C [-40°F to +175°F]
Storage temperature	-40°C to + 85°C [-40°F to +180°F]
Environmental protection	IP 66, 67

**Connector Pin Assignments**

The ball grip has no electrical outputs. It can be mounted on JS1000 bases having either a CAN or analog output. Refer to the *JS1000 Joystick Base Technical Information* manual **520L0826** for grip CAN message details and connector pin assignments.

**Ball Grip  
 (continued)**

**Dimensions**

Ball grip dimensions in millimeters [inches].

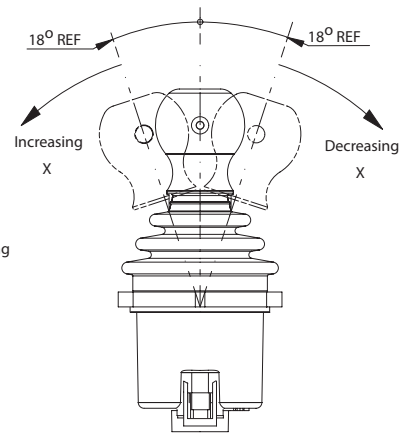
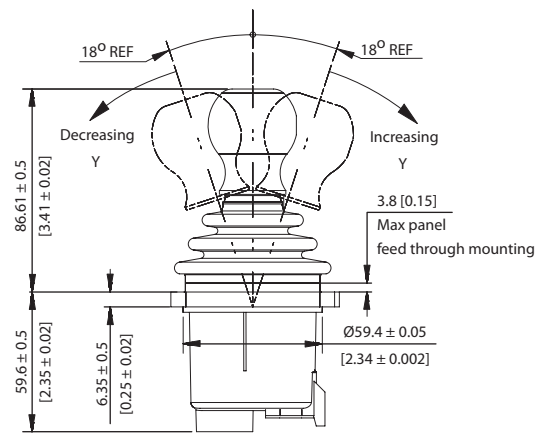
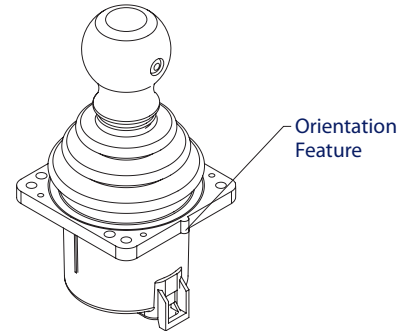
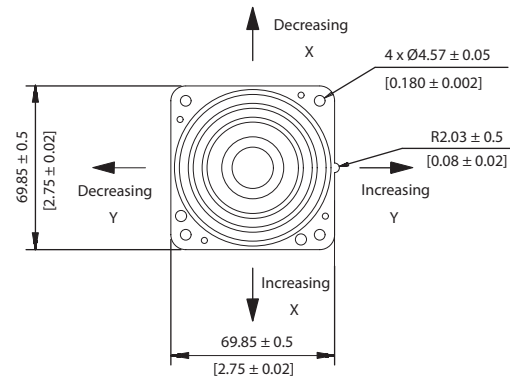

P005 243E

**JS6000 Grip  
 Product Configuration  
 Model Code**

JS6000 product configuration model code example – **base part - A, B, C, D, E, F and G**

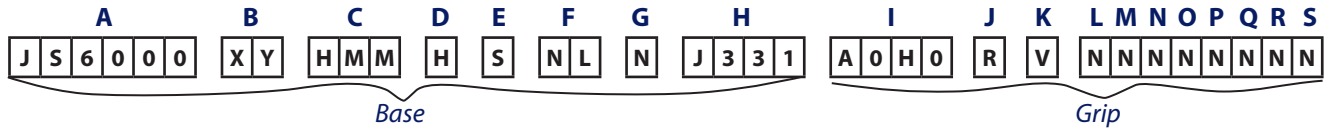

**A Product Series**

Code	Description
JS6000	Series JS6000 Joystick

**B Operational Axis Options**

Code	Description
XY	Bi-directional: X and Y axis
NY	Uni-directional: Y axis only (required for friction-holding)

**C Shaft Position Sensing and Output Options**

Code	Description
PRR	Potentiometer: single output per axis; $V_o = 10$ to 90% of $V_s$ ; $\pm 1.5^\circ$ neutral threshold
PQQ	Potentiometer: single output per axis; $V_o = 25$ to 75% of $V_s$ ; $\pm 1.5^\circ$ neutral threshold
PSS	Potentiometer: single output per axis; $V_o = 10$ to 90% of $V_s$ ; $\pm 5^\circ$ neutral threshold
PTT	Potentiometer: single output per axis; $V_o = 25$ to 75% of $V_s$ ; $\pm 5^\circ$ neutral threshold
PUU	Potentiometer: dual output per axis; $V_o = 10$ to 90% of $V_s$ ; $\pm 1.5^\circ$ neutral threshold
HMM	Hall effect: dual sensors per axis; $V_s = 5 V_{DC}$ ; $V_o = 0.5$ to $4.5 V_{DC}$
CAN	Hall effect: dual sensors per axis; $V_s = 9$ to $36 V_{DC}$ ; CAN 2.0B communication, 6 pin connector
CPL	Hall effect: dual sensors per axis; $V_s = 9$ to $36 V_{DC}$ ; CAN 2.0B communication, 18 pin connector

**D Centering Spring Options**

Code	Description
H	Heavy force
M	Medium force
L	Light force
F	Friction-hold (position maintained, center detent)

**E Gate Pattern Options**

Code	Description
S	Square, full output at 45 degree

**F Mechanical Options**

Code	Description
NL	No mechanical option; spring return to center only
FB	Friction-held in Y axis; no X axis; center detent; 1.25 N·m [0.92 lb·ft] friction-hold force; 2.5 N·m [1.66 lb·ft] breakout force
FC	Friction-held in Y axis; no X axis; center detent; 1.25 N·m [0.92 lb·ft] friction-hold force; 3.25 N·m [2.40 lb·ft] breakout force
HC	Friction-held in Y axis; no X axis; center detent; 2.25 N·m [1.66 lb·ft] friction-hold force; 4.0 N·m [2.95 lb·ft] breakout force

**G Direction (Microswitch) Options**

Code	Description
N	No switches
Y	Microswitches installed (analog potentiometer option only)

**JS6000 Grip  
 Product Configuration  
 Model Code  
 (continued)**

JS6000 grip product configuration model code example – **grip properties - I, J, K, L, M, N, O, P, Q, R, and S**

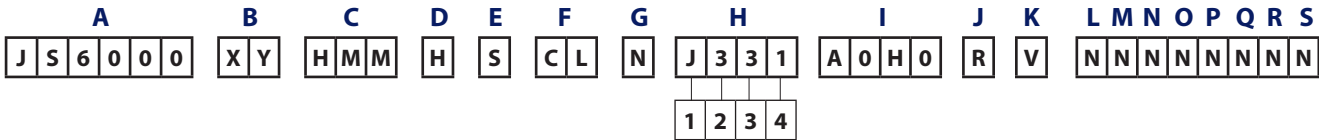

**H1 Electrical Interface Options**

Code	Description
S	Analog (voltage output from joystick sensors or switches)
J	CAN, SAE J1939 protocol

**H2, 3 CAN Source Address\***

Code	Description
NN	None—use with analog outputs when H1 = S
33	Source address = 0x 33
34	Source address = 0x 34
35	Source address = 0x 35
36	Source address = 0x 36

\* Consult the factory if additional source addresses are required.

**H4 Joystick Output Type**

Code	Description
N	None—use with analog outputs when H1 = S
1	CAN full scale output = 1000 counts

**I, J, K Grips, grip proportional rocker output and style**

For grips designed to mate with the JS6000 joystick base, use code positions, I through S to specify grip properties. Refer to *Front Plate Model Code Designation*, page 25 for rocker switch location examples.

**I Grip switch details**

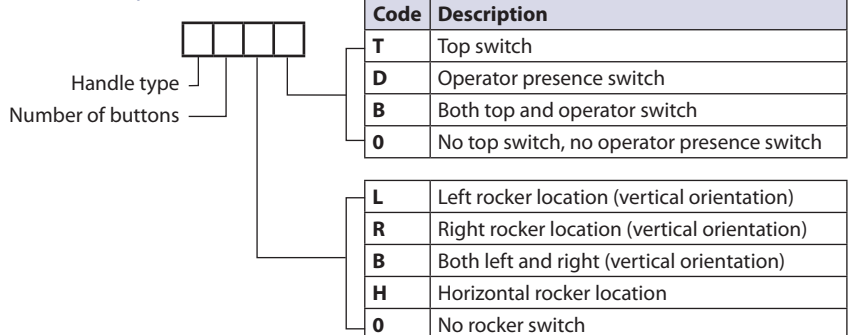

**J A grip proportional rocker output**

Code	Definition
R	Potentiometer, 10% to 90% Vs
Q	Potentiometer, 25% to 75% Vs
N	None

**K A grip proportional rocker style**

Code	Definition
S	Wave style
V	V style
N	None

**JS6000 Grip  
 Product Configuration  
 Model Code  
 (continued)**

**L, M, N, O, P, Q, R, S**      *Grip options*

For A grips use code positions L, M, N, O, P, Q, R, and S to specify grip button colors.

*Grip Button Position to Model Code Conversion*

Grip front plate button position*	Corresponding master model code
1	L
2	M
3	N
4	O
5	P
6	Q
7	R
8	S

See *A Grip Button Position Designations*, pages 29 to 32.

*Grip Button Color Options*

Code	Description
R	Red
B	Black
G	Green
Y	Yellow
L	Blue
N	No push button switch

### JS6000 Grip Function Connector Pin

#### JS6000 Grip Function Connector Pin Assignments

Pin assignments for the JS6000 connector that contains grip outputs are dependent on the type of joystick shaft position sensor (potentiometer or Hall) and the electrical output option (analog or CAN) selected for the joystick base. Analog base grip pin assignments are found on pages 29 to 32 and page 35 of this manual. Pin assignments for other analog base functions are found in the *JS6000 Joystick Base Technical Information* manual **520L0760**.

Grip pin assignments for joystick bases that have analog outputs depend on whether a potentiometer or Hall sensor is used to measure the position of the joystick shaft. If a potentiometer is used, the 12 pin connector on the joystick base is used for grip outputs. If a Hall sensor is used, the 16 pin connector is used for grip outputs.

If the CAN electrical output option is selected, a 6 or 18 pin Deutsch® connector is provided in the base and input information from the grip is broadcast in a J1939 message format. Refer to the *JS6000 Joystick Base Technical Information* manual **520L0760** for details on J1939 CAN grip messages and Deutsch connector pin assignments.

**A Grip**



**Multi-function Grip**

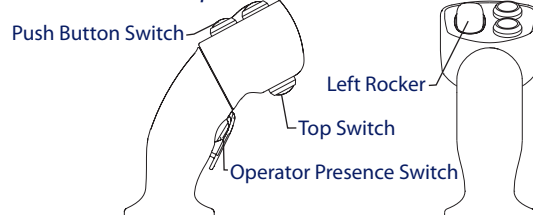

2265

**Product Overview**

The A grip is a multi-function, ambidextrous ergonomic grip designed for a comfortable user interface and maximum functional control. The grip features a modular design that allows switch and proportional rocker location flexibility.

The A grip is available with combinations of up to eight switches and up to two proportional inputs. One of the optional switches can be used to provide an operator presence function on the grip. Available button colors are red, black, green, yellow, and blue.

**Model Code Nomenclature**

Grip and grip options are specified using the Sauer-Danfoss joystick model code. For grips designed to mate with the JS6000 joystick base, use code positions I through S to specify grip properties. Reference *JS6000 Grip Product Configuration Model Code*, pages 19 to 21.

*Model Code for A Grip Front Plate Options*

I Code	Number of momentary switches—grip front plate	Number, location of proportional rocker switches—grip front plate	Number, location of momentary switches—back of grip
A000	0	0	0
A00T	0	0	T
A00D	0	0	D
A00B	0	0	B
A0L0	0	L	0
A0LD	0	L	D
A0R0	0	R	0
A0RD	0	R	D
A0B0	0	B	0
A0BD	0	B	D
A0H0	0	H	0
A0HD	0	H	D
A0RB	0	R	B
A0RT	0	R	T
A0LB	0	L	B
A0LT	0	L	T
A100	1	0	0
A10T	1	0	T
A10D	1	0	D
A10B	1	0	B
A1L0	1	L	0
A1R0	1	R	0
A1H0	1	H	0

**A Grip  
 (continued)**

*Model Code for A Grip Front Plate Options (continued)*

<b>I Code</b>	<b>Number of momentary switches—grip front plate</b>	<b>Number, location of proportional rocker switches—grip front plate</b>	<b>Number, location of momentary switches—back of grip</b>
A1LD	1	L	D
A1RD	1	R	D
A1HD	1	H	D
A1RT	1	R	T
A1LT	1	L	T
A1RB	1	R	B
A1LB	1	L	B
A200	2	0	0
A20T	2	0	T
A20D	2	0	D
A20B	2	0	B
A2L0	2	L	0
A2R0	2	R	0
A2H0	2	H	0
A2LD	2	L	D
A2RD	2	R	D
A2HD	2	H	D
A2RB	2	R	B
A2RT	2	R	T
A2LB	2	L	B
A2LT	2	L	T
A300	3	0	0
A30T	3	0	T
A30D	3	0	D
A30B	3	0	B
A3R0	3	R	0
A3RD	3	R	D
A3L0	3	L	0
A3LD	3	L	D
A3RT	3	R	T
A3LT	3	L	T
A400	4	0	0
A40T	4	0	T
A40D	4	0	D
A40B	4	0	B
A500	5	0	0
A50D	5	0	D
A50B	5	0	B
A50T	5	0	T
A600	6	0	0
A60D	6	0	D
A60B	6	0	B
A60T	6	0	T



**A Grip  
 (continued)**

**Front Plate Model Code Designations**

*A Grip Front Plate Diagram*

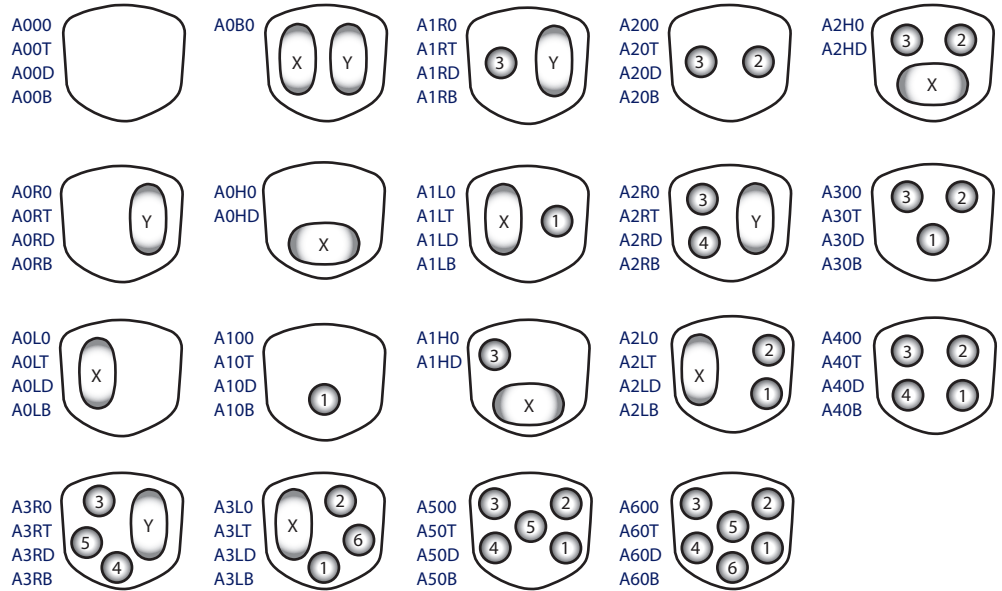

2247A

**Rocker Switch Profiles**

*Profile of Wave Rocker Switch Option*

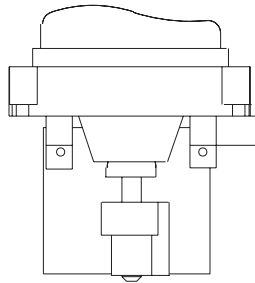

*Profile of V Rocker Switch Option*

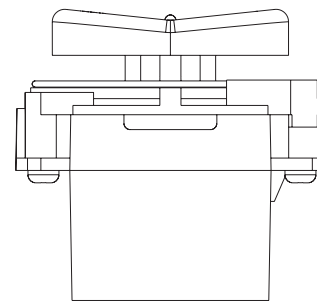

2248

**A Grip  
 (continued)**

**Rocker Switch Specifications**

The optional grip rocker switches use a conductive plastic potentiometer to generate an analog output that is proportional to switch position. The wipers that run across the potentiometer track are driven by the thumb operated rocker mechanism. Rocker switch action is spring return to center.

*Mechanical Specifications*

Description	Specification
Breakout force	5 N [1.12 lbf]
Operating force	15 N [3.37 lbf]
Maximum applied force	50 N [11.24 lbf]
Mechanical angle of movement	± 12°
Electrical angle of movement	± 9°
Expected life	>5 million operations

*Environmental Specifications*

Description	Specification
Operating temperature	-40°C to +70°C [-40°F to +158°F]
Storage temperature	-40°C to +80°C [-40°F to +176°F]
Environmental sealing	IP 65

*Electrical Specifications*

Description	Specification
Maximum load current	Potentiometer wiper* Directional switches: 200 mA
Maximum power dissipation	0.25 W at 25° C [77° F]
Output voltage ranges	25 to 75% Vs 10 to 90% Vs
Center tap voltage	50% Vs ± 2%
Center tap angle	1.5° either side of center
Directional switch operating angle	2.5° either side of center
Directional switch maximum supply voltage	36 Vdc
Directional switch current rating	5 mA

- Center tap has an angle of ± 1.5°
- 50% of the Vs is supplied at the center position
- The track also has a directional switch with a center off switch
- The direction switch changes state after a movement of 2.5° in each direction
- The switch current rating is 5 mA

---

\* The rocker is only to be used as a potentiometer and not as a variable resistor. Wiper load must be resistance greater than 100 kΩ.

---

**A Grip  
 (continued)**

**Rocker Switch Wiring Details**

*Left Rocker*

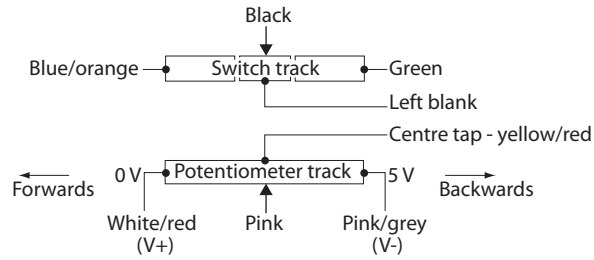

*Right Rocker*

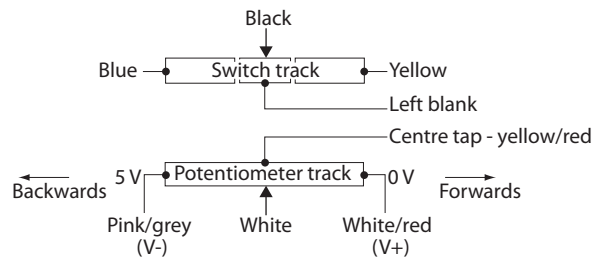

*Horizontal Rocker*

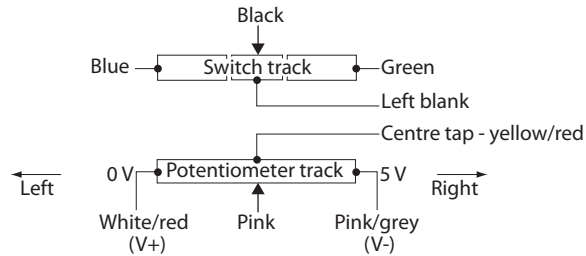

2249

**A Grip  
 (continued)**

**Push Button Specifications**

*Push Button Electrical Specifications*

Description	Specification
Switch action	Momentary
Switch type	Single pole, NO
Contact rating	200 mA at 50 Vdc - person present switch
	100 mA at 50 Vdc - top and front plate switches
Contact resistance	50 MΩ maximum
Mechanical life	1 million cycles

*Push Button Environmental Specifications*

Description	Specification
Operating temperature	-40°F to +70°C [-40°C to +158°F]
Storage temperature	-40°F to +80°C [-40°C to +176°F]
Environmental sealing	IP 66
Operating force	3 N [0.674 lbf]

**Push Button Wiring Details**

*Push Button Switches*

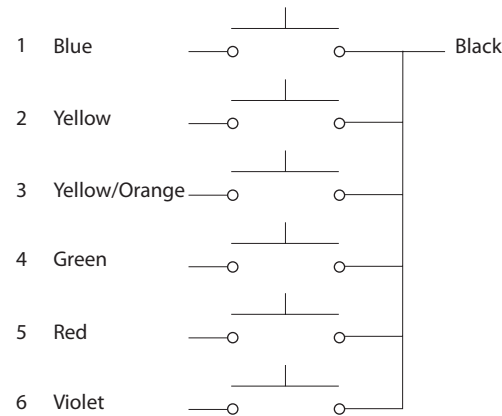

*Top Switch*

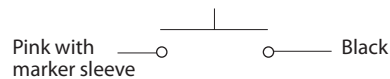

*Operator Presence Switch*



2250

**A Grip  
 (continued)**

**Connector Pin Assignments**

**▲ Warning**

Potential uncommanded machine movement. JS6000 base and grip pinout specifications are a function of joystick base measurement sensor type and electrical output (analog or CAN). For joysticks with analog output, the pinout assignments for the 12 and 16 pin connectors depend on whether a potentiometer or Hall sensor is used to measure the position of the joystick shaft. If a potentiometer sensor is used, the 12 pin connector is used for grip outputs. If a Hall sensor is used, the 16 pin connector is used for grip outputs and pins 13 through 16 are not used. Refer to the *Rocker Switch Wiring Details*, page 27 for information regarding the switch nomenclature used below. Refer to *Front Plate Model Code Designation*, page 25 for information regarding the location nomenclature for push button switches.

*A Grip Button Position Designations*

- Pins 13 to 16 are not used on the 16 pin connector
- Blank = Pin not used

	Pin number															
	1	2	3	4	5	6	7	8	9	10	11	12	13	14	15	16
A000																
A00T					Top switch						Common					
A00D								Operator presence			Common	Operator presence				
A00B					Top switch			Operator presence			Common	Operator presence				
A0L0	Switch out L	Switch out L			VoutL	Center tap	V+			V-	Common					
A0LD	Switch out L	Switch out L			VoutL	Center tap	V+	Operator presence		V-	Common	Operator presence				
A0LT	Switch out L	Switch out L			VoutL	Center tap	V+		Top switch	V-	Common					
A0LB	Switch out L	Switch out L			VoutL	Center tap	V+	Operator presence	Top switch	V-	Common	Operator presence				
A0R0			Switch out R	Switch out R		Center tap	V+		VoutR	V-	Common					
A0RD			Switch out R	Switch out R		Center tap	V+	Operator presence	VoutR	V-	Common	Operator presence				
A0B0	Switch out L	Switch out L	Switch out R	Switch out R	VoutL	Center tap	V+		VoutR	V-	Common					
A0BD	Switch out L	Switch out L	Switch out R	Switch out R	VoutL	Center tap	V+	Operator presence	VoutR	V-	Common	Operator presence				
A0H0	Switch out H			Switch out H	VoutH	Center Tap	V+			V-	Common					
A0HD	Switch out H			Switch out H	VoutH	Centertap	V+	Operator presence		V-	Common	Operator presence				

**A Grip  
 (continued)**

**Connector Pin Assignments (continued)**

*A Grip Button Position Designations*

- Pins 13 to 16 are not used on the 16 pin connector
- Blank = Pin not used

	Pin number															
	1	2	3	4	5	6	7	8	9	10	11	12	13	14	15	16
A0RT			Switch out R	Switch out R	Top switch	Center tap	V+		VoutR	V-	Common					
A100				PB1							Common					
A10T				PB1	Top switch						Common					
A10D				PB1				Operator presence			Common	Operator presence				
A10B				PB1	Top switch			Operator presence			Common	Operator presence				
A1L0	Switch out L	Switch out L		PB1	VoutL	Center tap	V+			V-	Common					
A1R0		PB3	Switch out R	Switch out R		Center tap	V+		VoutR	V-	Common					
A1H0	Switch out H		PB2	Switch out H	VoutH	Center top	V+			V-	Common					
A1LD	Switch out L	Switch out L		PB1	VoutL	Center tap	V+	Operator presence		V-	Common	Operator presence				
A1RD		PB3	Switch out R	Switch out R		Center tap	V+	Operator presence	VoutR	V-	Common	Operator presence				
A1HD	Switch out H		PB2	Switch out H	VoutH	Center top	V+	Operator presence		V-	Common	Operator presence				
A1RT		PB3	Switch out R	Switch out R	Top switch	Center tap	V+		VoutR	V-	Common					
A1LT	Switch out L	Switch out L		PB1	VoutL	Center tap	V+		Top switch	V-	Common					
A1RB		PB3	Switch out R	Switch out R	Top switch	Center tap	V+	Operator presence	VoutR	V-	Common	Operator presence				
A1LB	Switch out L	Switch out L		PB1	VoutL	Center tap	V+	Operator presence	Top switch	V-	Common	Operator presence				
A200		PB3	PB2								Common					
A20T		PB3	PB2		Top switch						Common					
A20D		PB3	PB2					Operator presence			Common	Operator presence				
A20B		PB3	PB2		Top switch			Operator presence			Common	Operator presence				
A2L0	Switch out L	Switch out L	PB2	PB1	VoutL	Center tap	V+			V-	Common					

**A Grip  
 (continued)**

**Connector Pin Assignments (continued)**

*A Grip Button Position Designations*

- Pins 13 to 16 are not used on the 16 pin connector
- Blank = Pin not used

	Pin number															
	1	2	3	4	5	6	7	8	9	10	11	12	13	14	15	16
A2R0	PB4	PB3	Switch out R	Switch out R		Center tap	V+			VoutR	V-	Common				
A2H0	Switch out H	PB3	PB2	Switch out H	VoutH	Center tap	V+				V-	Common				
A2LD	Switch out L	Switch out L	PB2	PB1	VoutL	Center tap	V+	Operator presence			V-	Common	Operator presence			
A2RD	PB4	PB3	Switch out R	Switch out R		Center tap	V+	Operator presence		VoutR	V-	Common	Operator presence			
A2HD	Switch out H	PB3	PB2	Switch out H	VoutH	Center tap	V+	Operator presence			V-	Common	Operator presence			
A2RB	PB4	PB3	Switch out R	Switch out R	Top switch	Center tap	V+	Operator presence		VoutR	V-	Common	Operator presence			
A2RT	PB4	PB3	Switch out R	Switch out R	Top switch	Center tap	V+			VoutR	V-	Common				
A2LB	Switch out L	Switch out L	PB2	PB1	VoutL	Center tap	V+	Operator presence	Top switch		V-	Common	Operator presence			
A2LT	Switch out L	Switch out L	PB2	PB1	VoutL	Center tap	V+		Top switch		V-	Common				
A300		PB3	PB2	PB1								Common				
A30T		PB3	PB2	PB1	Top switch							Common				
A30D		PB3	PB2	PB1				Operator presence				Common	Operator presence			
A30B		PB3	PB2	PB1	Top switch			Operator presence				Common	Operator presence			
A3R0	PB4	PB3	Switch out R	Switch out R		Center tap	V+	PB5		VoutR	V-	Common				
A3RD	PB4	PB3	Switch out R	Switch out R	PB5	Center tap	V+	Operator presence		VoutR	V-	Common	Operator presence			
A3L0	Switch out L	Switch out L	PB2	PB1	VoutL	Center tap	V+			PB6	V-	Common				
A3LD	Switch out L	Switch out L	PB2	PB1	VoutL	Center tap	V+	Operator presence		PB6	V-	Common	Operator presence			
A3RT	PB4	PB3	Switch out R	Switch out R	Top switch	Center tap	V+	PB5		VoutR	V-	Common				
A3LT	Switch out L	Switch out L	PB2	PB1	VoutL	Center tap	V+	PB6		Top switch	V-	Common				
A400	PB4	PB3	PB2	PB1								Common				

**A Grip  
 (continued)**

**Connector Pin Assignments (continued)**

*A Grip Button Position Designations*

- Pins 13 to 16 are not used on the 16 pin connector
- Blank = Pin not used

	Pin number															
	1	2	3	4	5	6	7	8	9	10	11	12	13	14	15	16
A40T	PB4	PB3	PB2	PB1	Top switch						Common					
A40D	PB4	PB3	PB2	PB1				Operator presence			Common	Operator presence				
A40B	PB4	PB3	PB2	PB1	Top switch			Operator presence			Common	Operator presence				
A500	PB4	PB3	PB2	PB1				PB5			Common					
A50D	PB4	PB3	PB2	PB1	PB5			Operator presence			Common	Operator presence				
A50B	PB4	PB3	PB2	PB1	Top switch			Operator presence	PB5		Common	Operator presence				
A50T	PB4	PB3	PB2	PB1	Top switch			PB5			Common					
A600	PB4	PB3	PB2	PB1	PB5				PB6		Common					
A60D	PB4	PB3	PB2	PB1	PB5			Operator presence	PB6		Common	Operator presence				
A60B	PB4	PB3	PB2	PB1	Top switch	PB5		Operator presence	PB6		Common	Operator presence				
A60T	PB4	PB3	PB2	PB1	Top switch			PB5	PB6		Common					

**Dimensions**

*A grip dimensions in millimeters [inches].*

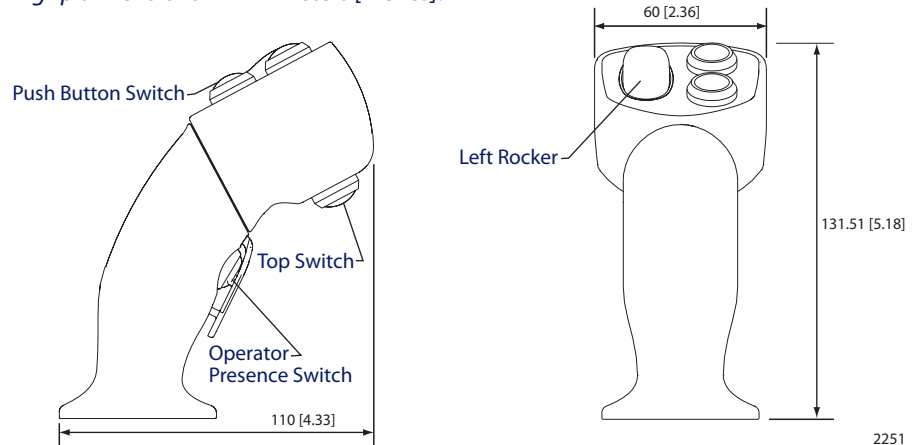

2251



**MG Grip**

MG Joystick Grip



**Product overview**

The MG multi-function grip is designed to provide an ergonomic solution to grip applications requiring an *operator presence* function. The profile of the MG grip ensures that the operators fingers are always close to the buttons to minimize operator fatigue and maximize functional control. An optional hand rest feature is also available to further minimize operator fatigue and provide additional protection for the joystick boot.

The grip is available with or without an *operator presence* lever switch, as well as up to two low current switches at the top of the grip. If two top switches are present, they are actuated through a rocker assembly.

0 Switch Option with Operator Presence Lever

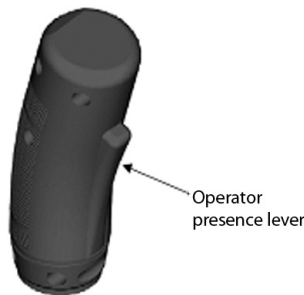

1 Switch Option with Operator Presence Lever

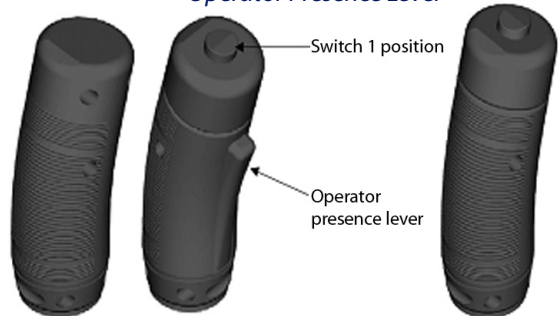

2 Switch Option with Operator Presence Lever

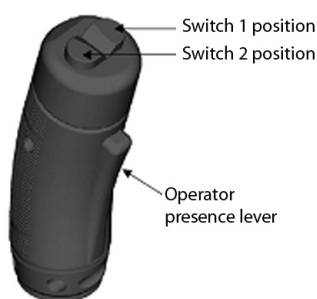

Grip with Hand Rest Option

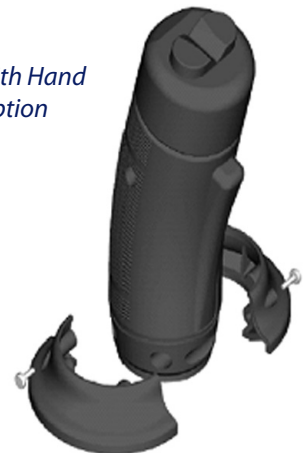

2257

**MG Grip  
 (continued)**

**Model Code Nomenclature**

Grip and grip options are specified using the Sauer-Danfoss joystick model code. For grips designed to mate with the JS6000 joystick base, use code positions I, J and K to specify grip properties. Reference *JS6000 grip product configuration model code*, pages 18 to 19.

MG grip model codes do not use model code positions J through S.

*Model Code for MG Grip Switch Positions*

Code	Switch position*	Operator presence lever	Hand rest
MG00	No switches	No lever	No hand rest
MG01	Switch 1	No lever	No hand rest
MG02	Switch 1, 2	No lever	No hand rest
MG03	Switch 1,2	Included	No hand rest
MG04	Switch 1,2	Included	Included
MG05	Switch 1	Included	Included
MG06	Switch 1,2	No lever	Included
MG07	Switch 1	No lever	Included
MG08	Switch 1	Included	No hand rest
MG09	No switches	Included	Included
MG10	No switches	No lever	Included
MG11	No switches	Included	No hand rest

\*Refer to Dimensions, page 36, for definition of switch locations.

**Specifications**

*Electrical Specifications*

Description	Specification
Contact resistance	50Ω
Contact bounce	1 ms
Insulation resistance	>100 MΩ at 50 Vdc
Dielectric strength	500 V (50 Hz, 1 min.)
Switching current	Max: 100 mA Min : 10 μA
Switching voltage	Max: 30 Vdc Min: 2 Vdc
Electrical life	1 million cycles at maximum voltage

*Environmental Specifications*

Description	Specification
Operating temperature	-25°C to +75°C [-13°F to +167°F]
Storage temperature	-30°C to +80°C [-22°F to +178°F]
Ingress protection	IP 67 ( <i>operator presence lever may not operate in icing conditions</i> )

**MG Grip  
 (continued)**

**Connector Pin Assignments**

**▲ Warning**

Potential uncommanded machine movement. JS6000 base and grip connector pin assignments are a function of joystick base shaft measurement sensor type and base electrical output (analog or CAN). For joysticks with analog output, the pin assignments for the 12 and 16 pin base connectors depend on whether a potentiometer or Hall sensor is used to measure the position of the joystick shaft. If a potentiometer sensor is used, the 12 pin connector is used for grip outputs. If a Hall sensor is used, the 16 pin connector is used for grip outputs.

*12 Pin Connector MG Grip Pin Assignments*

Pin number	Description
1	Not used
2	Not used
3	Switch 2
4	Operator presence
5	Operator presence
6	Switch 1
7	Not used
8	Not used
9	Not used
10	Not used
11	Not used
12	Common for switch 1, 2

*16 Pin Connector MG Pin Assignments*

Pin number	Description
1	Not used
2	Not used
3	Switch 2
4	Operator presence
5	Operator presence
6	Switch 1
7	Not used
8	Not used
9	Not used
10	Not used
11	Not used
12	Common for switch 1,2
13	Not used
14	Not used
15	Not used
16	Not used

**MG Grip**  
**(continued)**

**Switch Wiring Details**

*1 Switch Option*

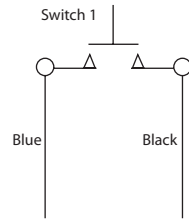

*2 Switch Option*

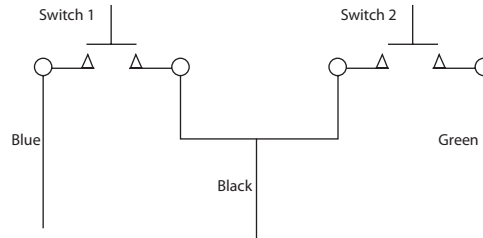

*Operator Presence Switch*

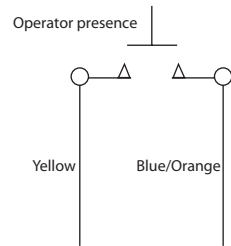

2255

**Dimensions**

*MG grip dimensions in millimeters [inches].*

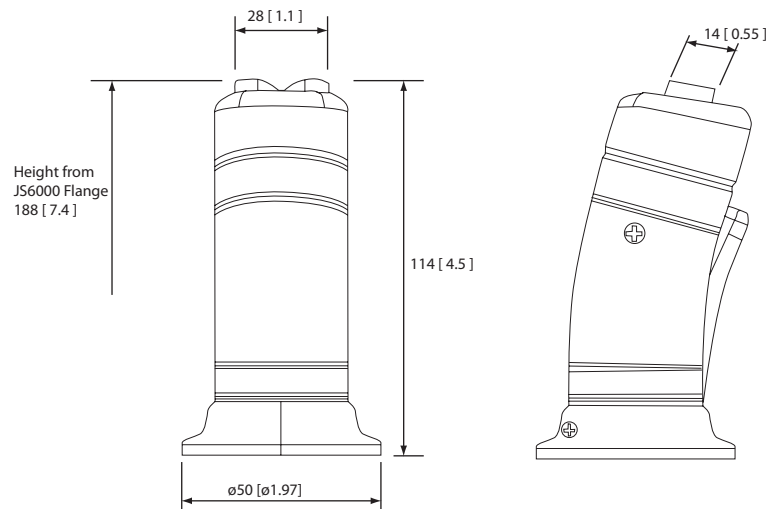
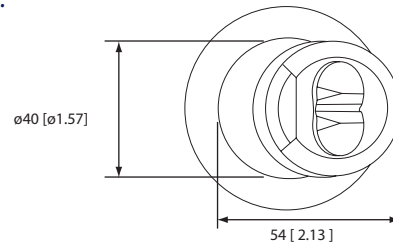

2256

**HKN Grip**



*HKN Joystick Grip*

**Product Overview**

The HKN grip is a plain, high impact plastic knob grip that has no electrical interface. It is designed to provide a comfortable grip for extended machine operation.

**Model Code Nomenclature**

Grip and grip options are specified using the Sauer-Danfoss joystick model code. For grips designed to mate with the JS6000 joystick base, use code positions I, through S to specify grip properties. Reference *JS6000 Grip Product Configuration Model Code*, pages 19 to 21.

---

The HKN does not use master model code positions J through S.

---

The master model code for HKN grips is HKN0.

**Specifications**

*Environmental Specifications*

Description	Specification
Operating temperature	-40°C to +80°C [-40°F to +176°F]
Storage temperature	-40°C to +85°C [-40°F to +185°F]
Environmental sealing	IP 66

**Dimensions**

*HKN Grip Dimensions*

Maximum height above flange	Maximum diameter
45 mm [1.76 in]	34.6 mm [1.36 in]

## JS1000, JS6000 Joystick Grips

### Technical Information

### Grip and Joystick Base Service Parts

#### Service Part Information

Service part availability for JS1000 joystick is a function of joystick base and grip specifications. Refer to the *JS1000 Base Technical Information* manual **520L0826** for mating connector part information. Refer to the table below for service part information.

#### *JS1000 Joystick Grip and Base Service Parts*

Grip type	Part description	Replacement part ordering number
JS1000 ball grip	Boot	10103388
	Ball grip	10101913
	Grip fastening screw	10101782
JS1000 grip with switch, rocker and banana	Rocker switch cover	10101816
	Banana switch cover	10103337
JS1000 PRO grip	No replacement parts available	



JS1000, JS6000 Joystick Grips  
Technical Information  
Notes



## OUR PRODUCTS

Hydrostatic transmissions  
Hydraulic power steering  
Electric power steering  
Electrohydraulic power steering  
Closed and open circuit axial piston pumps and motors  
Gear pumps and motors  
Bent axis motors  
Orbital motors  
Transit mixer drives  
Proportional valves  
Directional spool valves  
Cartridge valves  
Hydraulic integrated circuits  
Hydrostatic transaxles  
Integrated systems  
Fan drive systems  
Electrohydraulics  
Microcontrollers and software  
Electric motors and inverters  
Joysticks and control handles  
Displays  
Sensors

## Sauer-Danfoss Mobile Power and Control Systems – Market Leaders Worldwide

Sauer-Danfoss is a comprehensive supplier providing complete systems to the global mobile market.

Sauer-Danfoss serves markets such as agriculture, construction, road building, material handling, municipal, forestry, turf care, and many others.

We offer our customers optimum solutions for their needs and develop new products and systems in close cooperation and partnership with them.

Sauer-Danfoss specializes in integrating a full range of system components to provide vehicle designers with the most advanced total system design.

Sauer-Danfoss provides comprehensive worldwide service for its products through an extensive network of Global Service Partners strategically located in all parts of the world.

Local address:

Sauer-Danfoss (US) Company  
2800 East 13th Street  
Ames, IA 50010, USA  
Phone: +1 515 239-6000  
Fax: +1 515 239-6618

Sauer-Danfoss GmbH & Co. OHG  
Postfach 2460, D-24531 Neumünster  
Krokamp 35, D-24539 Neumünster, Germany  
Phone: +49 4321 871-0  
Fax: +49 4321 871 122

Sauer-Danfoss ApS  
DK-6430 Nordborg, Denmark  
Phone: +45 7488 4444  
Fax: +45 7488 4400

Sauer-Danfoss-Daikin LTD  
Sannomiya Grand Bldg. 8F  
2-2-21 Isogami-dori, Chuo-ku  
Kobe, Hyogo 651-0086, Japan  
Phone: +81 78 231 5001  
Fax: +81 78 231 5004