

CONTENTS

Introduction	3
Sectional drawing	4
Function.....	5
Technical data.....	6
PVP Pump side module with T0	7
PVBZ basic module with T0	8
PVB basic module with T0.....	7
Standard spools for PVBZ	9
Standard FC- spools for PVBZ (electrical and mechanical actuation)	10
Standard Float spools for PVBZ (electrical actuation)	10
PVEH-F Electrical actuation.....	10
PVST, end plate	10
Hydraulic diagrams.....	11
Actuation.....	12
Dimensions.....	13
Specification Sheet PVBZ.....	14
Specification Sheet HPCO	15

© 2008 Sauer-Danfoss. All rights reserved. Printed in Europa
Sauer-Danfoss accepts no responsibility for possible errors in catalogs, brochures and other printed material. Sauer-Danfoss reserves the right to alter its products without prior notice. This also applies to products already ordered provided that such alterations aren't in conflict with agreed specifications. All trademarks in this material are properties of their respective owners. Sauer-Danfoss and the Sauer-Danfoss logotype are trademarks of the Sauer-Danfoss Group.

Front cover illustrations: F301054,
Drawing: 157-582

PVBZ

With the introduction of basic module PVBZ, Sauer-Danfoss can now supply basic modules with integrated pilot operated check valves.

The PVBZ load compensated module is developed for applications, where integrated pilot operated check valves in the work ports are required to limit the work port leakage down to a minimum (below 1 cm³ [0.06 in³] per minute).

The new PVBZ basic module can only be mixed with basic modules PVB and PVP pump-side modules mentioned in this Tech Note and offers the following features:

- Integrated pilot operated check valves for low internal leakage
- Integrated thermal relief valve
- Standard 4/3 spools
- 4/4 float spools
- Interchangeable spools

PVP WITH INTEGRATED HPCO

Together with the introduction of PVBZ (and PVB with separate tank line T0) Sauer-Danfoss can now also supply PVG 32 valves with integrated HPCO functionality (**H**igh **P**ressure **C**arry **O**ver).

The HPCO function will guide the pump flow not used in the PVG 32 valve group via the HPCO port to for example a directional valve.

The new PVP pump side module with integrated HPCO function can only be mixed with PVB, PVBZ and PVST mentioned in this Tech Note and offers the following features:

- HPCO functionality
- Prioritized flow for PVG 32
- Reduced plumbing

SECTIONAL DRAWING

- 1 Pressure relief valve
- 2 Pressure reduction valve for pilot oil supply
- 3 Pressure gauge connection
- 4 Plug, open centre
- 5 Orifice, closed centre
- 6 Pressure adjustment spool
- 7 Plug, closed centre
- 8 LS connection
- 9 T0 connection
- 10 Plug - to be removed for internal T0 (157B5130, 157B5131, 157B5330 and 157B5331 only)
- 11 LS signal
- 12 Pilot valve for POC
- 13 Shuttle valve
- 14 Pilot operated check valve, POC
- 15 Main spool
- 16 Compensator
- 17 Shuttle pin
- 18 Max. oil adjustment screws for ports A and B
- 19 Pilot supply for PVE
- 20 Separate tank line, (T0)

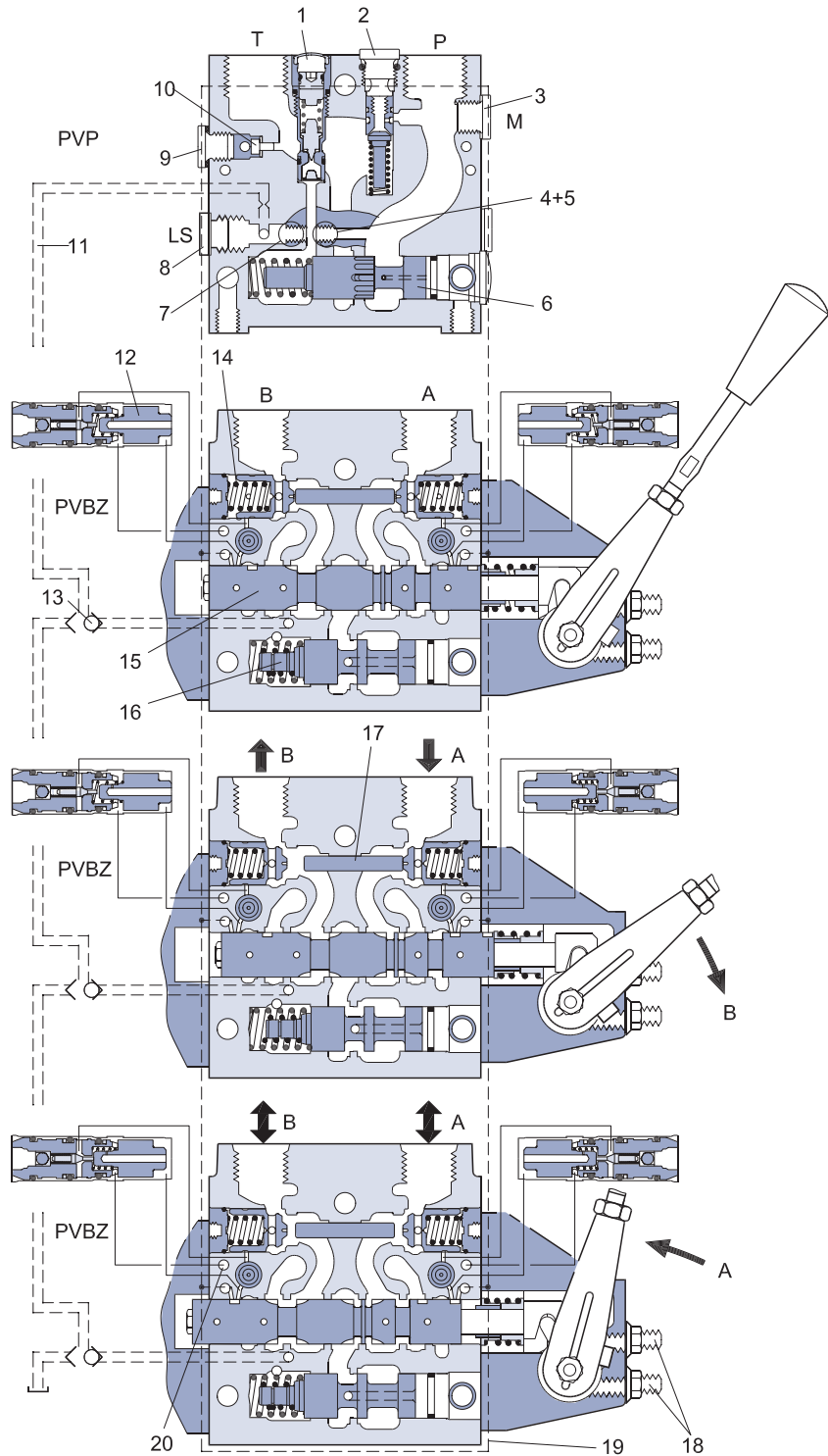

157-633.10

FUNCTION

When main spools (15) are in neutral position, the pilot operated check valves (hereafter POC) are kept closed by a spring plus the work port load, which is directed to the spring side of the POC (14) via a small orifice.

If a main spool is actuated to have flow out of the B port, the meter out flow forces the respective POC valve to open. At the same time, pilot pressure is guided via the main spool to the back side of a small pilot valve (12) on the A port side. This will ensure, that the load pressure behind the POC is released to a separate tank T0 (20) via a seat valve and allow the POC to open and let return flow pass across the main spool back to tank. For float function, both POC are released to tank at the same time like described above. In some applications with 3/3 spools and low load pressure (eg. Hitch applications), it is necessary to force open the POC by a pin (17). This pin is actuated by means of pump pressure on the A portside.

Note: PVBZ modules cannot be option mounted (PVM on B - Port side).

The separate tank connection T0 is needed to ensure proper performance of the POC's regardless of the pressure in main tank line T. It is therefore necessary to connect the T0 port (9) in the Inlet PVP directly to the oil reservoir with a separate hose.

Thermal relief valves (157B6261, 157B6262, 157B6266 157B6661, 157B6662 and 157B6666) can be integrated to ensure that unintended high pressure between POC and cylinder/motor is not built up by means of external heat source. The setting of the thermal relief is fixed to 276 bar [4003 psi], max. capacity 1 l/min [0.264 US gal/min].

Note: If tank connection T0 is not used, plug (10) must be removed. Pos 10 is not part of 157B5132, 157B5133, 157B5332 and 157B5333 and therefore T0-port (9) in 157B5132, 157B5133, 157B5332 and 157B5333 must always be connected to tank. PVBZ can only be used in combination with PVB and PVP mentioned in this Tech Note.

When using PVB, PVBZ and PVP (157B5140, 157B5142, 157B5340 and 157B5342 only) with separate tank line T0 it is possible to pressurize the tank port in PVP having HPCO function.

Return flow from A and B ports of PVG 32 must be guided to tank via separate tank port in the end plate PVST (157B2500 and 157B2520).

T0 tank port in PVP 157B5140, 157B5142, 157B5340 and 157B5342 must always be connected to tank, see hydraulic diagram page 11 and according specification page 15.

TECHNICAL DATA

Max. pressure	Port P continuous	210 bar	[3045 psi]
	Port A/B	210 bar	[3045 psi]
	Port T, static/dynamic	25 bar/40 bar	[365/580 psi]
Oil flow, rated	Port P	140 l/min	[37 US gal/min]
	Port A/B, with press. comp.	100 l/min	[26.4 US gal/min]
	Port A/B, without press. comp.	125 l/min	[33 US gal/min]
Spool travel, standard		± 7 mm	[±0.28 in]
Spool travel, float position spool	Proportional range	± 5.5 mm	[±0.22 in]
	Float position	7.5 mm	[±0.30 in]
Dead band, flow control spool	Standard	± 0.8 mm	[±0.03 in]
Max. internal leakage at 200 bar [2900 psi] and 21 mm ² /s [102 SUS]	A/B → T	1 cm ³ /min	[0.06 in ³ /min]
Oil temperature (inlet temperature)	Recommended temperature	30 → 60°C	[86 → 140°F]
	Min. temperature	-30°C	[-22°F]
	Max. temperature	+90°C	[194°F]
Ambient temperature		-30 → +60°C	[-22 → +140°F]
Oil viscosity	Operating range	12 - 75 mm ² /s	[65 - 347 SUS]
	Min. viscosity	4 mm ² /s	[39 SUS]
	Max. viscosity	460 mm ² /s	[2128 SUS]
Filtration	Max. contamination (ISO 4406)	18/16/13	18/16/13

VERSIONS AND CODE NUMBERS

Symbol	Description PVP	Code number	
		BSP versions	SAE versions
<p>157-600.10</p>	<p>Open centre pump side module for pumps with fixed displacement</p> <p>External T0</p> <p>Possible to connect T0 to internal tank</p> <p>With pilot supply for electrical actuation</p>	157B5130	157B5330
<p>157-603.10</p>	<p>Closed centre pump side module for pumps with variable displacement</p> <p>External T0</p> <p>Possible to connect T0 to internal tank</p> <p>With pilot supply for electrical actuation</p>	157B5131	157B5331
<p>157-601.10</p>	<p>Open centre pump side module for pumps with fixed displacement</p> <p>External T0</p> <p>With pilot supply for electrical actuation and connection for pilot oil pressure.</p> <p>Facility for LS unloading valve, PVPX</p>	157B5132	157B5332
<p>157-602.10</p>	<p>Closed centre pump side module for pumps with variable displacement</p> <p>External T0</p> <p>With pilot supply for electrical actuation and connection for pilot oil pressure.</p> <p>Facility for LS unloading valve, PVPX</p>	157B5133	157B5333
<p>157-676.11</p>	<p>Open centre pump side module for pumps with fixed displacement</p> <p>External T0</p> <p>With pilot supply for electrical actuation</p> <p>Blocked T line for HPCO</p>	157B5140	157B5340
<p>157-673.10</p>	<p>Open centre pump side module for pumps with fixed displacement</p> <p>External T0</p> <p>With pilot supply for electrical actuation and connection for pilot oil pressure.</p> <p>Facility for LS unloading valve, PVPX</p> <p>Blocked T line for HPCO</p>	157B5142	157B5342

Connection: P and T-port G 3/4 [1 1/16 in - 12]
For PVPX unloading valve, *see catalogue DKMH.PK.570.C3.02*

VERSION AND CODE NUMBERS

Symbol	Description PVBZ	Without thermal relief valve 157B...		With thermal relief valve 157B...	
		BSP	SAE	BSP	SAE
	<p>Without compensator and load drop check valve</p> <p>With pilot operated check valves on work port B</p> <p>Max. work port pressure = 210 bar [3045 psi]</p>	6051	6451	-	-
	<p>Without compensator and load drop check valve</p> <p>With pilot operated check valves on work port A and B</p> <p>Max. work port pressure = 210 bar [3045 psi]</p>	6052	6452	-	-
	<p>With compensator</p> <p>With pilot operated check valves on work port B</p> <p>Compensated work port flow A/B = 100 l/min [26.4 US gal/min]</p> <p>Max. work port pressure = 210 bar [3045 psi]</p>	6251	6651	6261	6661
	<p>With compensator</p> <p>With pilot operated check valves on work port A and B</p> <p>Compensated work port flow A/B = 100 l/min [26.4 US gal/min]</p> <p>Max. work port pressure = 210 bar [3045 psi]</p>	6252	6652	6262	6662
	<p>With compensator</p> <p>With pilot operated check valves on work port A and B</p> <p>LSA/B shuttle valve for float and shuttle pin</p> <p>Compensated work port flow A/B = 100 l/min [26.4 US gal/min]</p> <p>Max. work port pressure = 210 bar [3045 psi]</p>	-	-	6266	6666

Connection: A and B-port G 1/2 [7/8in - 14]

Seal kit for PVBZ 157B6989

VERSIONS AND CODE NUMBERS

Symbol	Description PVB	Code number 157B....			
		W/O PVLP 63		With PVLP 63	
		BSP	SAE	BSP	SAE
<p>157-591.11</p>	<p>Without load drop check valve and pressure compensator.</p> <p>Can be used where load holding valves prevent oil from floating back through the channel P.</p>	6010	6410	-	-
<p>157-592.11</p>	<p>Load drop check valve</p>	6110	6909	6140	6904
<p>157-593.11</p>	<p>With compensator valve</p>	6210	6922	6240	6906
<p>157-594.10</p>	<p>With compensator valve</p> <p>Adjustable LS A/B limiting valves.</p> <p>External LS connection port A/B.</p> <p>Also used for float position spools.</p>	6213	6613	6243	6643

Connection: A and B-port G 1/2 [7/8 in - 14]

END PLATE PVST

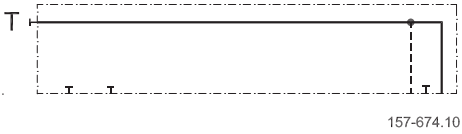
Code number 157B		BSP G 1/2	SAE 7/8 in - 14
	PVST without active elements Tank port connection	2500	2520

STANDARD FC-SPOOLS FOR PVBZ (ELECTRICAL AND MECHANICAL ACTUATION)

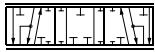
Code number 157B	Pressure compensated flow l/min [US gal/min]					
Symbol  157-636.11	5 [1.3]	10 [2.6]	25 [6.6]	40 [10.6]	65 [17.2]	100 [26.4]
4-way, 3-position	9405	9400	9401	9402	9403	9404

Spools for PVB, *see catalogue DKMH.PK.570.C3.02*

STANDARD FLOAT SPOOLS FOR PVBZ (ELECTRICAL ACTUATION)

Code number 157B	Pressure compensated flow l/min [US gal/min]					
Symbol  157-635.11	5 [1.3]	10 [2.6]	25 [6.6]	40 [10.6]	65 [17.2]	100 [26.4]
4-way, 3-position Float P > A > F	9415	9410	9411	9412	9413	9414

Float spools to be used in combination with PVBZ modules, 157B6266 and 157B6666 only.
Float spools for PVB, *see catalogue DKMH.PK.570.C3.02*

PVEH-F ELECTRICAL ACTUATION

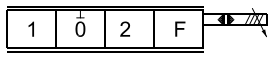
Code number 157B		
 157-190.10	PVEH-F Proportional high active fault monitoring multivoltage 11 - 32, Float P>A>F	4338*

* 6-pin AMP connector including 4 m [13 ft] cable can be ordered using code number 157B4974
For standard electrical actuators, *see catalogue DKMH.PK.570.A2.02*

**PVG 32 VALVE GROUP
WITH BASIC MODULS
PVBZ INCLUDING
INTEGRATED PILOT
OPERATED CHECK
VALVES**

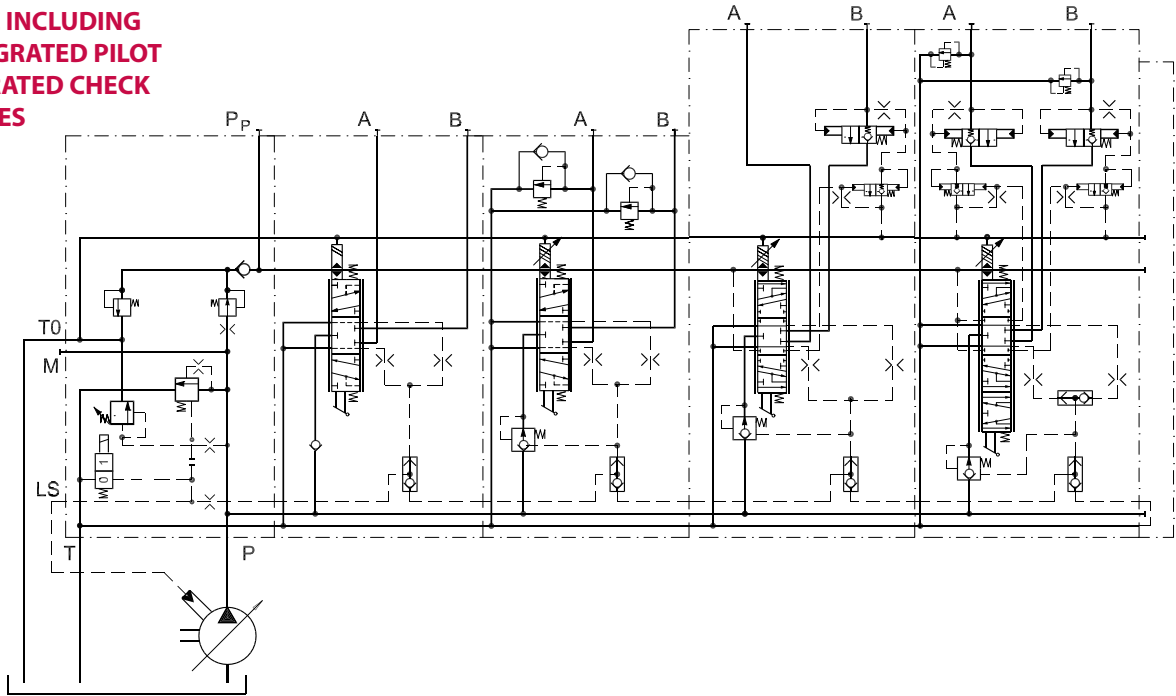

157-637.11

**PVG 32 VALVE GROUP
WITH INTEGRATED HPCO
(HIGH PRESSURE CARRY
OVER)**

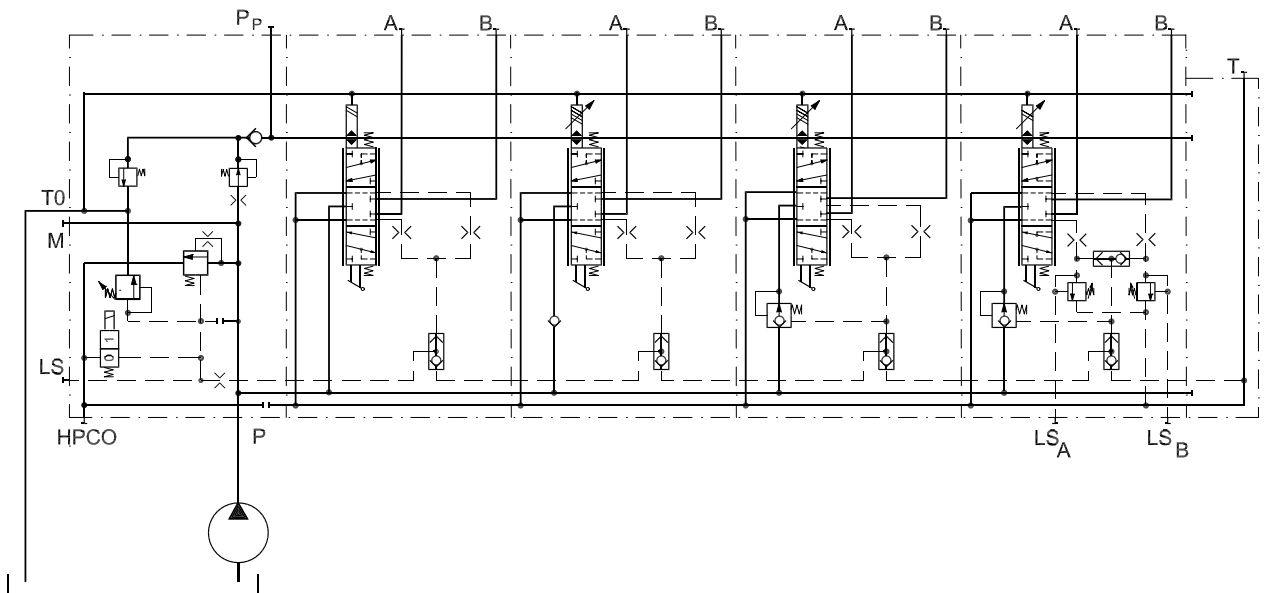

157-675.12

ACTUATION, PVEH - F

Function	U_s (pin 1)	Float (pin 5)
Neutral	$0.5 \times U_{DC}$	0
Q: -> A	$(0.5 \rightarrow 0.25) \times U_{DC}$	0
Q: -> B	$(0.5 \rightarrow 0.75) \times U_{DC}$	0
Float	None or any voltage $\leq U_{DC}$	U_{DC}

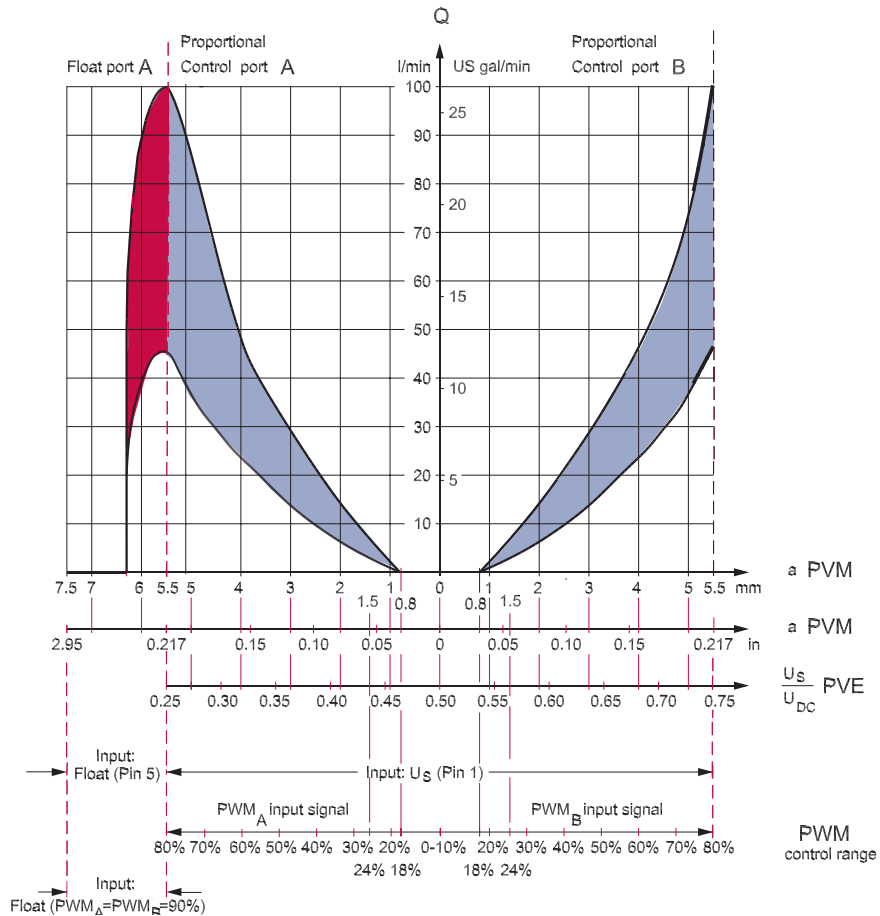
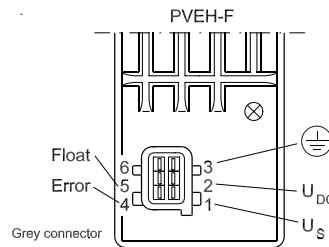

DIMENSIONS

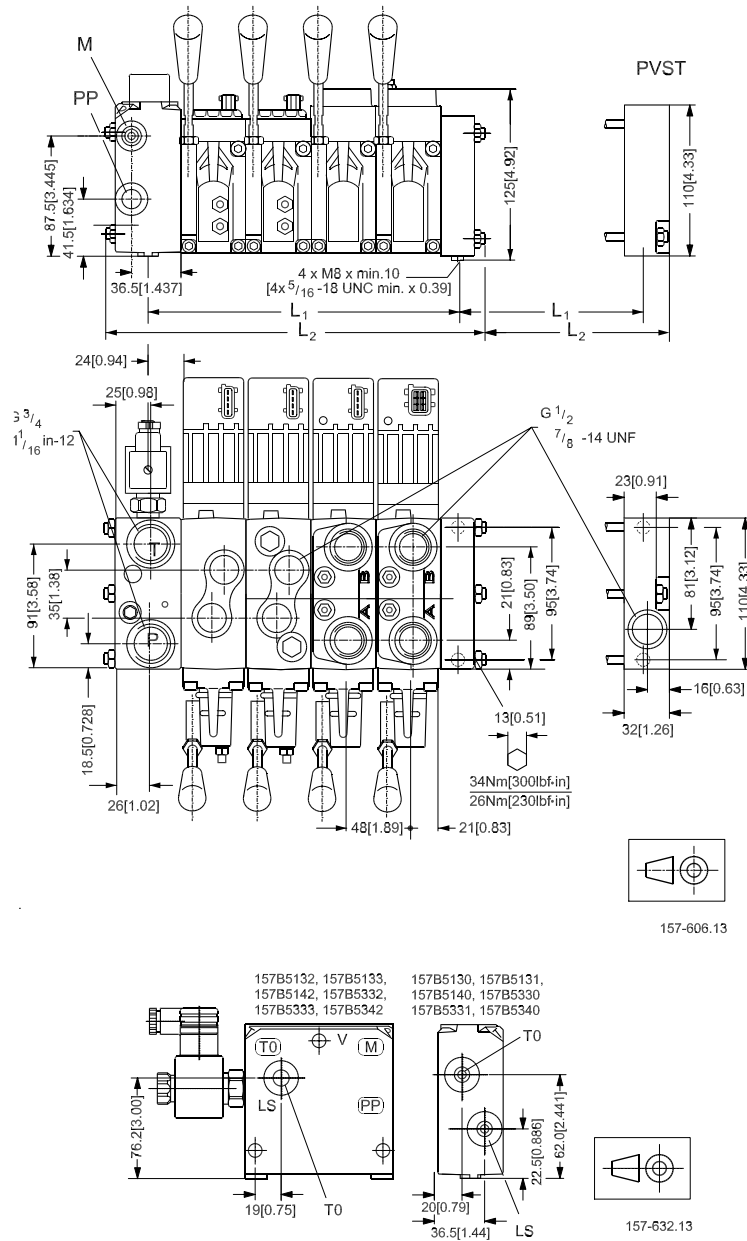

Port connection: T0, M, PP, LS
G1/4 [1/2 in - 20]

To have easier access to fittings when building valve groups with a mix of PVB and PVBZ, it is recommended to group PVB and PVBZ - *see also example* page 11.

PVB	1	2	3	4	5	6	7	8	9	10
L1 mm	82	130	178	226	274	322	370	418	466	514
[in]	3.23	5.12	7.01	8.90	10.79	12.68	14.57	16.46	18.35	20.24
L2 mm	140	189	238	287	336	385	434	483	532	581
[in]	5.51	7.44	9.37	11.30	13.23	15.16	17.09	19.02	20.95	22.87

Subsidiary/Dealer	PVG No.
Customer	Customer No.
Application	Revision No.

Function	A-Port	O	157B 5133	157B 4236	B-Port
			p = 210	bar 157B	
	a 157B 3171	1	157B 6010	157B 7003	13 157B 4228
	b 157B		LS _A	bar LS _B	bar 157B b
	a 157B 3171	2	157B 6240	157B 7004	13 157B 4734
	b 157B 2240		LS _A	bar LS _B	bar 157B 2240 b
	a 157B 3191	3	157B 6051	157B 9403	13 157B 4034
	b 157B		LS _A	bar LS _B	bar 157B b
	a 157B 3191	4	157B 6266	157B 9415	13 157B 4338
	b 157B		LS _A	bar LS _B	bar 157B b
	a 157B	5	157B	157B	13 157B
	b 157B		LS _A	bar LS _B	bar 157B b
	a 157B	6	157B	157B	13 157B
	b 157B		LS _A	bar LS _B	bar 157B b
	a 157B	7	157B	157B	13 157B
	b 157B		LS _A	bar LS _B	bar 157B b
	a 157B	8	157B	157B	13 157B
	b 157B		LS _A	bar LS _B	bar 157B b
	a 157B	9	157B	157B	13 157B
	b 157B		LS _A	bar LS _B	bar 157B b
	a 157B	10	157B	157B	13 157B
	b 157B		LS _A	bar LS _B	bar 157B b
Remarks		11	157B2000		
		12	157B8004		

Filled in by	Date
--------------	------

Subsidiary/Dealer	PVG No.
Customer	Customer No.
Application	Revision No.

Function	A-Port	0	157B 5142	157B4236	B-Port
			p = 210	bar 157B	
	a 157B 3171	1	157B 6010	157B 7001	13 157B 4901
	b 157B		LS _A	bar LS _B	bar 157B b
	a 157B 3171	2	157B 6110	157B 7002	13 157B 4734
	b 157B		LS _A	bar LS _B	bar 157B b
	a 157B 3193	3	157B 6210	157B 7003	13 157B 4034
	b 157B		LS _A	bar LS _B	bar 157B b
	a 157B 3193	4	157B 6213	157B 7024	13 157B 4834
	b 157B		LS _A 50	bar LS _B 150	bar 157B b
	a 157B	5	157B	157B	13 157B
	b 157B		LS _A	bar LS _B	bar 157B b
	a 157B	6	157B	157B	13 157B
	b 157B		LS _A	bar LS _B	bar 157B b
	a 157B	7	157B	157B	13 157B
	b 157B		LS _A	bar LS _B	bar 157B b
	a 157B	8	157B	157B	13 157B
	b 157B		LS _A	bar LS _B	bar 157B b
	a 157B	9	157B	157B	13 157B
	b 157B		LS _A	bar LS _B	bar 157B b
	a 157B	10	157B	157B	13 157B
	b 157B		LS _A	bar LS _B	bar 157B b
Remarks		11	157B2500		
		12	157B8004		

Filled in by	Date
--------------	------



OUR PRODUCTS

Hydrostatic transmissions
Hydraulic power steering
Electric power steering
Electrohydraulic power steering
Closed and open circuit axial piston pumps and motors
Gear pumps and motors
Bent axis motors
Orbital motors
Transit mixer drives
Planetary compact gears
Proportional valves
Directional spool valves
Cartridge valves
Hydraulic integrated circuits
Hydrostatic transaxles
Integrated systems
Fan drive systems
Electrohydraulic controls
Digital electronics and software
Sensors

Sauer-Danfoss Mobile Power and Control Systems – Market Leaders Worldwide

Sauer-Danfoss is a comprehensive supplier providing complete systems to the global mobile market.

Sauer-Danfoss serves markets such as agriculture, construction, road building, material handling, municipal, forestry, turf care, and many others.

We offer our customers optimum solutions for their needs and develop new products and systems in close cooperation and partnership with them.

Sauer-Danfoss specializes in integrating a full range of system components to provide vehicle designers with the most advanced total system design.

Sauer-Danfoss provides comprehensive worldwide service for its products through an extensive network of Authorized Service Centers strategically located in all parts of the world.

Sauer-Danfoss (US) Company
2800 East 13th Street
Ames, IA 50010, USA
Phone: +1 515 239-6000, Fax: +1 515 239 6618

Sauer-Danfoss (Neumünster) GmbH & Co. OHG
Postfach 2460, D-24531 Neumünster
Krokamp 35, D-24539 Neumünster, Germany
Phone: +49 4321 871-0, Fax: +49 4321 871 122

Sauer-Danfoss ApS
DK-6430 Nordborg, Denmark
Phone: +45 7488 4444, Fax: +45 7488 4400