

Technical  
Information

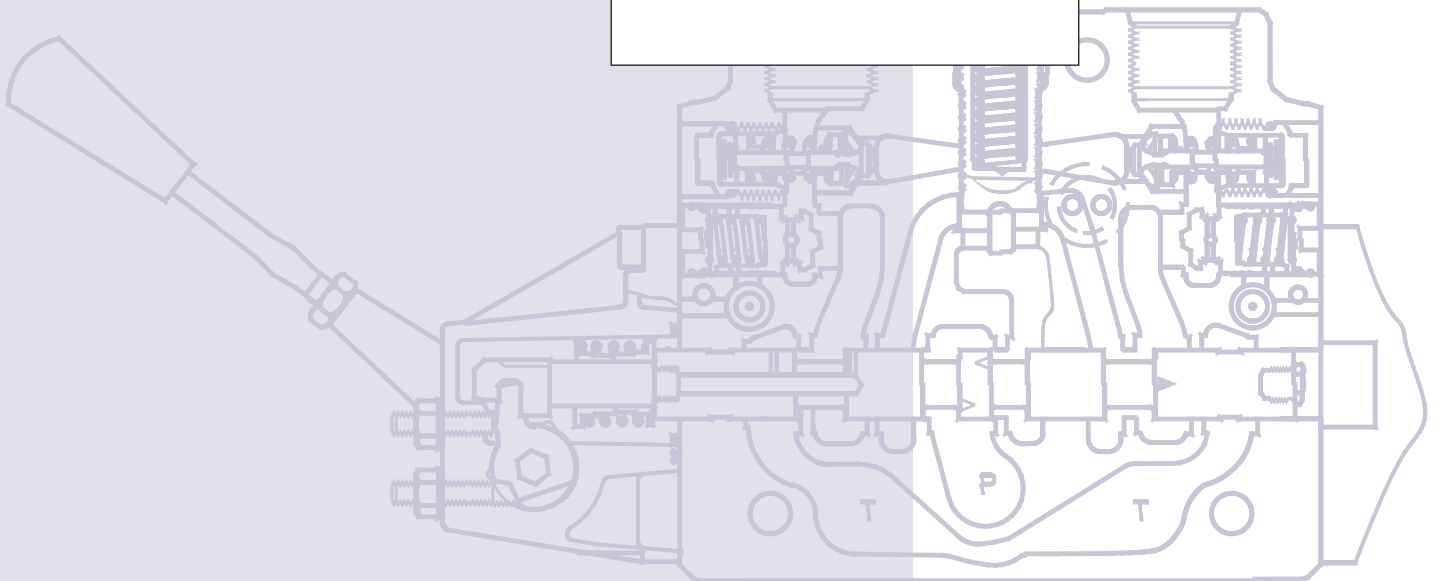
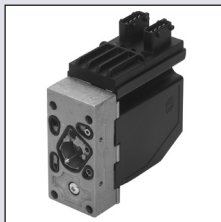

<b>GENERAL</b>	General .....	4
	Valve system .....	4
	General features PVG 100 .....	4
	PVP - Pump side module .....	4
	PVB – basic module.....	4
	Actuation modules.....	4
<b>FUNCTION PVG 100</b>	PVG 100 valve group with open center PVP .....	5
	PVG 100 valve group with closed center PVP .....	5
	PVG 100 sectional drawing .....	6
<b>TECHNICAL DATA</b>	PVG 100 Valve group.....	7
	PVH, hydraulic actuation.....	7
	PVM, mechanical actuation .....	8
	PVE, reaction time .....	8
	PVE, oil consumption and hysteresis.....	9
	PVEO.....	9
	PVEA, PVEH and PVES.....	9
<b>MODULES AND CODE NUMBERS</b>	PVP 100 inlet modules.....	10
	PVP 100 accessories for open center pump side modules.....	11
	PVB 100 basic modules .....	11
	PVB 32 Basic modules with T0 .....	12
	PVBZ 32 basic modules with T0 .....	13
	Code number for use on PVG 100 .....	14
	PVM, mechanical actuation .....	14
	PVMD, cover for mechanical actuation .....	14
	PVH, hydraulic actuation .....	14
	PVMR friction detent .....	14
	PVMF, mechanical float position.....	14
	PVE for PVG 100 .....	15
	PVLA, suction valve (fitted in PVB) .....	16
	PVL P, shock and suction valve (fitted in PVB) .....	17
	PVT 100 tank module .....	18
	PVTI 100/32 interface module.....	18
	Assembly kit PVG 100 / P VSI / PVT.....	18
	Assembly kit PVG 100 /PVTI interface module.....	18
	Assembly kit PVB 32 (combo PVG 100).....	18

© 2006 Sauer-Danfoss. All rights reserved. Printed in Europe.

Sauer-Danfoss accepts no responsibility for possible errors in catalogs, brochures and other printed material. Sauer-Danfoss reserves the right to alter its products without prior notice. This also applies to products already ordered provided that such alterations aren't in conflict with agreed specifications. All trademarks in this material are properties of their respective owners. Sauer-Danfoss and the Sauer-Danfoss logotype are trademarks of the Sauer-Danfoss Group.

Front cover illustrations: PA270004, F301102, F301196, F301197  
 Drawing: 157-691

<b>TECHNICAL CHARACTERISTICS</b>	General.....	19
	PVP, pump side module.....	19
	Open center flow rating.....	19
	PVB, Basic module.....	20
	PVLP, shock and suction valve.....	22
	PVLA, suction valve.....	22
<b>DIMENSIONS</b>	Valve dimension, PVG 100, open center PVP.....	23
	Valve dimension, PVG100 / 32, closed center.....	24
	Valve dimension, PVG 100, closed center PVP with integrated priority valve.....	25
	General dimensions.....	26
<b>HYDRAULIC SYSTEMS</b>	Hydraulic systems.....	27
<b>OTHER OPERATING CONDITIONS</b>	Oil.....	28
	Mineral oil.....	28
	Non-flammable fluids.....	28
	Biodegradable oils.....	28
	Particle content, degree of contamination.....	28
	Filtration.....	29
	System filters.....	29
	Internal filters.....	29
<b>MODULES AND CODE NUMBERS</b>	Standard spools (elec. and mechanical actuation).....	30
	Standard spools (Hydraulic actuation).....	30
	Spools for friction detent PVMR.....	31
	Spools for mechanical float position PVMF.....	31
<b>MODULE SELECTION CHART</b>	Module selection chart.....	32
<b>ORDER SPECIFICATION</b>	Order specification.....	34
<b>SPECIFICATION SHEET</b>	Specification Sheet.....	35

## GENERAL

### Valve system

PVG 100 is a hydraulic load sensing valve, designed to fulfill customer requirements. From a simple load sensing directional valve to an advanced electro hydraulic controlled load independent proportional valve.

The PVG 100 modular system makes it possible to build up a valve group to fulfill customer requirements.

The compact external dimensions of the valve remains unchanged whatever combination is specified.

### General features PVG 100

- Load independent flow control
  - Oil flow to an individual function is independent of the load on this function
  - Oil flow to one function is independent of the load pressure of other functions
- Anti – saturation (flow sharing)
  - In case of anti saturation, pump flow is shared between all functions, independent of load.
- Good regulation characteristics
- Up to 8 PVB 100 basic modules per valve group
- Up to 10 PVB 100/32 basic modules per valve group
- BSP and UNF connection threads

### PVP - Pump side module

- Build in load sense relief valve
- System pressure up to 350 bar (5075 psi)
- Full Flow dump valve (open center only)
- Pilot supply shut off
- Versions
  - Open center version for systems with fixed displacement pumps
  - Closed center versions for systems with variable displacement pump
  - Integrated priority valve
- Integrated pilot supply valve
- Accumulator gauge connection
- Pressure gauge connection
- Pilot gauge connection

### PVB – basic module

- Integrated pilot operated check valves in A and B work ports for low internal leakage
- Integrated pressure compensator
- Interchangeable spools
- Depending on requirements the basic module can be supplied with :
  - Shock/suction valves
  - Different spools

### Actuation modules

The basic module is always fitted with mechanical actuator PVM, which can be combined with the following as required:

- Electrical actuator
  - PVES – super proportional
  - PVEH – proportional high
  - PVED – Can-bus interface
  - PVEA – proportional, fine
  - PVEO – ON/OFF
- PVH, cover for hydraulic actuation
- PVMD, for mechanical actuation
- PVMR, for friction detent
- PVMF, for mechanical detent, float

**PVG 100 VALVE GROUP  
WITH OPEN CENTER PVPF**

When the pump is started and the main spools in the individual basic modules are in the neutral position, oil flows from the pump, through connection P, across the pressure matching spool to tank. The oil flow led across the pressure matching spool determines the pump pressure (stand-by pressure).

When one or more of the main spools are actuated, the highest load pressure is fed through the shuttle valve circuit to the spring chamber behind the pressure matching spool, and completely or partially closes the connection to tank.

Pump pressure is applied to the opposite side of the pressure matching spool.

The pressure relief valve will open should the load pressure exceed the set value, diverting pump flow back to tank.

In a pressure-compensated basic module the compensator maintains a constant pressure drop across the main spool – both when the load changes and when a module with a higher load pressure is actuated.

Besides independent flow the other advantage of post-compensated work sections is the ability to control multifunction operation when flow demand exceeds pump capacity. This means that all work sections will continue to function regardless of differences in their load and regardless of the pump flow. The flow relationships specified between functions will be maintained over the full flow range of the pump.

The shock valves PVLP with fixed setting and the suction valves PVLA on ports A and B are used for the protection of the individual working function against overload and/or cavitation.

**PVG 100 VALVE GROUP  
WITH CLOSED CENTER  
PVPV**

In load sensing systems the load pressure is led to the pump regulator via the LS connection. In the neutral position the pump control sets the displacement so that leakage in the system is compensated for, to maintain the set stand-by pressure.

When a main spool is actuated the pump regulator will adjust the displacement so that the set differential pressure between P and LS is maintained.

The pressure relief valve in PVP should be set at a pressure of approx. 30 bar [435 psi] above maximum system pressure (set on the pump or external pressure relief valve).

---

With post-compensated valves, the rating of the A- and B work-port flow will depend on the pressure drop across the main spool PVBS. In open center systems, this pressure drop (standby-pressure) is generated by the volume of pump flow led to tank across the pressure adjusting spool in the inlet PVPF. Since the pressure drop varies with pump flow volume led to tank, also the A- and B work-port flow will vary (see further details page 19).

In closed center systems, the pressure drop across the main spool equals the standby setting of the pump, measured at the P-port of the valve. The A and B work port flow will remain unchanged as long as the standby is unchanged.

---

**PVG 100  
 SECTIONAL DRAWING  
 PVP WITH INTEGRATED  
 PRIORITY VALVE**

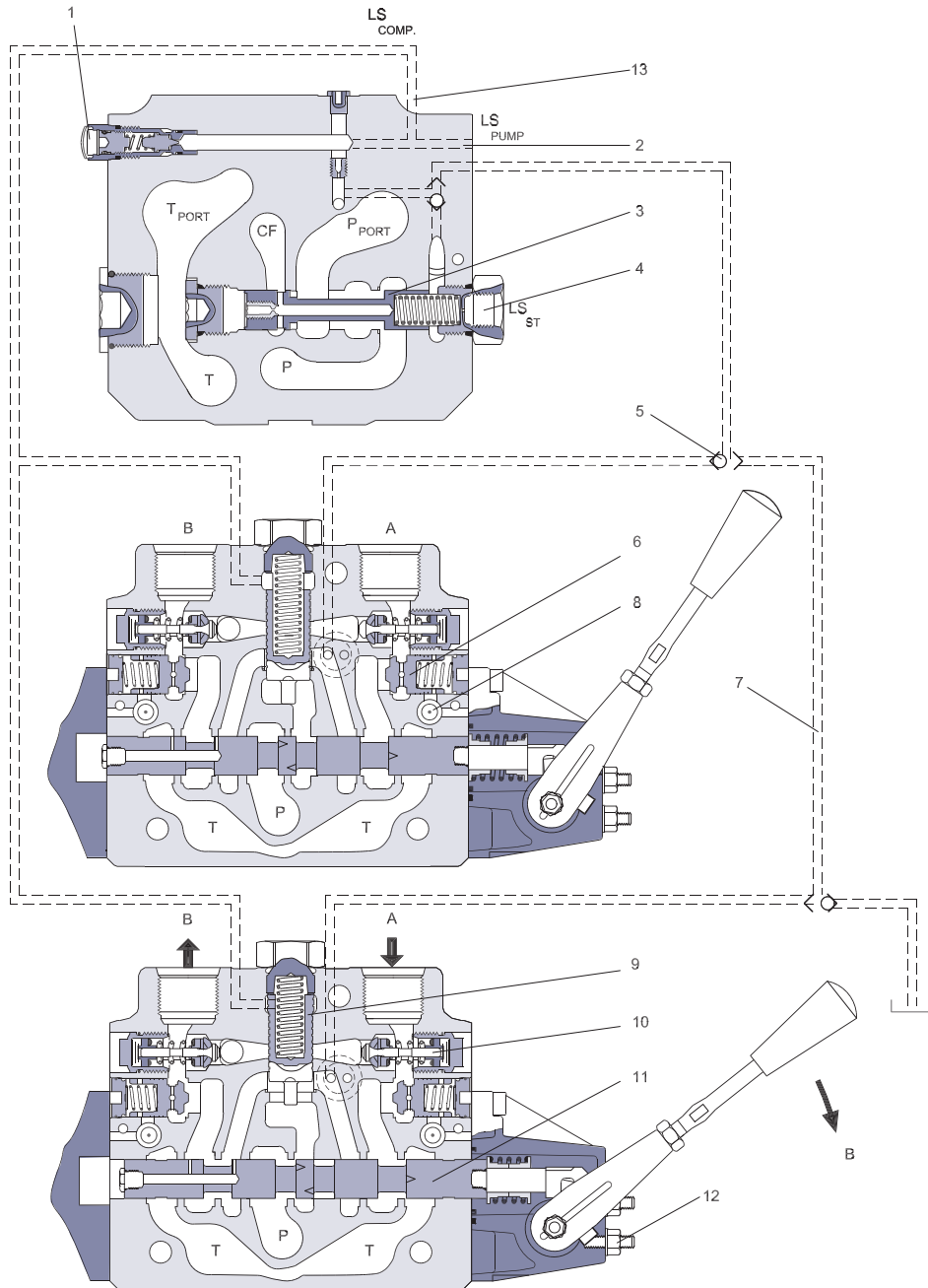

157-670.10..10

- |                                    |   |
|------------------------------------|---|
| 1. LS relief valve                 | 8. Logic cartridge for POC                            |
| 2. LS connection                   | 9. Pressure compensator                               |
| 3. Priority spool for CF           | 10. Shock and suction valve, PVLP                     |
| 4. LS connection for steering unit | 11. Main spool, PVBS                                  |
| 5. Shuttle valve                   | 12. Max. oil flow adjustment screws for ports A and B |
| 6. Pilot operated check valve, POC |   |
| 7. LS line                         |   |

**PVG 100  
 VALVE GROUP**

The technical data for PVG 100 are typical measured results. For the hydraulic system a mineral based hydraulic oil with a viscosity of 21 mm<sup>2</sup>/s [102 SUS] and a temperature of 50°C [122°F] was used.

Max. pressure	Port P continuous	350 bar	[5075 psi]
	Port A/B	350 bar	[5075 psi]
	Port T, static / dynamic	25 bar/40 bar	[365/580 psi]
	Port T0, static / dynamic	5 bar/10 bar	[75/145 psi]
Oil flow, rated (See characteristics, see page 20)	Port P*	250 l/min	[66 US gal/min]
	Port A/B, with press. comp.	180 l/min	[47.6 US gal/min]
Spool travel, standard		± 7 mm	[±0.28 in]
Spool travel, float position spool P→B→F	Proportional range	5.5 mm	[±0.22 in]
	Float position	8 mm	[±0.32 in]
Dead band, flow control spools	Standard	± 1.5 mm	[±0.06 in]
Max. spool leakage at 100 bar [1450 psi] and 21 mm <sup>2</sup> /s [102 SUS]	A/B → T, without shock valve	20 cm <sup>3</sup> /min	[1.85 in <sup>3</sup> /min]
	A/B → T, with shock valve	25 cm <sup>3</sup> /min	[2.15 in <sup>3</sup> /min]
Max. internal leakage with pilot operated check valve at 200 bar [2900 psi] and 21 mm <sup>2</sup> /s [102 SUS]	A/B → T, without shock valve	1 cm <sup>3</sup> /min	[0.06 in <sup>3</sup> /min]
	A/B → T, with shock valve	6 cm <sup>3</sup> /min	[0.37 in <sup>3</sup> /min]
Oil temperature (inlet temperature)	Recommended temperature	30 → 60°C	[86 → 140°F]
	Min. temperature	-30°C	[-22°F]
	Max. temperature	+90°C	[194°F]
Ambient temperature		-30 → +60°C	[-22 → +140°F]
Oil viscosity	Operating range	12 - 75 mm <sup>2</sup> /s	[65 - 347 SUS]
	Min. viscosity	4 mm <sup>2</sup> /s	[39 SUS]
	Max. viscosity	460 mm <sup>2</sup> /s	[2128 SUS]
Filtration (See page 29)	Max. contamination (ISO 4406)	23/19/16	23/19/16

\* see also page 10 and 11

**PVH,  
 HYDRAULIC ACTUATION**

Regulation range	5-15 bar	[75-220 psi]
Max. pilot pressure	30 bar	[435 psi]
Max. pressure on port T 1)	10 bar	[145 psi]

<sup>1)</sup> The PVRHH remote control (hydraulic joystick) lever should be connected direct to tank.

**PVM,  
 MECHANICAL ACTUATION**

Regulation range, control lever stander spool		Proportional range	±19.5°	
Regulation range, float		Proportional range	±15.3°	
		Float position	22.3°	
Operating force			Neutral position	Max. spool travel
		PVM + PVMD	22 ± 3 N•m [5.0 ± 0.7 lbf-in]	28 ± 3 N•m [6.3 ± 0.7 lbf-in]
		PVM + PVE <sup>1)</sup>	22 ± 3 N•m [5.0 ± 0.7 lbf-in]	28 ± 3 N•m [6.3 ± 0.7 lbf-in]
		PVM + PVH	27 ± 3 N•m [6.0 ± 0.7 lbf-in]	83 ± 3 N•m [18.7 ± 0.7 lbf-in]
Operating force	PVM + PVMR	Spool displacement from neutral position		26 Nm [230 lbf-in]
		Spool displacement from any other position		16.5 Nm [146 lbf-in]
	PVM + PVMF	Spool displacement from neutral position		22 Nm [5.0 lbf-in]
		Spool displacement into float position		60 Nm [13.5 lbf-in]
		Spool displacement away from float position		28 Nm [6.3 lbf-in]
Control lever positions		No.	2 × 6	

<sup>1)</sup>PVE without voltage

**PVE,  
 REACTION TIME**

Voltage	Function		PVEO	PVEA	PVEH	PVES
			ON/OFF	Prop.	Prop.	Prop.
			s	fine	high	super
			s	s	s	s
Neutral switch	Reaction time from neutral position to max. spool travel	Max.	0.235	0.500	0.230	0.230
		Rated	0.180	0.320	0.150	0.150
		Min.	0.120	0.250	0.120	0.120
Neutral switch	Reaction time from max. spool travel to neutral position	Max.	0.175	0.550	0.175	0.175
		Rated	0.090	0.400	0.090	0.090
		Min.	0.065	0.300	0.065	0.065
Constant voltage	Reaction time from neutral position to max. spool travel	Max.	–	0.500	0.200	0.200
		Rated	–	0.320	0.120	0.120
		Min.	–	0.250	0.050	0.050
Constant voltage	Reaction time from max. spool travel to neutral position	Max.	–	0.250	0.100	0.100
		Rated	–	0.200	0.090	0.090
		Min.	–	0.150	0.065	0.065
Hysteresis <sup>1)</sup>	rated		-	2%	4%	<1%

<sup>1)</sup> Hysteresis is indicated at rated voltage and f = 0.02 Hz for one cycle. A cycle incl. N > full A > N > full B > N.



**PVE,  
 OIL CONSUMPTION AND HYSTERESIS**

Voltage	Function		PVEO ON/OFF	PVEA Prop. fine	PVEH Prop. high	PVES Prop. super
Without voltage	Pilot oil flow per PVE	Neutral	0 l/min [0 US gal/min]	0 l/min [0 US gal/min]	0 l/min [0 US gal/min]	0 l/min [0.106 US gal/min]
With voltage	Pilot oil flow per PVE	Locked	0.1 l/min [0.026 US gal/min]	0.5 l/min [0.132 US gal/min]	0.1 l/min [0.026 US gal/min]	0.2 l/min [0.053 US gal/min]
		1 actuation	0.002 l [0.053 US gal/min]	0.002 l [0.053 US gal/min]	0.002 l [0.053 US gal/min]	0.002 l [0.053 US gal/min]
		Actuations	0.7 l/min [0.185 US gal/min]	0.75 l/min [0.200 US gal/min]	1.1 l/min [0.290 US gal/min]	1.1 l/min [0.2906 US gal/min]

**PVEO**

		PVEO	
Supply voltage $U_{DC}$	rated	12 V DC	24 V DC
	range	11 V to 15 V	22 V to 30 V
	max. ripple	5%	
Current consumption at rated voltage		0.65 A @ 12 V	0.33 A @ 24 V
Input impedance in relation to $0.5 \cdot U_{DC}$		12 K $\Omega$	
Power consumption		8 W	

**PVEA, PVEH AND PVES**

		PVEA, PVEH and PVES	
Supply voltage $U_{DC}$	rated	11 V to 32 V	
	range	11 V to 32 V	
	max. ripple	5%	
Current consumption at rated voltage	PVEH/PVES (PVEA)	0.57 (0.28) A @ 12 V	0.3 (0.15) A @ 24 V
Signal voltage	neutral	$0.5 \cdot U_{DC}$	
	A-port $\leftrightarrow$ B-port	$0.25 \cdot U_{DC}$ to $0.75 \cdot U_{DC}$	
Signal current at rated voltage		0.25 mA to 0.70 mA	
Input impedance in relation to $0.5 \cdot U_{DC}$		12 K $\Omega$	
Input capacitor		100 nF	
Power consumption	PVEH/PVES (PVEA)	7 (3.5) W	

For detailed information, see PVE actuator catalog, 520L0553

**PVP 100 INLET MODULES**

Symbol	Description PVPF	Port size	Code number	
<p>157-697.11</p>	<p>Open center pump side module for pumps with fixed displacement            Max. pump flow 250 l/min [66 US gal/min]</p> <p>With pilot supply for electrical actuation            With pilot gauge port</p>	12 bar spring*	161B5110	
		20 bar spring*	161B5112	
		1 5/16-12 UN	12 bar spring*	161B5510
			20 bar spring*	161B5512
<p>157-684.11</p>	<p>Open center pump side module for pumps with fixed displacement            Max. pump flow 250 l/min [66 US gal/min]</p> <p>With pilot supply for electrical actuation            With pilot gauge port            Accumulator port and facility for pilot shut off.</p>	12 bar spring*	161B5140	
		20 bar spring*	161B5142	
		1 5/16-12 UN	12 bar spring*	161B5540
			20 bar spring*	161B5542
Symbol	Description PVPV	Port size	Code number	
<p>157-685.11</p>	<p>Closed center pump side module for pumps with variable displacement            Max. pump flow 250 l/min [66 US gal/min]</p> <p>With pilot supply for electrical actuation            With pilot gauge port</p>	G1	161B5111	
		1 5/16-12 UN	161B5511	
<p>157-698.11</p>	<p>Closed center pump side module for pumps with variable displacement            Max. pump flow 250 l/min [66 US gal/min]</p> <p>With pilot supply for electrical actuation            With pilot gauge port            Accumulator port and facility for pilot shut off.</p>	G1	161B5141	
		1 5/16-12 UN	161B5541	
<p>157-686.11</p>	<p>Closed center pump side module for pumps with variable displacement            Max. pump flow 200 l/min [52.8 US gal/min]            With integrated priority function            Max. CF-flow 60 l/min [15.9 US gal/min]            With pilot supply for electrical actuation</p>	P = G <sup>3</sup> / <sub>4</sub> T = G 1	161B5211	
		P = 1 1/16-12 U T = 1 5/16-12 UN	161B5611	

\* Spring for pressure matching spool - PVPF open center only. For further details see page 19.

**PVP 100 ACCESSORIES FOR PUMP SIDE MODULES**

Symbol	Description	Code number	
	Dummy spool	155G5041*	
<p>157-683.10</p>	PVPE electrically actuated unloading valve. Normally open solenoid valve	12 V	155G5052*
		24 V	155G5054*
<p>157-706.10</p>	PVPP electrically actuated pilot shut off. Normally closed solenoid valve	12 V	800572719
		24 V	800572819

\* For PVPF open center inlets only

**PVB 100 BASIC MODULE**

Symbol	Description PVB	Port size	Code number	
			Without PVLP	With PVLP
<p>157-597.11</p>	Post compensated	G 3/4	161B6250	161B6260
		1 1/16 - 12 UN	161B6650	161B6660
<p>157-596.11</p>	Post compensated With pilot operated check valves on work port A and B	G 3/4	161B6252	161B6262
		1 1/16 - 12 UN	161B6652	161B6662

**PVB 32 BASIC MODULE WITH T0**

Symbol	Description PVB	Code number 157B.....			
		No facility for shock valve		Facility for shock valve	
		BSP	SAE	BSP	SAE
<p>157-591.11</p>	<p>Without load drop check valve and pressure compensator.</p> <p>Can be used where load holding valves prevent oil from floating back through the channel P.</p>	6010	6410	-	-
<p>157-592.11</p>	<p>Load drop check valve</p>	6110	6909	6140	6904
<p>157-593.11</p>	<p>Pre compensated</p>	6210	6922	6240	6906
<p>157-594.10</p>	<p>Pre compensated</p> <p>Adjustable LS A/B limiting valves.</p> <p>External LS connection port A/B.</p> <p>Also used for float position spools.</p>	6213	6613	6243	6643

Connection: A and B-port G 1/2 [7/8 in - 14]

**PVBZ 32 BASIC MODULE**

Symbol	Description PVBZ	Without thermal relief valve 157B...		With thermal relief valve 157B...	
		BSP	SAE	BSP	SAE
	Without compensator and load drop check valve With pilot operated check valves on work port B Max. work port pressure = 210 bar [3045 psi]	6051	6451	-	-
	Without compensator and load drop check valve With pilot operated check valves on work port A and B Max. work port pressure = 210 bar [3045 psi]	6052	6452	-	-
	Pre compensated With pilot operated check valves on work port B Compensated work port flow A/B = 100 l/min [26.4 US gal/min] Max. work port pressure = 210 bar [3045 psi]	6251	6651	6261	6661
	Pre compensated With pilot operated check valves on work port A and B Compensated work port flow A/B = 100 l/min [26.4 US gal/min] Max. work port pressure = 210 bar [3045 psi]	6252	6652	6262	6662
	Pre compensated With pilot operated check valves on work port A and B LSA/B shuttle valve for float and shuttle pin Compensated work port flow A/B = 100 l/min [26.4 US gal/min] Max. work port pressure = 210 bar [3045 psi]	-	-	6266	6666

Connection: A and B-port G 1/2 [7/8in - 14]  
 Seal kit for PVBZ 157B6989

**CODE NUMBERS FOR USE  
 ON PVG 100  
 157B....**

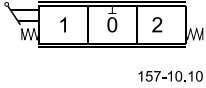

PVM Mechanical actuation	Code number	
	w. stopscrews	w/o stop screws
PVM, Standard, spring centered	22.5° 157B3171	157B3191
Individual oil flow adjustment to ports A an B	37.5° 157B3172	157B3192
PVM Without actuation lever and base. Shaft for mounting of actuation lever.	157B3173	157B3193
PVM A standard, without actuation lever.	22.5° 157B3175	157B3195
With base for mounting of actuation lever.	37.5° 157B3174	157B3194

Code number for the anodized version of 157B3171 is 157B3184

PVMD Cover for mechanical actuation	Code number
PVMD* Cover for purely mechanically operated valve	157B0001

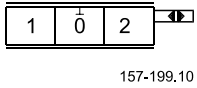

PVH Hydraulic actuation	Code number
PVH*	G 1/4 157B0008
Cover for hydraulic remote control	9/16-18 UNF 157B0007

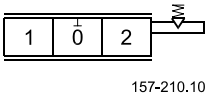

PVMR Friction detent	Code number
PVMR* Friction detent	157B0015

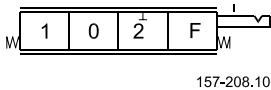

PVMF Mechanical float position	Code number
PVMF* Mechanical float position lock, float B-port	157B0005

\* Opposite of the PVM

**CODE NUMBERS FOR USE  
 ON PVG 100  
 157B....**

*PVE for PVG 100*

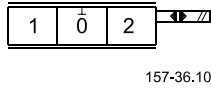

PVEO, ON/OFF actuation Code no. 157B....		Hirschmann		AMP		Deutsch	
		12 V	24 V	12 V	24 V	12 V	24 V
PVEO	ON/OFF	4216	4228	4901	4902	4291	4292
	ON/OFF with ramp	4217	4229	4903	4904	-	-

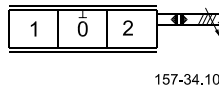
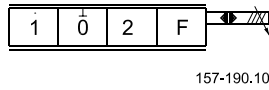
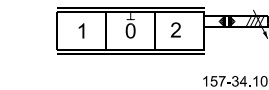
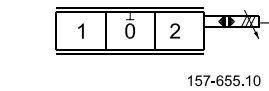

PVEA/PVEH/PVES, proportional actuation Code no. 157B....		Hirschmann connector 11 - 32 V	AMP connector 11 - 32 V	Deutsch connector 11 - 32 V
PVEA	Standard, active fault monitoring	Not available	4734	4792
	Standard, passive fault monitoring	Not available	4735	-
PVEA-DI	Standard, active fault monitoring	Not available	4736	4796
	Standard, passive fault monitoring	Not available	4737	-
PVEH	Standard, active fault monitoring	4032	4034	4092
	Standard, passive fault monitoring	4033	4035	-
PVEH-F	Float, active fault monitoring	Not available	4338	4398
PVEH-DI	Standard, active fault monitoring	Not available	4036	4096
	Standard, passive fault monitoring	Not available	4037	-
PVEP	Standard, active fault monitoring	-	-	4752
PVEP-F	Standard, active fault monitoring	-	-	4793
PVES	0% hysteresis, active fault monitoring	4832	4834	4892
	0% hysteresis, passive fault monitoring	4833	4835	-
PVED-CC	Can-bus interface	Not available	4943	4944

**PVLA, SUCTION VALVE (FITTED IN PVB)**

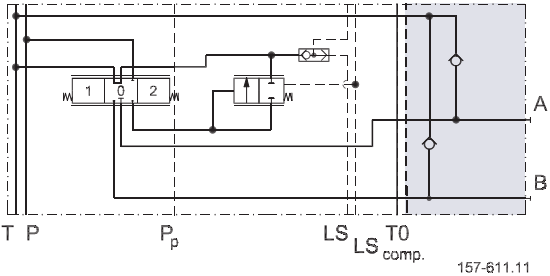
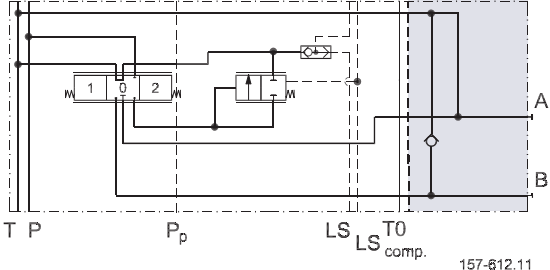
Symbol	Description	Code number
 <p>157-611.11</p>	<p>Suction valve for port A and/or B</p>	<p>157B2001</p>
 <p>157-612.11</p>	<p>Cap for connecting the nonactive port to tank, when using a single acting spool</p>	<p>157B2002</p>

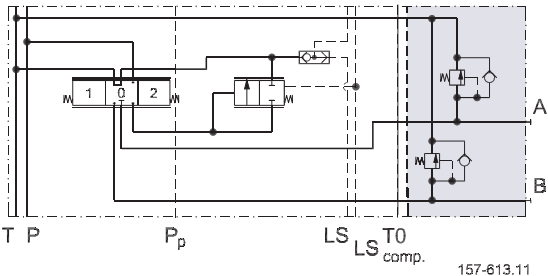

**PVLP,  
 SHOCK AND SUCTION VALVE (FITTED IN PVB)**

Symbol	Description	Setting		Code number
		bar	[psi]	
	Shock and suction valve for port A and B. (Not adjustable)	32	460	157B2032
		50	725	157B2050
		63	914	157B2063
		80	1160	157B2080
		100	1450	157B2100
		125	1813	157B2125
		140	2031	157B2140
		150	2175	157B2150
		160	2320	157B2160
		175	2538	157B2175
		190	2755	157B2190
		210	3045	157B2210
		230	3335	157B2230
		240	3480	157B2240
		250	3625	157B2250
		265	3843	157B2265
		280	4061	157B2280
300	4351	157B2300		
320	4641	157B2320		
350	5075	157B2350		

**PVT 100 TANK MODULE**

Symbol	Description	Port size	Code number
	PVT Without active elements With T-port PVLP shock valve facility	G 1 1/4  1 5/8-UN	161B2500  161B2520
	PVT Without active elements With T-port PVLP shock valve facility With LX connection G 1/4 [9/16 in - 18 UNF	G 1 1/4  1 5/8-UN	161B2505  161B2525

**PVTI 100/32 INTERFACE MODULE**

Symbol	Description	Portsize	Code number
	PVTI Without active elements With T-port PVLP shock valve facility	G 1 1/4  1 5/8-UN	161B2200  161B2220

**ASSEMBLY KIT PVG 100 PVSI / PVT**

Description	Code number 161B....							
	1 PVB	2 PVB	3 PVB	4 PVB	5 PVB	6 PVB	7 PVB	8 PVB
Tie bolts and seals	8001	8002	8003	8004	8005	8006	8007	8008

**ASSEMBLY KIT PVG 100 / PVTI INTERFACE MODULE**

Description	Code number 161B....							
	1 PVB	2 PVB	3 PVB	4 PVB	5 PVB	6 PVB	7 PVB	8 PVB
Tie bolts and seals	8021	8022	8023	8024	8025	8026	8027	8028

**ASSEMBLY KIT PVB 32**

Description	Code number 157B....									
	1 PVB	2 PVB	3 PVB	4 PVB	5 PVB	6 PVB	7 PVB	8 PVB	9 PVB	10 PVB
Tie bolts and seals	8000	8001	8002	8003	8004	8005	8006	8007	8008	8009

**GENERAL**

The characteristics in this catalog are typical measured results. During measuring a mineral based hydraulic oil with a viscosity of 21 mm<sup>2</sup>/s [102 SUS] at a temperature of 50°C [122°F] was used.

**PVP,  
 PUMP SIDE MODULE**

**Pressure relief valve characteristic in PVP**

The pressure relief valve is set at an oil flow of 15 l/min [4.0 US gal/min].

Setting range:  
 30 to 350 bar [435 to 5075 psi]

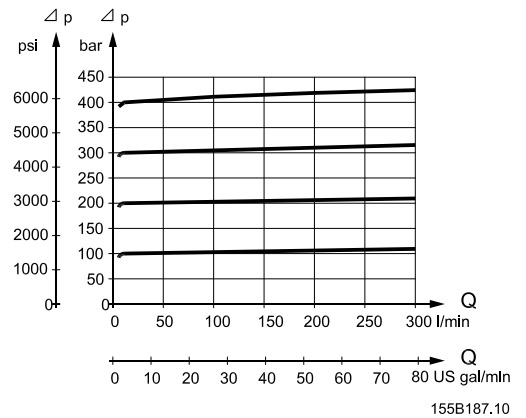

**Neutral flow pressure in PVP,  
 open center**

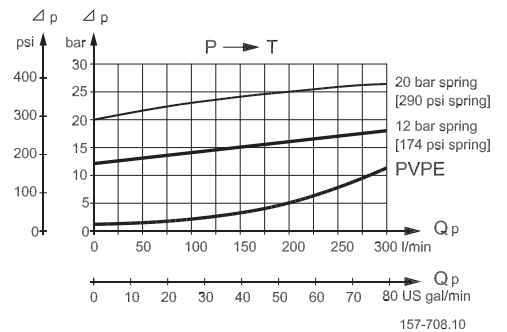

**OPEN CENTER FLOW  
 RATING**

As mentioned on page 5, the flow rating of the different main spools will depend on the standby pressure available. In open center systems, the standby pressure equals the pressure drop P->T, see above diagram. A pump flow of 150 l/min led to tank across the pressure adjusting spool, will generate a standby pressure of app. 15 bar (PVP with 12 bar spring). The according main spool flow ratings will correspond to the curves on [page 20](#)

For PVPs with a 20 bar spring, the standby pressure available will be 20 bar or higher. Hence the according main spool flow ratings will correspond to [page 20](#).

**PVB,  
 BASIC MODULE**

**PVB with pressure compensation, closed center PVP  
 Oil flow as a function of spool travel for spools A to F**

Set pressure difference between pump pressure and LS signal = 15 bar [218 psi]  
 measured at the P-port of the valve. For spool size reference see page 30 and 31.

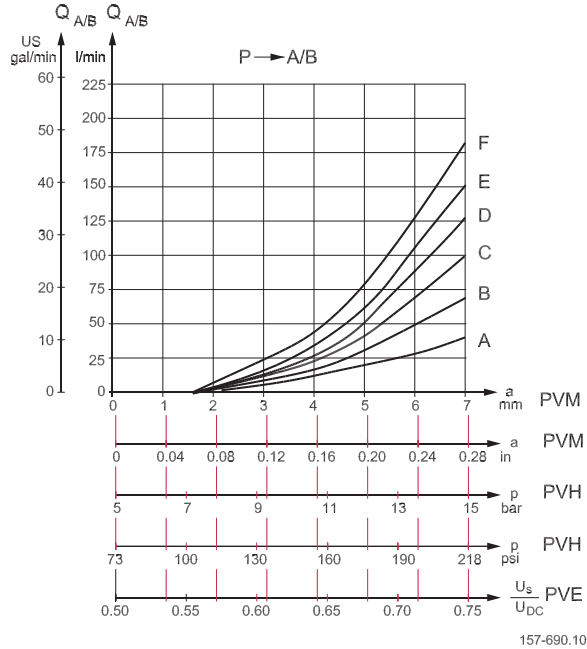

**PVB with pressure compensation, closed center PVP  
 Oil flow as a function of spool travel for spools A to F**

Set pressure difference between pump pressure and LS signal = 20 bar [290 psi]  
 measured at the P-port of the valve. For spool size reference see page 30 and 31.

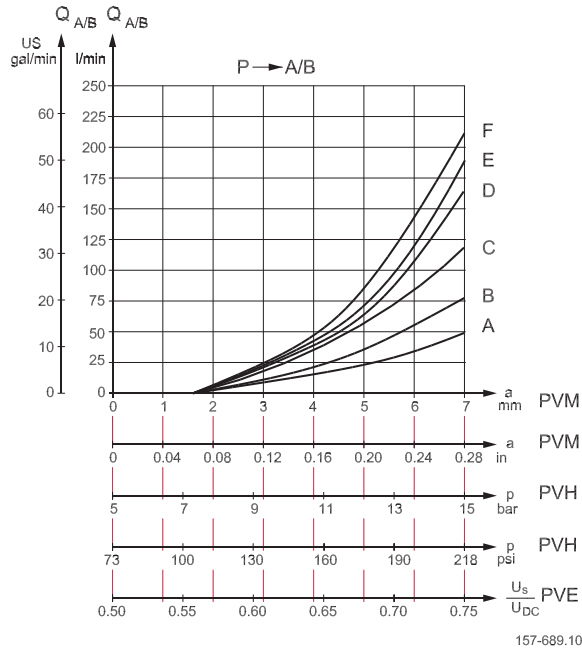

**PVB,  
BASIC MODULE  
(CONTINUED)**

**Oil flow at LS pressure limiting,  
pressure compensated PVB  
for spools A, C and E**

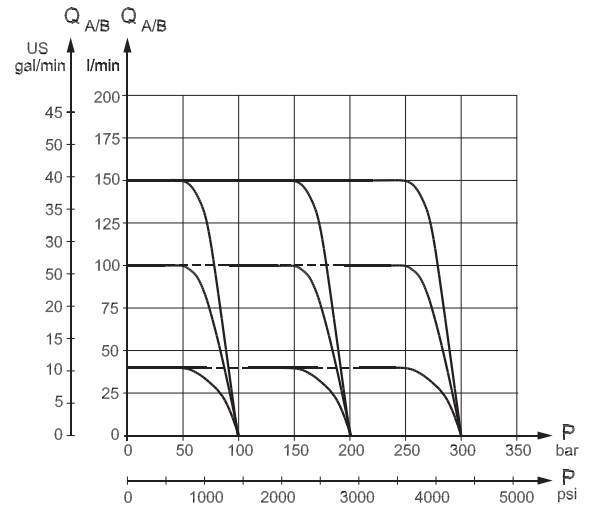

157-703.10

**Oil flow at LS pressure limiting,  
pressure compensated PVB  
for spools B, D and F**

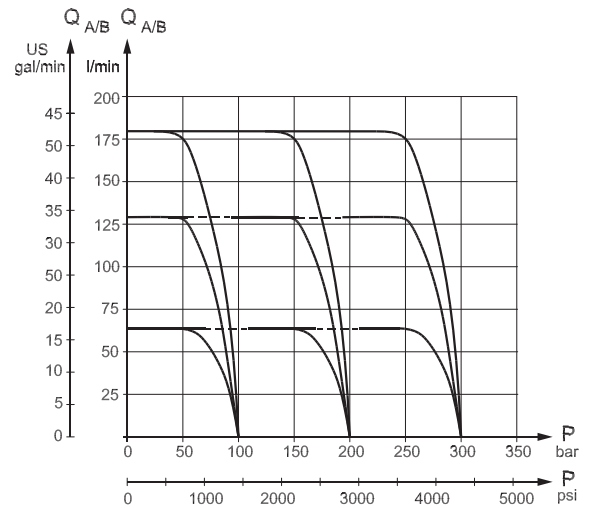

157-704.10

**PVLP,  
SHOCK AND  
SUCTION VALVE**

**PVLP, shock valve**

PVLP is set at an oil flow of 10 l/min [2.6 US gal/min].

The shock valve PVLP is designed to absorb shock effects. Consequently, it should not be used as a pressure relief valve.

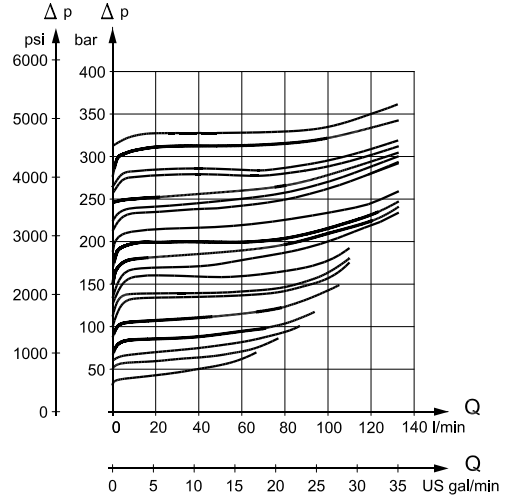

157-312.10

**PVLA,  
SUCTION VALVE**

**PVLP/PVLA, suction valve**

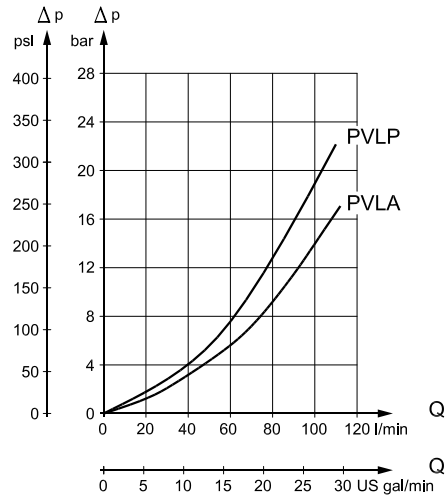

157-313.10

**VALVE DIMENSION,  
 PVG 100, OPEN CENTER  
 PVPF**

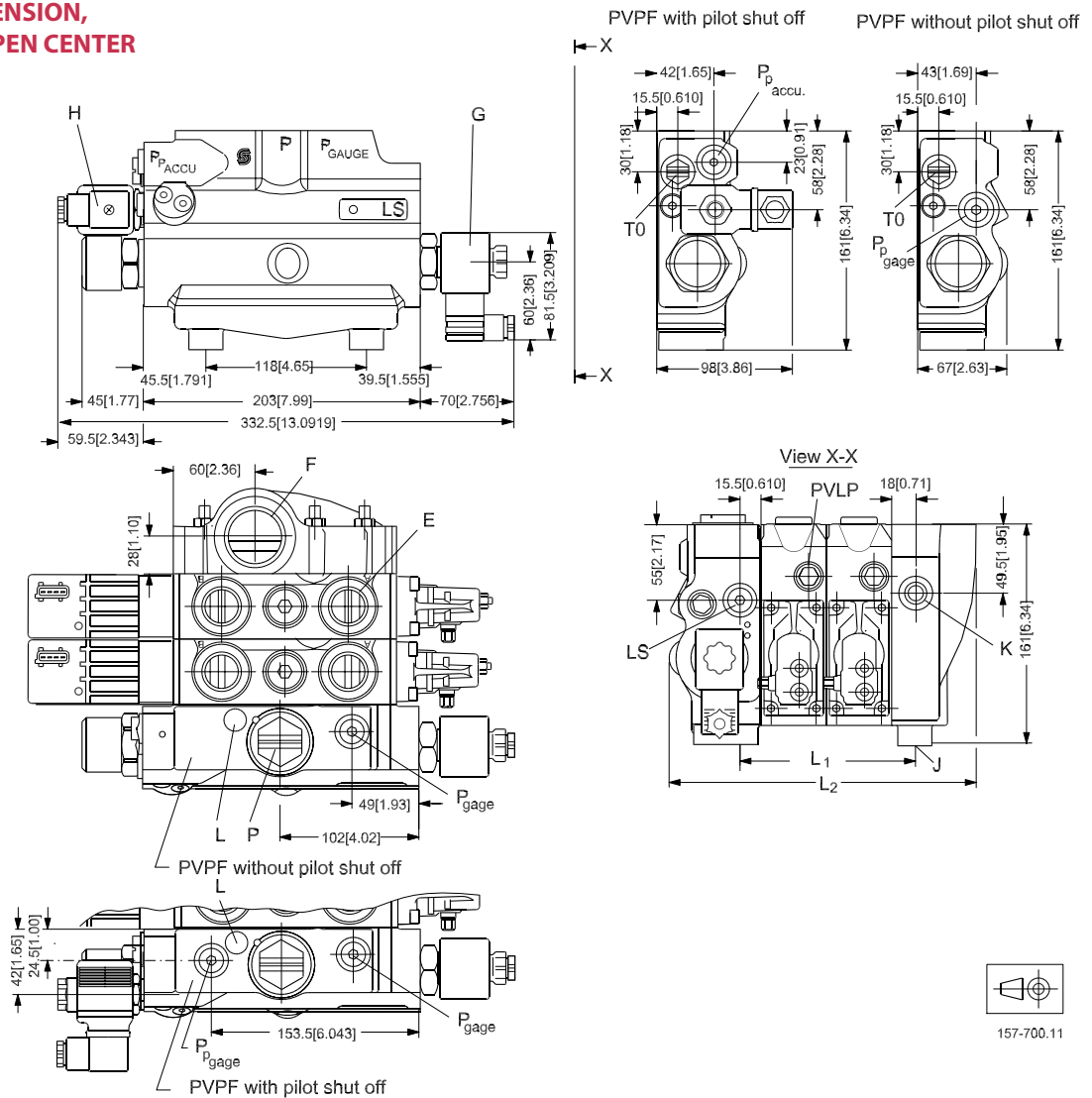

- P<sub>p</sub> accumulator connection : G<sup>1</sup>/<sub>4</sub> [9/16 in - 18 UNF]
- LS connection : G<sup>1</sup>/<sub>4</sub> [9/16 in - 18 UNF]
- P gage connection : G<sup>1</sup>/<sub>4</sub> [9/16 in - 18 UNF]
- T0 port connection : G<sup>1</sup>/<sub>4</sub> [9/16 in - 18 UNF]
- P<sub>p</sub> gage connection : G<sup>1</sup>/<sub>4</sub> [9/16 in - 18 UNF]
- P: Pump port connection; G1 [1 5/8 in - 12 UNF]

- G: PVPE unloading valve
- F : Tank port connection; G 1 1/4 [1 5/8 in - 12 UNF]
- H: PVPP pilot shut off valve
- J : Mounting thread; M12 x 14 mm deep.  
 It is recommended to only use 3 of 4 mounting holes provided.
- K : LX connection : G<sup>1</sup>/<sub>4</sub> [9/16 in - 18 UNF]
- L : LS relief valve

		1 PVB	2 PVB	3 PVB	4 PVB	5 PVB	6 PVB	7 PVB	8 PVB
L <sub>1</sub>	mm	80	128	176	224	272	320	368	416
	[in]	[3.15]	[5.04]	[6.93]	[8.82]	[10.71]	[12.60]	[14.49]	[16.38]
L <sub>2</sub>	mm	176	224	272	320	368	416	464	512
	[in]	[6.93]	[8.82]	[10.71]	[12.60]	[14.49]	[16.38]	[18.27]	[20.16]

**VALVE DIMENSION  
 PVG 100/32, CLOSED  
 CENTER PVPV**

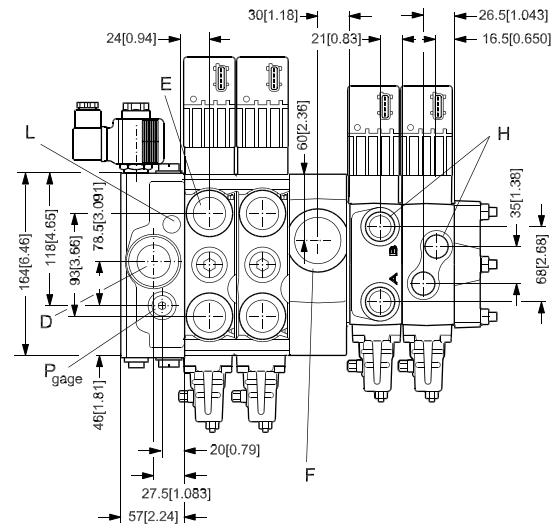
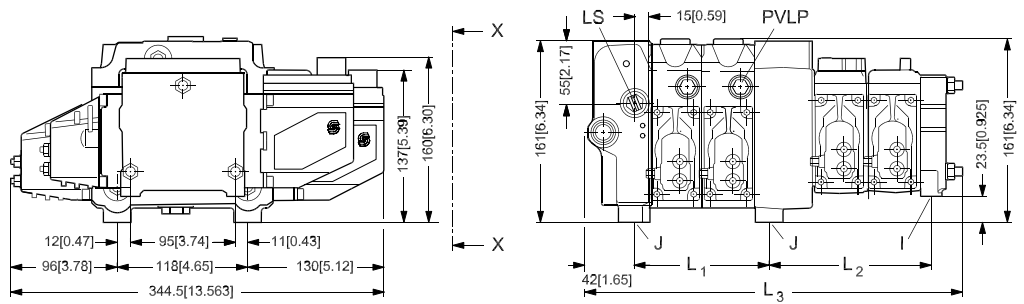

- LS connection : G<sup>1</sup>/<sub>4</sub> [9/16 in - 18 UNF]
- P gage connection : G<sup>1</sup>/<sub>4</sub> [9/16 in - 18 UNF]
- T0 port connection : G<sup>1</sup>/<sub>4</sub> [9/16 in - 18 UNF]
- Pp gage connection : G<sup>1</sup>/<sub>4</sub> [9/16 in - 18 UNF]
- Pp accumulator connection : G<sup>1</sup>/<sub>4</sub> [9/16 in - 18 UNF]
- D : Pump port connection; G1 [1 5/16 in - 12 UNF]
- E : Port A and B PVB 100; G<sup>3</sup>/<sub>4</sub> [1 1/16 in - 12 UNF]
- F : Tank port connection; G1 1/4 [1 5/8 in - 12 UNF]
- H : Port A and B PVB 32; G<sup>1</sup>/<sub>2</sub> [7/8 in - 14 UNF]
- I : Mounting thread ; M8 x 15 mm deep [5/16 in - 18 UNC]
- J : Mounting thread; M12 x 14 mm deep
- L : LS relief valve

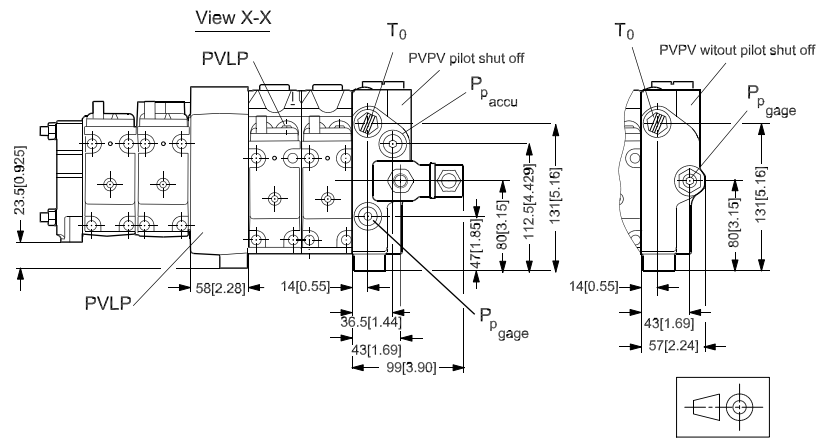

157-701.14

	1 PVB	2 PVB	3 PVB	4 PVB	5 PVB	6 PVB	7 PVB	8 PVB	9 PVB	10 PVB	
L <sub>1</sub>	mm	80	128	176	224	272	320	368	416	-	-
	[in]	[3.15]	[5.04]	[6.93]	[8.82]	[10.71]	[12.60]	[14.49]	[16..38]	-	-
L <sub>2</sub>	mm	100	148	196	244	292	340	388	436	484	532
	[in]	[3.94]	[5.83]	[7.72]	[9.61]	[11.50]	[13.39]	[15.28]	[17.16]	[19.05]	[20.94]
L <sub>3</sub>	mm	-	245	293	341	389	437	485	533	581	629
	[in]	-	[9.64]	[11.54]	[13.43]	[15.31]	[17.20]	[19.09]	[20.98]	[22.87]	[24.76]

It is recommended not to exceed 10 PVB 100/32 in a valve group.



**VALVE DIMENSION  
 PVG 100, CLOSED  
 CENTER PVP WITH  
 INTEGRATED PRIORITY  
 VALVE**

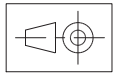
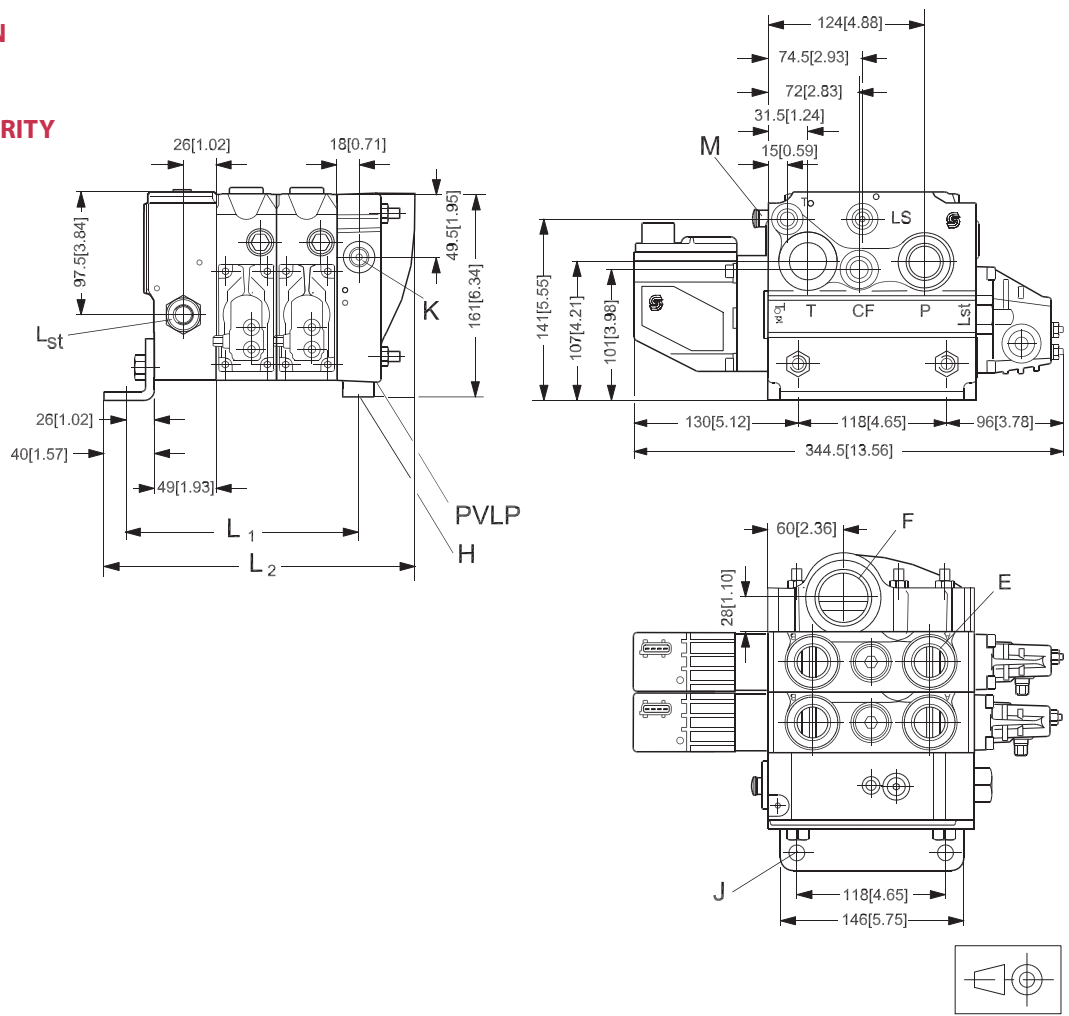

157-705.12

- CF connection : G<sup>1</sup>/<sub>2</sub> [3/4 in - 16 UNF]
- LS connection : G<sup>1</sup>/<sub>4</sub> [9/16 in - 18 UNF]
- P gage connection : G<sup>1</sup>/<sub>4</sub> [7/16 in - 24 UNF]
- T0 port connection : G<sup>1</sup>/<sub>4</sub> [9/16 in - 18 UNF]
- Pp gage connection : G<sup>1</sup>/<sub>4</sub> [7/16 in - 24 UNF]
- P pump port connection; G<sup>3</sup>/<sub>4</sub> [1 1/16 in - 12 UNF]
- Lst: LS connection for steering unit; G<sup>1</sup>/<sub>4</sub> [9/16 in - 18 UNF]
- E : Port A and B PVB 100; G<sup>3</sup>/<sub>4</sub> [1 1/16 in - 12 UNF]
- H : Mounting thread : M12 x 14 mm deep
- J : Mounting bracket with holes for M12 screws
- K : LX connection : G<sup>1</sup>/<sub>4</sub> [9/16 in - 18 UNF]
- M : LS relief valve
- F : G<sup>1</sup>/<sub>4</sub> [1 1/16 in]

		1 PVB	2 PVB	3 PVB	4 PVB	5 PVB	6 PVB	7 PVB	8 PVB
L <sub>1</sub>	mm	140	188	236	284	332	380	428	476
	[in]	[5.51]	[5.12]	[9.29]	[11.18]	[9.13]	[14.96]	[16.85]	[18.74]
L <sub>2</sub>	mm	198	246	294	342	390	438	486	534
	[in]	[7.80]	[9.69]	[11.57]	[13.46]	[15.35]	[17.24]	[19.13]	[21.02]

**GENERAL DIMENSIONS**

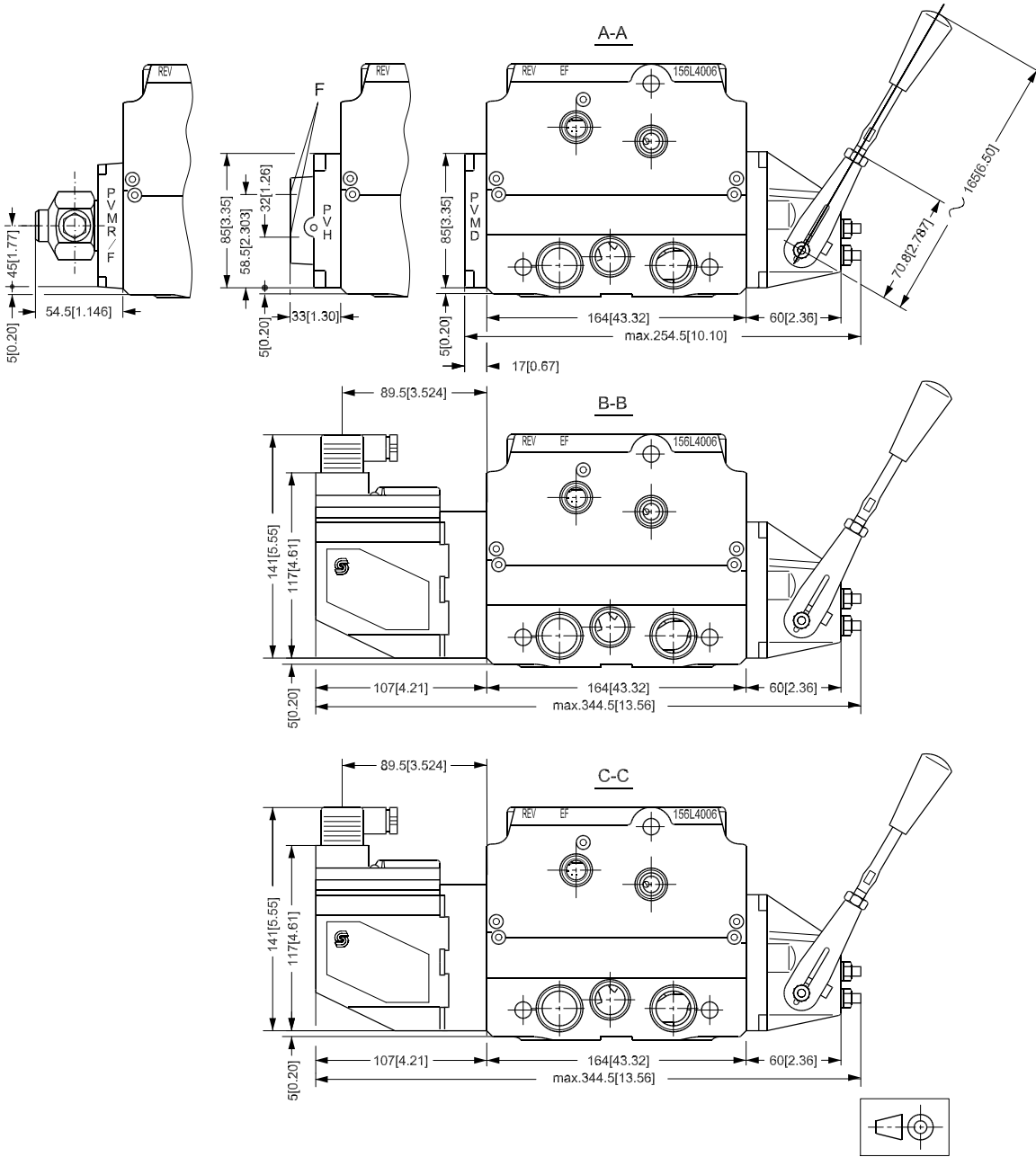

**ELECTRICALLY ACTUATED PVG 100 VARIABLE DISPLACEMENT PUMP  
 PVB 100 WITH INTEGRATED PILOT OPERATED CHECK VALVES**

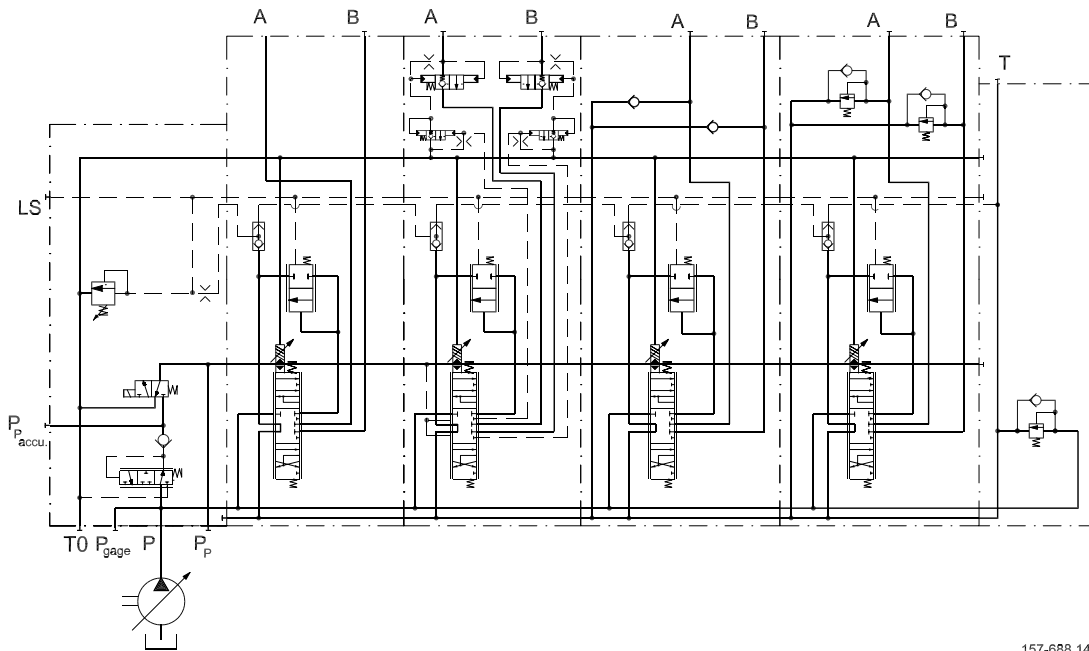

157-688.14

**ELECTRICALLY ACTUATED PVG 100/32 FIXED DISPLACEMENT PUMP  
 PVB 100/32 WITH INTEGRATED PILOT OPERATED CHECK VALVES**

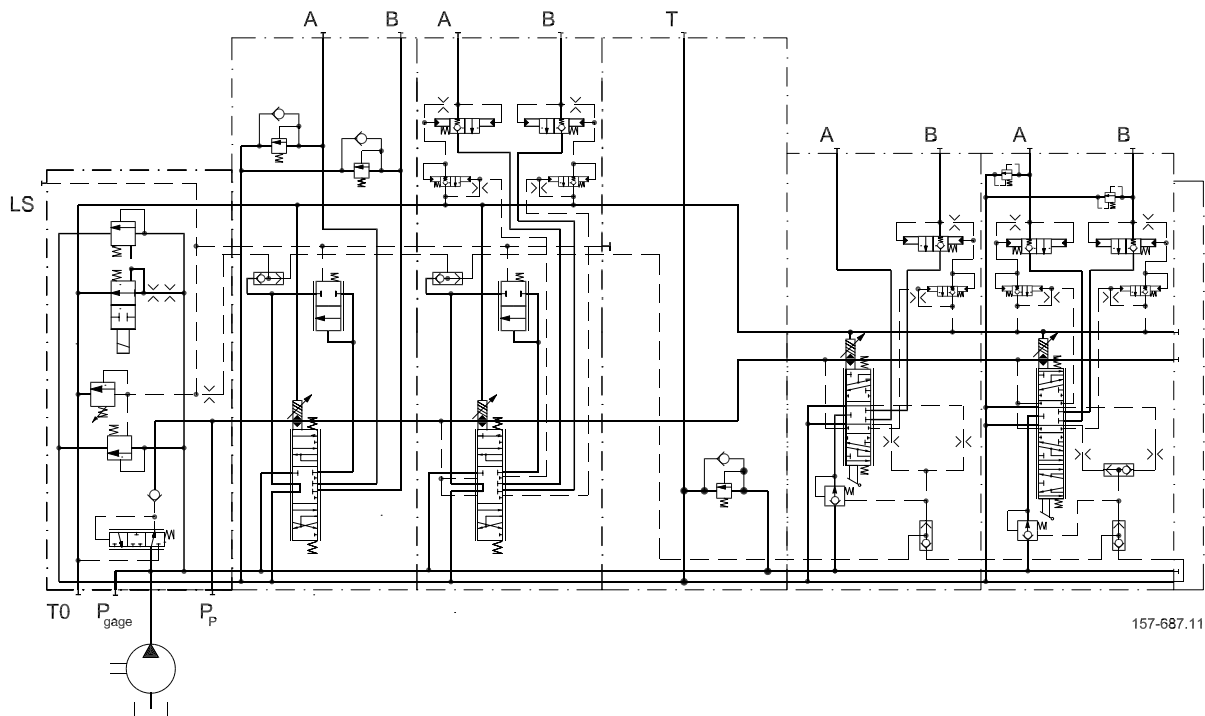

157-687.11

**OIL**

The main duty of the oil in a hydraulic system is to transfer energy; but it must also lubricate the moving parts in hydraulic components, protect them against corrosion, and transport dirt particles and heat out of the system. It is therefore important to choose the correct oil with the correct additives. This gives normal operation and long working life.

**Mineral oil**

For systems with PVG 100 valves Sauer-Danfoss recommends the use of mineral-based hydraulic oil containing additives: Type HLP (DIN 51524) or HM (ISO 6743/4).

**Non-flammable fluids**

Phosphate-esters (HFDR fluids) can be used without special precautions. However, dynamic seals must be replaced with FPM (Viton) seals.

So please contact the Sauer-Danfoss Sales Organization if the PVG 100 valve is to be used with phosphate-esters.

The following fluids should only be used according to agreement with the Sales Organization for Sauer-Danfoss:

- Water-glycol mixtures (HFC fluids)
- Water-oil emulsions (HFB fluids)
- Oil-water emulsions (HFAE fluids)

**Biodegradable oils**

PVG 100 valves can be used in systems with rapeseed oil. The use of rapeseed oil is conditioned by

- complying with the demands on viscosity, water content, temperature and filtering etc. (*see chapters below and technical data page 7*).
- adapting the operating conditions to the directions of the oil supplier.

Before using other biodegradable fluids, please consult the Sauer-Danfoss Organization.

**PARTICLE CONTENT,  
DEGREE OF  
CONTAMINATION**

Oil filtration must prevent particle content from exceeding an acceptable level, i.e. an acceptable degree of contamination.

Maximum contamination for PVG 100 is 23/19/16 (*see ISO 4406. Calibration in accordance with the ACFTD method*).

In our experience a degree of contamination of 23/19/16 can be maintained by using a filter fineness as described in the next section.

**FILTRATION**

Effective filtration is the most important precondition in ensuring that a hydraulic system performs reliably and has a long working life. Filter manufacturers issue instructions and recommendations. It is advisable to follow them.

**System filters**

Where demands on safety and reliability are very high a pressure filter with bypass and indicator is recommended. Experience shows that a 10 µm nominal filter (or finer) or a 20 µm absolute filter (or finer) is suitable.

It is our experience that a return filter is adequate in a purely mechanically operated valve system.

The fineness of a pressure filter must be selected as described by the filter manufacturer so that a particle level of 23/19/16 is not exceeded.

The filter must be fitted with pressure gauge or dirt indicator to make it possible to check the condition of the filter.

In systems with differential cylinders or accumulators the return filter must be sized to suit the max. return oil flow. Pressure filters must be fitted to suit max. pump oil flow.

**Internal filters**

The filters built into PVG 100 are not intended to filter the system but to protect important components against large particles. Such particles can appear in the system as a result of pump damage, hose fracture, use of quick-couplings, filter damage, starting up, contamination, etc.

The filter in the electrical actuator PVE protecting the solenoid valves has a mesh of 150 µm.

Bursting pressure drop for internal filters is 25 bar [360 psi].

**STANDARD SPOOLS (ELECTRICAL AND MECHANICAL ACTUATION)**

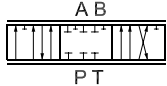
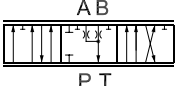
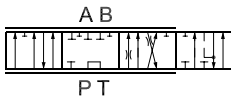
Code number 161B....	Pressure compensated flow l/min [US gal/min]					
	A 40 [10,6]	B 65 [17,2]	C 100 [26,4]	D 130 [34,4]	E 150 [39,6]	F 180 [47,6]
 A B P T 157-608.11 4-way, 3-position Closed neutral position	7022	7023	7024	7025	7026	7027
 A B P T 157-614.11 4-way, 3-position Throttled, open neutral position	7122	7123	7124	7125	7126	7127
 A B P T 4-way, 4-position Closed neutral position Float P→B→F	7622	7623	7624	7625	7626	7627

Main spools for PVG 32, see [catalog, 520L0344](#)

**STANDARD SPOOLS (HYDRAULIC ACTUATION)**

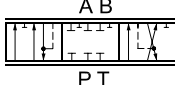
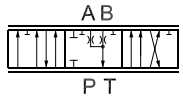
Code number 161B....	Pressure compensated flow l/min [US gal/min]					
	A 40 [10,6]	B 65 [17,2]	C 100 [26,4]	D 130 [34,4]	E 150 [39,6]	F 180 [47,6]
 A B P T 157-608.10 4-way, 3-position Closed neutral position	9522	9523	9524	9525	9526	9527
 A B P T 4-way, 3-position Throttled, open neutral position	9622	9623	9624	9625	9626	9627

**SPOOLS FOR FRICTION DETENT PVMR**

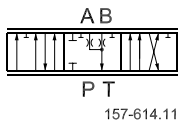
Code number 161B....	Pressure compensated flow l/min [US gal/min]					
	A 40 [10,6]	B 65 [17,2]	C 100 [26,4]	D 130 [34,4]	E 150 [39,6]	F 180 [47,6]
 <p>157-614.11</p> <p>4-way, 3-position Throttled, open neutral position</p>	9732	9733	9734	9735	9736	9737

PVMR friction detent is designed for motor spools only.

**SPOOLS FOR MECHANICAL FLOAT POSITION PVMF**

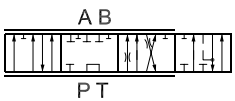
Code number 161B....	Pressure compensated flow l/min [US gal/min]					
	A 40 [10,6]	B 65 [17,2]	C 100 [26,4]	D 130 [34,4]	E 150 [39,6]	F 180 [47,6]
 <p>157-707.11</p> <p>4-way, 4-position Closed neutral position Float P → B → F</p>	9822	9823	9824	9825	9826	9827

Spools for PVB 32, see *catalog DKMH.570.C4.02*. **520L0344**  
 Spools for PVBZ 32, see *Tech Note DKMH.PN.570.N2.02* **520L0721**

*PVB, basic module*

Code no. 161B...	No facilities for shock valves A and B		Facilities for shock valves A and B	
	G 3/4	1 1/16 in-14	G 3/4	1 1/16 in-14
Without pilot operated check valve	6250	6650	6260	6660
With pilot operated check valve	6252	6652	6262	6662
Weight kg [lb]	5.5 kg [12.13 lb]			

*PVM, mechanical actuation*

Code no. 157B...	With stop screw	Without stop screw	
Standard	3171*	3191	22.5°
	3172	3192	37.5°
Standard, with base, without arm and button	3174	3194	37.5°
	3175	3195	22.5°
Standard, without base, arm and button	3173	3193	-
Weight kg [lb]	0.4 [0.9]		

\* Anodized 157B3184

*PVPC (for details see catalog, 520L0344)*

Code no. 157B...	G 1/4	9/16 in - 18 UNF	Weight	
			kg	[lb]
External pilot supply	5400	5425	0.05	0.1
External pilot supply incl. check valve	5600	5625	0.05	0.1

Not available for PVPV 157B5211 and 157B5611

*PVTI 100/32 interface module*

Code no. 161B...	BSP	SAE	Weight	
			kg	[lb]
PVTI, with T-port and PVLP facility	2200	2220	8.7	[19.18]

T-connection G 1 1/4 [1 5/8 UN]

*Tank module, PVT*

Code no. 161B...	BSP	SAE	Weight	
			kg	[lb]
PVT, with T-port and PVLP facility	2500	2520	6.3 kg	[13.89]
PVT, with LX connection, T-port and PVLP facility	2505	2525		

T-connection G 1 1/4 [1 5/8 UN]

*Assembly kit PVG 100 / PVSI / PVPT*

Description	Code number 161B....							
	1 PVB	2 PVB	3 PVB	4 PVB	5 PVB	6 PVB	7 PVB	8 PVB
Tie bolts and seals	8001	8002	8003	8004	8005	8006	8007	8008

*Assembly kit PVG 100 / PVTI interface module*

Description	Code number 161B....							
	1 PVB	2 PVB	3 PVB	4 PVB	5 PVB	6 PVB	7 PVB	8 PVB
Tie bolts and seals	8021	8022	8023	8024	8025	8026	8027	8028

*Assembly kit PVB 32*

Description	Code number 157B....									
	1 PVB	2 PVB	3 PVB	4 PVB	5 PVB	6 PVB	7 PVB	8 PVB	9 PVB	10 PVB
PVB's	8000	8001	8002	8003	8004	8005	8006	8007	8008	8009
Weight [kg [lb]]	0.1 [0.2]	0.15 [0.3]	0.25 [0.6]	0.30 [0.7]	0.40 [0.9]	0.45 [1.0]	0.50 [1.1]	0.60 [1.3]	0.65 [1.4]	0.70 [1.6]

*PVLP, shock/and anti-cavitation valves*

Code no. 157B...	2032	2050	2063	2080	2100	2125	2140	2150	2160	2175	2190	2210	2230	2240	2250	2265	2280	2300	2320	2350	
Settings	bar	32	50	63	80	100	125	140	150	160	175	190	210	230	240	250	265	280	300	320	350
	[psi]	460	725	914	1160	1450	1813	2031	2175	2320	2538	2755	3045	3335	3480	3625	3845	4061	4351	4641	5075
Weight [kg [lb]]	0.05 kg [0.17 lb]																				



PVP 100, pump side module

Code no. 161B...	Closed center, PVPV With pilot supply			Open center, PVPF With pilot supply			
	for PVE	for PVE and facility for pilot shut off	for PVE. With integrated priority function	for PVE		for PVE and facility for pilot shut off	
				12 bar	20 bar	12 bar	20 bar
P-port = G 1	5111	5141	-	5110	5112	5140	5142
P-port = 1 <sup>5</sup> / <sub>16</sub> UN	5511	5541	-	5510	5512	5540	5542
P-port = G 3/4      T-port = G1	-	-	5211	-	-	-	-
P-port = G 1 <sup>1</sup> / <sub>16</sub> UN    T-port = 1 <sup>5</sup> / <sub>16</sub> UN	-	-	5611	-	-	-	-
Weight              kg [lb]	8.5 kg [12.30 lb]						

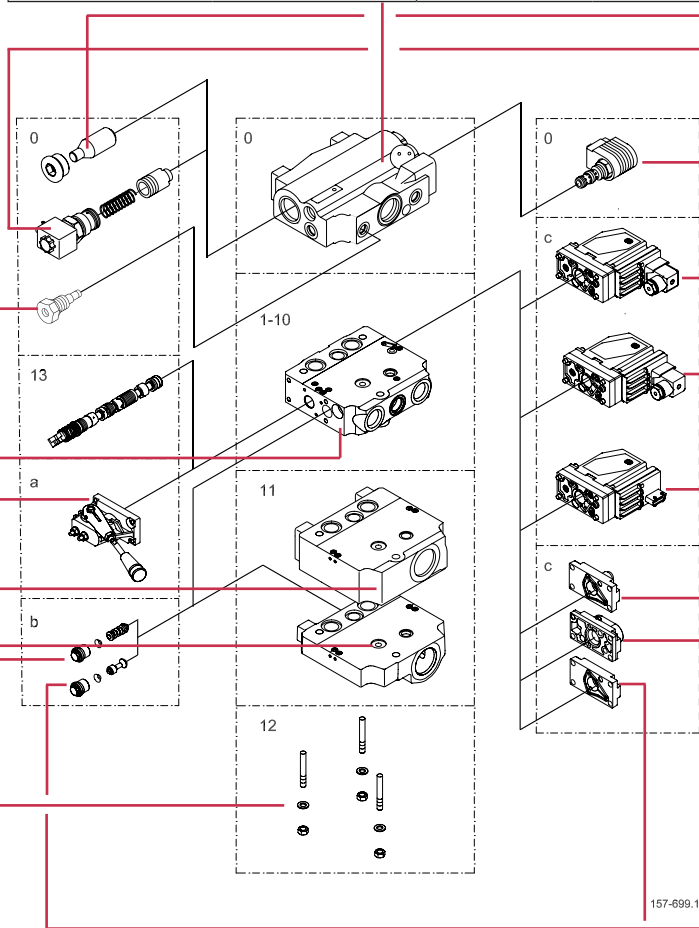

Accessory moduls for PVP 100

Code no.		Weight kg    lb
Plug, PVPD	155G5041*	0.4 [0.9]
Elec. unloading valve, PVPE	12 V 155G5052* 24 V 155G5054*	0.7 [1.1]
Pilot shut off valve, PVPP	12 V 800572719 24 V 800572819	0.3 [0.7]

\* For PVPF only

PVE, electrical actuation

Code no. 157B...		Code No.			Weight kg [lb]
		Hirsch	AMP	Deutch	
PVEO, on-off	12 V	4216	4901	4291	0.6 [1.3]
	24 V	4228	4902	4292	0.6 [1.3]
PVEO-R, on/off	12 V	4217	4903	-	0.6 [1.3]
	24 V	4229	4904	-	0.6 [1.3]
PVEA, active fault mon.		-	4734	4792	0.9 [2.0]
		-	4735	-	0.9 [2.0]
PVEA-DI, active fault mon.		-	4736	4796	0.9 [2.0]
		-	4737	-	0.9 [2.0]
PVEH active fault mon.		4032	4034	4092	1.0 [2.2]
		4033	4035	-	1.0 [2.2]
PVEH-F float pos. act. fault		-	4338	4398	1.0 [2.2]
		-	4036	4096	1.0 [2.2]
PVEH- DI active fault mon.		-	4037	-	1.0 [2.2]
		-	-	-	-
PVEP active fault mon.		-	-	4752	1.0 [2.2]
		-	-	4793	1.0 [2.2]
PVES, active fault mon.		4832	4834	4892	1.0 [2.2]
		4833	4835	-	1.0 [2.2]
PVED-CC, Can-bus interface		-	4943	4944	1.0 [2.2]

PVMD, PVH, PVMR, PVMF covers

Code no. 157B...	Code No.	Weight	
		kg	[lb]
Cover for PVM	0001	0.1	0.2
Hydraulic actuation PVH G 1/4	0008	0.2	0.4
Hydraulic actuation PVH 9/16-18 UNF	0007	0.9	2.0
PVMR (frict. detent)	0015	0.3	0.6
PVMF (mech. float position)	0005	0.3	0.6

PVLA, anti-cavitation valve

Code no. 157B...	Code No.	Weight	
		kg	[lb]
Plug A or B	2002	0.04	0.09
Valve A or B	2001	0.05	0.1

## ORDER SPECIFICATION

An order form for Sauer-Danfoss PVG 100 hydraulic valve is shown on the next page. The form can be obtained from the Sauer-Danfoss Sales Organization.

Both the module selection chart on the previous pages and the order form are divided into fields 0, 1-10, 11, 12, 13, a, b, and c.

Each module has its own field:

- 0: Pump side module PVP
  - Plug for external pilot oil supply PVPC
  - Electrical unloading valve PVPE
  - Electrical pilot shut off valve PVPE
- 1-10: Basic valves PVB
- 13: Main spool PVBS
  - a: Mechanical actuator PVM
  - c: Cover for mechanical actuation PVMD
    - Cover for hydraulic actuation PVH
  - Electrical actuators PVE
  - b: Shock and suction valve PVLP
    - Suction valve PVLA
- 11: End plate PVSI
  - Tank module PVT
  - Interface module PVTI
- 12: Assembly kit PVAS

### Please state

- Code numbers of all modules required
- Required setting (P) for pump side module

### Standard and option assembly

The PVG 100 valve group is assembled the way the module selection chart shows if the code number for PVM is written in field a, and the code number for PVMD, PVE or PVH in field c.

The valve group is assembled so that the mechanical actuator is mounted on the opposite end of the basic module, if the code number for PVM is written in field c of the order form and the code numbers for PVMD, PVE or PVH in field a.

### Reordering

The space at the top right-hand corner of the form is for Sauer-Danfoss to fill in. The code number for the whole of the specified valve group (PVG No.) is entered here. In the event of a repeat order all you have to do is enter the number Sauer-Danfoss has given on the initial confirmation of order.

Subsidiary/Dealer	PVG No.
Customer	Customer No.
Application	Revision No.

Function	A-Port	<b>0</b> 161B _____ p = _____ bar _____	B-Port
	<b>a</b> 157B	<b>1</b> _____ <b>13</b>	157B <b>c</b>
	<b>b</b> 157B	LS <sub>A</sub> _____ bar LS <sub>B</sub> _____ bar	157B <b>b</b>
	<b>a</b> 157B	<b>2</b> _____ <b>13</b>	157B <b>c</b>
	<b>b</b> 157B	LS <sub>A</sub> _____ bar LS <sub>B</sub> _____ bar	157B <b>b</b>
	<b>a</b> 157B	<b>3</b> _____ <b>13</b>	157B <b>c</b>
	<b>b</b> 157B	LS <sub>A</sub> _____ bar LS <sub>B</sub> _____ bar	157B <b>b</b>
	<b>a</b> 157B	<b>4</b> _____ <b>13</b>	157B <b>c</b>
	<b>b</b> 157B	LS <sub>A</sub> _____ bar LS <sub>B</sub> _____ bar	157B <b>b</b>
	<b>a</b> 157B	<b>5</b> _____ <b>13</b>	157B <b>c</b>
	<b>b</b> 157B	LS <sub>A</sub> _____ bar LS <sub>B</sub> _____ bar	157B <b>b</b>
	<b>a</b> 157B	<b>6</b> _____ <b>13</b>	157B <b>c</b>
	<b>b</b> 157B	LS <sub>A</sub> _____ bar LS <sub>B</sub> _____ bar	157B <b>b</b>
	<b>a</b> 157B	<b>7</b> _____ <b>13</b>	157B <b>c</b>
	<b>b</b> 157B	LS <sub>A</sub> _____ bar LS <sub>B</sub> _____ bar	157B <b>b</b>
	<b>a</b> 157B	<b>8</b> _____ <b>13</b>	157B <b>c</b>
	<b>b</b> 157B	LS <sub>A</sub> _____ bar LS <sub>B</sub> _____ bar	157B <b>b</b>
	<b>a</b> 157B	<b>9</b> _____ <b>13</b>	157B <b>c</b>
	<b>b</b> 157B	LS <sub>A</sub> _____ bar LS <sub>B</sub> _____ bar	157B <b>b</b>
	<b>a</b> 157B	<b>10</b> _____ <b>13</b>	157B <b>c</b>
	<b>b</b> 157B	LS <sub>A</sub> _____ bar LS <sub>B</sub> _____ bar	157B <b>b</b>
Remarks		<b>11</b> _____	
		<b>12</b> _____	

Filled in by	Date
--------------	------

Subsidiary/Dealer	PVG No.
Customer	Customer No.
Application	Revision No.

Function	A-Port	O 161B _____ p = _____ psi _____	B-Port
	a 157B	<b>1</b> _____ <b>13</b>	157B <b>c</b>
	b 157B	LS <sub>A</sub> _____ psi LS <sub>B</sub> _____ psi	157B <b>b</b>
	a 157B	<b>2</b> _____ <b>13</b>	157B <b>c</b>
	b 157B	LS <sub>A</sub> _____ psi LS <sub>B</sub> _____ psi	157B <b>b</b>
	a 157B	<b>3</b> _____ <b>13</b>	157B <b>c</b>
	b 157B	LS <sub>A</sub> _____ psi LS <sub>B</sub> _____ psi	157B <b>b</b>
	a 157B	<b>4</b> _____ <b>13</b>	157B <b>c</b>
	b 157B	LS <sub>A</sub> _____ psi LS <sub>B</sub> _____ v	157B <b>b</b>
	a 157B	<b>5</b> _____ <b>13</b>	157B <b>c</b>
	b 157B	LS <sub>A</sub> _____ psi LS <sub>B</sub> _____ psi	157B <b>b</b>
	a 157B	<b>6</b> _____ <b>13</b>	157B <b>c</b>
	b 157B	LS <sub>A</sub> _____ psi LS <sub>B</sub> _____ psi	157B <b>b</b>
	a 157B	<b>7</b> _____ <b>13</b>	157B <b>c</b>
	b 157B	LS <sub>A</sub> _____ psi LS <sub>B</sub> _____ psi	157B <b>b</b>
	a 157B	<b>8</b> _____ <b>13</b>	157B <b>c</b>
	b 157B	LS <sub>A</sub> _____ psi LS <sub>B</sub> _____ psi	157B <b>b</b>
	a 157B	<b>9</b> _____ <b>13</b>	157B <b>c</b>
	b 157B	LS <sub>A</sub> _____ psi LS <sub>B</sub> _____ psi	157B <b>b</b>
	a 157B	<b>10</b> _____ <b>13</b>	157B <b>c</b>
	b 157B	LS <sub>A</sub> _____ psi LS <sub>B</sub> _____ psi	157B <b>b</b>
Remarks		<b>11</b> _____	
		<b>12</b> _____	

Filled in by	Date
--------------	------



PVG 100 Proportional Valve  
Technical Information  
Notes



PVG 100 Proportional Valve  
Technical Information  
Notes



PVG 100 Proportional Valve  
Technical Information  
Notes



## OUR PRODUCTS

Hydrostatic transmissions  
Hydraulic power steering  
Electric power steering  
Electrohydraulic power steering  
Closed and open circuit axial piston pumps and motors  
Gear pumps and motors  
Bent axis motors  
Orbital motors  
Transit mixer drives  
Planetary compact gears  
Proportional valves  
Directional spool valves  
Cartridge valves  
Hydraulic integrated circuits  
Hydrostatic transaxles  
Integrated systems  
Fan drive systems  
Electrohydraulics  
Microcontrollers and software  
Electric motors and inverters  
Joysticks and control handles  
Displays  
Sensors

## Sauer-Danfoss Mobile Power and Control Systems – Market Leaders Worldwide

Sauer-Danfoss is a comprehensive supplier providing complete systems to the global mobile market.

Sauer-Danfoss serves markets such as agriculture, construction, road building, material handling, municipal, forestry, turf care, and many others.

We offer our customers optimum solutions for their needs and develop new products and systems in close cooperation and partnership with them.

Sauer-Danfoss specializes in integrating a full range of system components to provide vehicle designers with the most advanced total system design.

Sauer-Danfoss provides comprehensive worldwide service for its products through an extensive network of Global Service Partners strategically located in all parts of the world.

Local address:

Sauer-Danfoss (US) Company  
2800 East 13th Street  
Ames, IA 50010, USA  
Phone: +1 515 239-6000  
Fax: +1 515 239 6618

Sauer-Danfoss ApS  
DK-6430 Nordborg, Denmark  
Phone: +45 7488 4444  
Fax: +45 7488 4400

Sauer-Danfoss GmbH & Co. OHG  
Postfach 2460, D-24531 Neumünster  
Krokamp 35, D-24539 Neumünster, Germany  
Phone: +49 4321 871-0  
Fax: +49 4321 871 122

Sauer-Danfoss-Daikin LTD  
Sannomiya Grand Bldg. 8F  
2-2-21 Isogami-dori, Chuo-ku  
Kobe, Hyogo 651-0086, Japan  
Phone: +81 78 231 5001  
Fax: +81 78 231 5004