

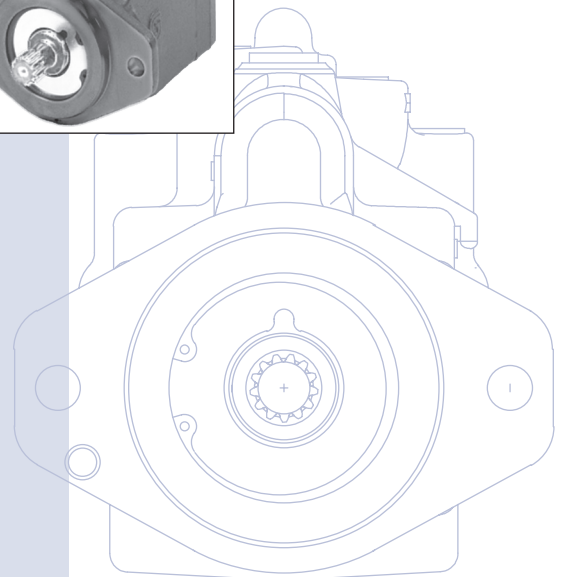

L and K Frame Variable Motors

Technical Information

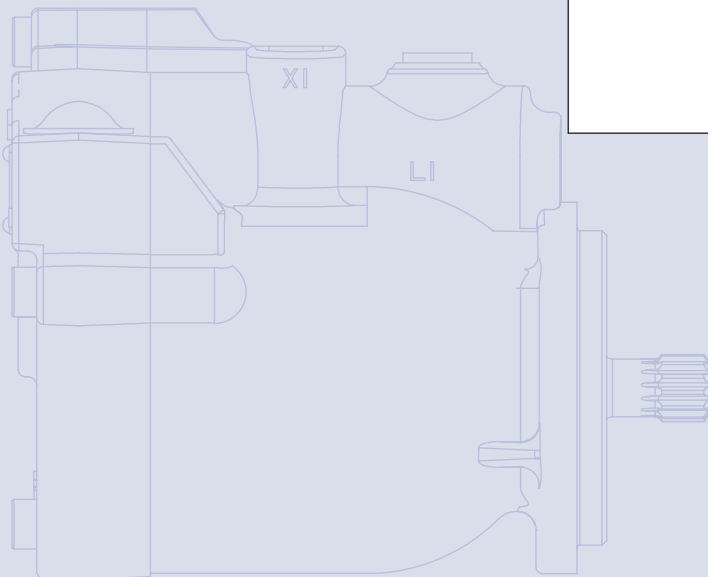
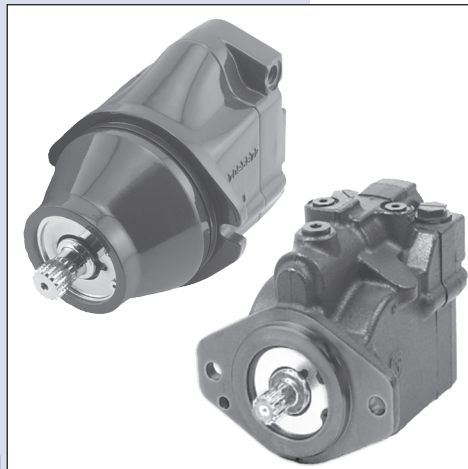
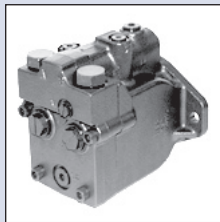
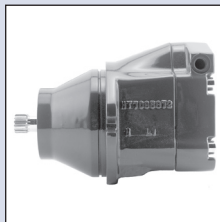
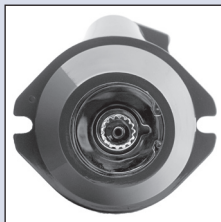

REVISIONS

Table of Revisions

Date	Page	Changed	Rev.
April 2008	6	corrected the schematic drawings	BE
January 2008	17	removed displacement limiter setting F12 - 65.3%	BD
April 2007	18	LV (41 pulses/rev) KV (44 pulses/rev)	BC
March 2007	18	changed 41 pulses/rev to 44 pulses/rev	BB
October 2006	Various	Added Loop flushing valve and 5 bolt endcap	B
February 2004	-	First edition	A

© 2008 Sauer-Danfoss. All rights reserved.

Sauer-Danfoss accepts no responsibility for possible errors in catalogs, brochures and other printed material. Sauer-Danfoss reserves the right to alter its products without prior notice. This also applies to products already ordered provided that such alterations aren't in conflict with agreed specifications. All trademarks in this material are properties of their respective owners. Sauer-Danfoss and the Sauer-Danfoss logotype are trademarks of the Sauer-Danfoss Group.

GENERAL DESCRIPTION	Basic Design	5
	Key features	5
	System circuit diagram.....	6
	Motor schematic diagrams	6
TECHNICAL SPECIFICATIONS	Overview	7
	Features and options	7
	Specifications.....	7
	Operating parameters	7
	Fluid specifications	7
	Performance.....	8
OPERATING PARAMETERS	Fluids.....	9
	Viscosity	9
	Temperature.....	9
	Charge pressure.....	9
	Case pressure	9
	Pressure ratings.....	10
	Speed ratings.....	10
SYSTEM DESIGN PARAMETERS	Installation	11
	Filtration.....	11
	Reservoir.....	11
	Overpressure protection	11
	Loop flushing	12
	Charge flow	12
	Charge pressure.....	12
	Redundant braking system requirement	12
	Series operation.....	12
	Shaft loads	13
	Duty cycle and bearing life	13
	Hydraulic equations helpful for motor selection	14

PRODUCT CODING	Name plate	15
	Model code.....	16
FEATURES AND OPTIONS	Speed sensor.....	18
	Output shafts	18
	Lubrication of splined shafts	18
	Loop flushing	19
	Displacement limiters.....	22
	Motor rotation	22
	Controls.....	22
	Brake release port (cartridge motors).....	22
Control orificing	22	
INSTALLATION DRAWINGS	SAE-B mount (LV/KV)	23
	Cartridge (LC/KC).....	26

BASIC DESIGN

The L and K Frame variable motors are light to medium power two-position axial piston motors incorporating an integral servo piston. They are designed for operation in closed circuit applications. The L and K Frame motors consist of five unique rotating groups (displacements) and two housing (mounting) configurations. An SAE-B, two-bolt, and a cartridge style (for space-optimized gearbox mounting) configurations are available for each frame. Maximum speeds and maximum applied pressures for each displacement vary. The standard control is a direct acting single line hydraulic control. For SAE-B mount motors a two line control is also available. The integral servo piston controls motor displacement.

The motor is spring biased to maximum displacement and hydraulically shifted to minimum displacement. Minimum and maximum displacement can be set with fixed internal stops. The large diameter servo piston allows smooth acceleration and deceleration with relatively large circuit orificing.

The motor is ideally configured for installations requiring compact packaging and optimized plumbing, such as wheel ends. One face of the motor contains all hydraulic porting. Two standard porting configurations are available: twin radial (side) or axial (end) O-ring boss main ports.

Cross section, SAE-B mount

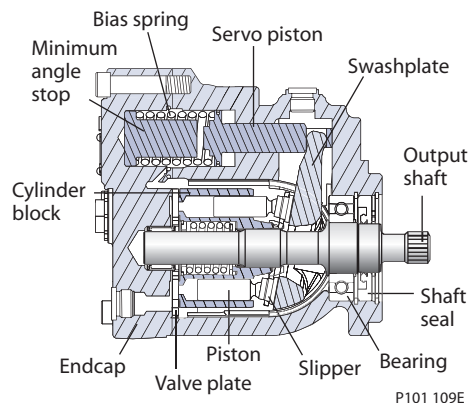

Cross section, cartridge mount

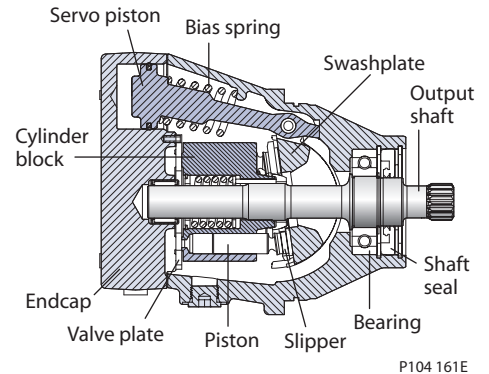

KEY FEATURES

- Five displacements allow the optimum selection of hydraulic motor for the lowest possible installed cost.
- SAE-B, two-bolt, and cartridge mounting configurations available.
- Short and compact; fits into existing installation with improved porting.
- Three clean sides with superior clearance and access to mounting bolts.
- High Efficiency - nine piston rotating groups with 18 degree maximum angle.
- Versatility - working displacement range of 3.4:1 with a minimum angle option to one degree overcenter (-1°).
- Reliability - uses existing and proven technology.
- Worldwide service and technical support.

SYSTEM CIRCUIT DIAGRAM

Pictorial system diagram

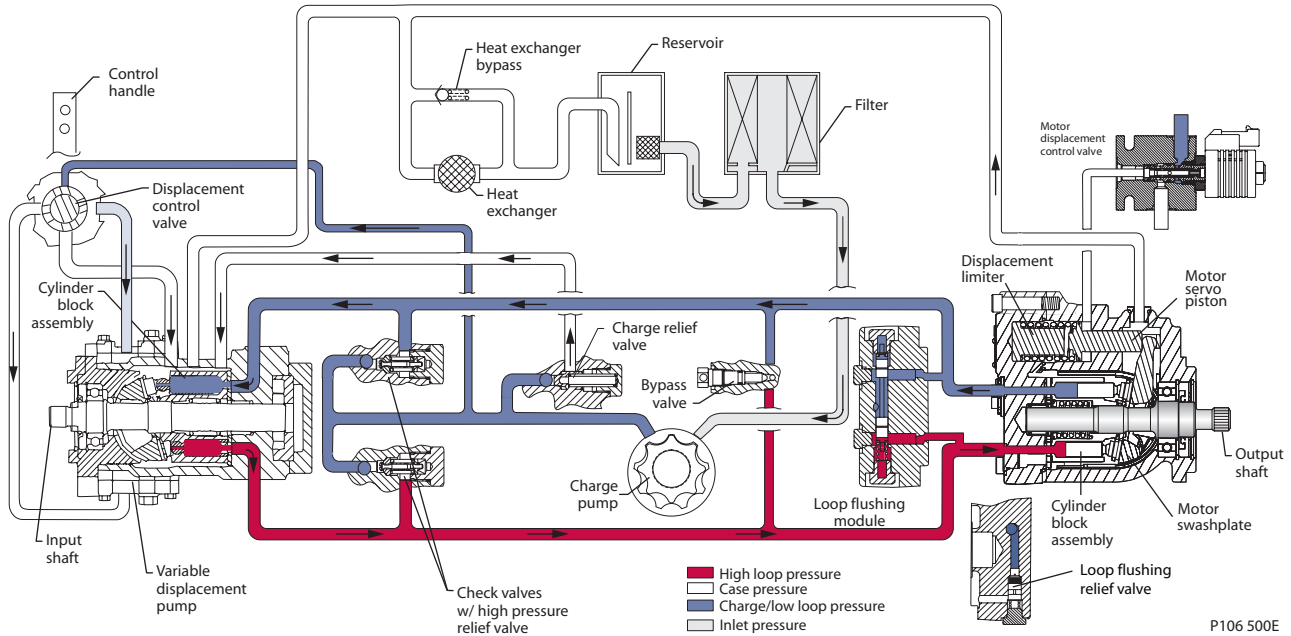

P106 500E

The circuit above shows the LV/KV motor in a simple closed-loop hydrostatic propel application. The motor is driven by a Series 40 M46 axial piston pump with manual displacement control. The motor shown uses a single line hydraulic displacement control. Control pressure applied through an external control valve shifts the motor to minimum displacement, spring force returns the motor to maximum displacement in the absence of control input.

MOTOR SCHEMATIC DIAGRAMS

Motor schematic, single line control

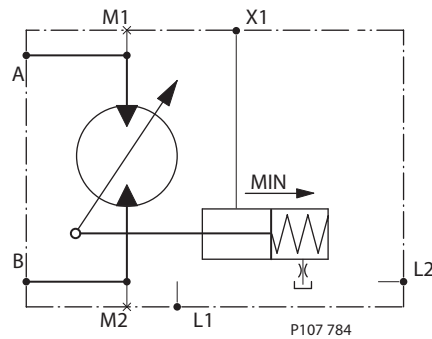

Motor schematic, dual line control

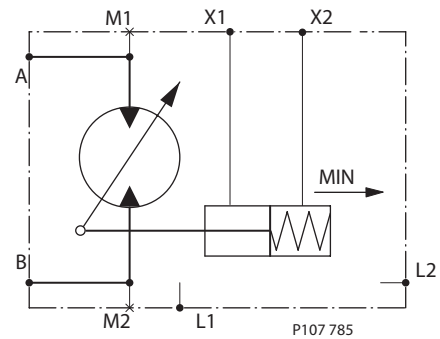

OVERVIEW

Specifications and operating parameters for L and K Frame motors are given here for quick reference. For additional information, see *Operating parameters*, page 10, *Features and options*, page 19 and *Product coding*, page 16.

FEATURES AND OPTIONS

Mount	SAE-B (LV/KV)	Cartridge (LC/KC)
Motor type	Inline, axial piston, positive displacement, two-speed variable motors	
Displacement	L: 25, 30, or 35 cm ³ [1.50, 1.83, or 2.14 in ³] K: 38 or 45 cm ³ [2.32 or 2.75 in ³]	
Rotation	Bidirectional	
Installation position	Discretionary: Housing must always be filled with hydraulic fluid	
Porting	SAE O-ring boss, axial or twin radial	SAE O-ring boss, twin radial
Output shafts	Splined 13 or 15 tooth 16/32 pitch, 0.875 in. straight keyed, and 1:8 taper	Splined 13 or 15 tooth 16/32 pitch
Control options	Single or dual line hydraulic control	Single line hydraulic control
Displacement limiter	Fixed maximum and minimum displacement limiters available	
Speed sensor	Available - refer to Features and options section	
Loop Flushing Valve	Available - refer to Features and options section	

SPECIFICATIONS

Parameter	Unit	L25	L30	L35	K38	K45
Displacement (maximum)	cm ³ [in ³]	25 [1.50]	30 [1.83]	35 [2.14]	38 [2.32]	45 [2.75]
Weight (cartridge and SAE-B)	kg [lb]	15.4 [34]				
Mass moment of inertia of rotating components	kg·m ² [slug·ft ²]	0.001666 [0.001229]	0.001582 [0.001167]	0.001530 [0.001128]	0.002326 [0.001716]	0.002286 [0.001687]
Theoretical torque	N·m/bar [lbf·in/1000psi]	0.40 [244]	0.48 [293]	0.56 [347]	0.60 [366]	0.72 [439]

OPERATING PARAMETERS

Parameter	Unit	L25	L30	L35	K38	K45	
System pressure	continuous	bar [psi]	210 [3045]	175 [2540]	140 [2030]	210 [3045]	175 [2540]
	maximum		415 [6020]	350 [5075]	280 [4060]	415 [6020]	350 [5075]
Speed limit (at max. disp)	continuous	min ⁻¹ (rpm)	3400	3500	3600	3600	3500
	maximum		3950	4150	4300	4000	3900
Speed limit (at min. disp)	continuous		4400	4450	4500	4650	4500
	maximum		5000	5150	5300	5200	5050
Case pressure	continuous	bar [psi]	2 [29]				
	maximum		6 [87]				
Shift pressure (single line control)	minimum	bar [psi]	14 [203]				
	maximum		69 [1000]				

FLUID SPECIFICATIONS

Ratings and data are based on operation with premium petroleum-based hydraulic fluids containing oxidation, rust, and foam inhibitors.

Parameter	Unit	Minimum	Continuous	Maximum
Viscosity	mm ² /sec (cSt) [SUS]	7 [47]	12-60 [70-278]	1600 [7500]
Temperature	°C [°F]	-40 [-40]	82 [180]	104 [220]
Cleanliness		ISO 4406 Class 18/13 or better		
Filtration efficiency	suction filtration	$\beta_{35-44}=75$ ($\beta_{10} \geq 1.5$)		
	charge filtration	$\beta_{15-20}=75$ ($\beta_{10} \geq 10$)		

PERFORMANCE

Volumetric and overall efficiency vs. speed

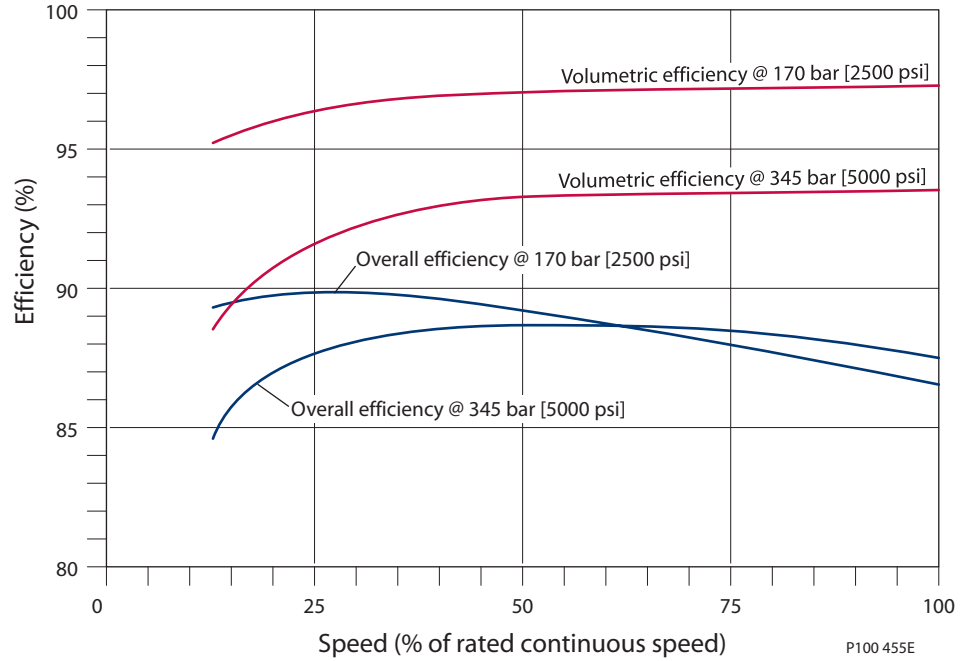

Typical performance at max. displacement

Overall efficiency (pressure vs. speed)

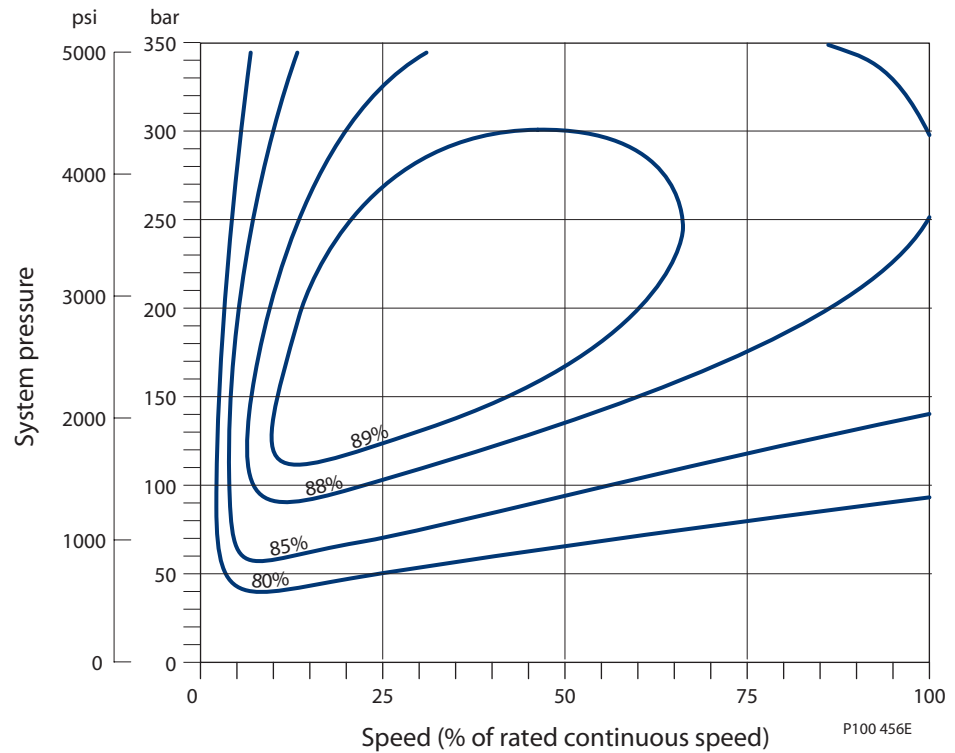

Typical performance at max. displacement

FLUIDS

Ratings and performance data for L and K Frame motors are based on operating with premium hydraulic fluids containing oxidation, rust, and foam inhibitors. These include premium turbine oils, API CD engine oils per SAE J183, M2C33F or G automatic transmission fluids (ATF), Dexron II (ATF) meeting Allison C-3 or Caterpillar T0-2 requirements, and certain specialty agricultural tractor fluids. For more information on hydraulic fluid selection, see Sauer-Danfoss publications: **520L0463**, *Hydraulic Fluids and Lubricants, Technical Information*, and **520L465**, *Experience with Biodegradable Hydraulic Fluids, Technical Information*.

VISCOSITY

Maintain fluid viscosity within the recommended range for maximum efficiency and bearing life. **Minimum viscosity** should only occur during brief occasions of maximum ambient temperature and severe duty cycle operation. **Maximum viscosity** should only occur at cold start. Limit speeds until the system warms up.

Fluid viscosity limits

Condition	mm ² /s (cSt)	SUS
Minimum	7	47
Continuous	12-60	70-278
Maximum	1600	7500

TEMPERATURE

Maintain fluid temperature within the limits shown in the table. **Minimum temperature** relates to the physical properties of the component materials. Cold oil will not affect the durability of the motor components. However, it may affect the ability of the motor to transmit power. **Maximum temperature** is based on material properties. Don't exceed it. Measure maximum temperature at the hottest point in the system. This is usually the case drain.

Temperature limits

Minimum (intermittent, cold start)	- 40° C [- 40° F]
Continuous	85° C [185° F]
Maximum	105° C [221° F]

Ensure fluid temperature and viscosity limits are concurrently satisfied.

CHARGE PRESSURE

L and K Frame motors can be operated in closed and open circuit applications. The motors require a charge (positive pressure) in the low side of the system loop for proper lubrication and rotating group operation. Maintain low loop (charge) pressure at a minimum of 3 bar [44 psi] above case pressure.

CASE PRESSURE

Maintain case pressure within the limits shown in the table. The housing must always be filled with hydraulic fluid.

Case pressure limits

Maximum (continuous)	2 bar [29 psi]
Intermittent (cold start)	6 bar [87 psi]

ⓘ Caution

Operating outside of charge and case pressure limits will damage the motor. To minimize this risk, use full size inlet and case drain plumbing, and limit line lengths.

SHIFT PRESSURE

Minimum shift pressure required to keep motor swashplate at minimum angle is 14 bar [203 psi].

PRESSURE RATINGS

The table, *Specifications*, page 8, gives maximum and continuous pressure ratings for each displacement. Not all displacements operate under the same pressure limits. Definitions of the operating pressure limits appear below.

System pressure is the differential pressure between system ports A and B. It is the dominant operating variable affecting hydraulic unit life. High system pressure, which results from high load, reduces expected life. System pressure must remain at or below continuous working pressure during normal operation to achieve expected life.

Continuous working pressure is the average, regularly occurring operating pressure. Operating at or below this pressure should yield satisfactory product life.

Maximum (peak) working pressure is the highest intermittent pressure allowed. Maximum machine load should never exceed this pressure. For all applications, the load should move below this pressure.

All pressure limits are differential pressures referenced to low loop (charge) pressure. Subtract low loop pressure from gauge readings to compute the differential.

SPEED RATINGS

The table, *Specifications*, page 8, gives rated and maximum speeds for each displacement. Not all displacements operate under the same speed limits. Definitions of these speed limits appear below.

Continuous speed is the maximum recommended operating speed at full power condition. Operating at or below this speed should yield satisfactory product life. In vehicle propel applications, maximum motor speed during unloaded, on-road travel over level ground should not exceed this limit.

Maximum speed is the highest operating speed permitted. Exceeding maximum speed reduces motor life and can cause loss of hydrostatic power and braking capacity. Never exceed the maximum speed limit under any operating conditions.

⚠ Warning**Unintended vehicle or machine movement hazard.**

The loss of hydrostatic drive line power, in any mode of operation (forward, neutral, or reverse) may cause the system to lose hydrostatic braking capacity. You must provide a braking system, redundant to the hydrostatic transmission, sufficient to stop and hold the vehicle or machine in the event of hydrostatic drive power loss.

INSTALLATION

L and K Frame motors may be installed in any position. The motor housing must always remain full of hydraulic fluid.

Fill the motor housing and system lines with clean fluid during installation. Connect the case drain line to the uppermost drain port (L1 or L2) to keep the housing full during operation.

To allow unrestricted flow to the reservoir, use a dedicated drain line. Connect it below the minimum reservoir fluid level and as far away from the reservoir outlet as possible. Use plumbing adequate to maintain case pressure within prescribed limits (see *Case pressure limits*, page 10).

FILTRATION

To prevent damage to the motor, including premature wear, fluid entering the motor must be free of contaminants. L and K Frame motors require system filtration capable of maintaining fluid cleanliness at ISO 4406-1999 class 22/18/13 or better.

Consider these factors when selecting a system filter:

- Cleanliness specifications
- Contaminant ingress rates
- Flow capacity
- Desired maintenance interval

Typically, a filter with a beta ratio of $\beta_{10} = 1.5$ to 2.0 is adequate. However, open circuit systems supplied from a common reservoir may have considerably higher requirements. Because each system is unique, only a thorough testing and evaluation program can fully validate the filtration system. For more information, see Sauer-Danfoss publication **520L0467**, *Design Guidelines for Hydraulic Fluid Cleanliness*.

RESERVOIR

The reservoir provides clean fluid, dissipates heat, and removes entrained air from the hydraulic fluid. It allows for fluid volume changes associated with fluid expansion and cylinder differential volumes. Minimum reservoir capacity depends on the volume needed to perform these functions. Typically, a capacity of one half the charge pump flow (per minute) is satisfactory for a closed reservoir. Open circuit systems sharing a common reservoir will require greater fluid capacity.

Locate the reservoir outlet (suction line) near the bottom, allowing clearance for settling foreign particles. Place the reservoir inlet (return lines) below the lowest expected fluid level, as far away from the outlet as possible.

OVERPRESSURE PROTECTION

L and K Frame motors have no internal overpressure protection. Therefore, relief valves or pressure limiters are required to maintain system pressure within prescribed limits. Relief valves are adequate to protect against transient or unusually rapid load application, but excessive or continuous flow through them adds heat to the system and can damage the fluid. In applications operating at or near pressure, use a pressure compensating variable pump.

LOOP FLUSHING

Closed circuit systems may require loop flushing to meet temperature and cleanliness requirements. A loop flushing valve removes hot fluid from the low pressure side of the system loop for additional cooling and filtering. Ensure the charge pump provides adequate flow for loop flushing and the loop flushing valve does not cause charge pressure to drop below recommended limits.

CHARGE FLOW

Closed circuit applications require a charge pump to make up for lubrication and cooling losses, and to charge the low pressure side of the system loop. The total charge flow required is a sum of the charge flow requirements for the pump, plus the flow requirements for all motors in the system, plus any external loop flushing requirements.

CHARGE PRESSURE

For proper operation, L and K Frame motors require a minimum pressure in the low side of the system loop. This **charge pressure** keeps the piston slippers seated against the swashplate and ensures proper lubrication of the motor components. Insufficient charge pressure limits motor speed. For operation at continuous speed, the minimum charge pressure is 3 bar [44 psi] above case pressure.

**REDUNDANT BRAKING
SYSTEM REQUIREMENT****⚠ Warning****Unintended vehicle or machine movement hazard.**

The loss of hydrostatic drive line power, in any mode of operation (forward, neutral, or reverse) may cause the system to lose hydrostatic braking capacity. You must provide a braking system, redundant to the hydrostatic transmission, sufficient to stop and hold the vehicle or machine in the event of hydrostatic drive power loss.

SERIES OPERATION

L and K Frame motors may be operated in series configuration as long as system, charge, and case pressure limits are satisfied. Operating motors in series significantly impacts bearing life. Contact your Sauer-Danfoss representative for assistance when applying L and K Frame motors in series configuration.

SHAFT LOADS

L and K Frame motors have bearings capable of accepting some external radial and thrust loads. The external radial shaft load limits are a function of the load position, orientation, and the operating conditions of the motor.

Shaft external load limits

Frame		L		K	
Mounting configuration		SAE	Cartridge	SAE	Cartridge
Maximum allowable external moment (M_e)	N•M	7.7	21.7	13.3	37.5
	lbf•in	68	192	118	332
Maximum allowable thrust load (T)	N	750		1100	
	lbf	169		247	

The table above gives the maximum allowable external moment (M_e) for a 25% bearing life reduction, with optimum load orientation, operating at maximum continuous pressure (see *Specifications*, page 8). You can compute the allowable radial load (R_e) from the moment (M_e), and the load distance (L) from the mounting flange, using the formula below. The thrust load (T) is the maximum allowable without bearing life reduction, based on the radial load for 25% life reduction and maximum continuous pressure. Maximum allowable thrust load (T) is a function of external radial load and operating pressure, and may or may not impact bearing life. If thrust or radial loads exist that are not a function of the operating load of the motor, or exceed these limits, contact your Sauer-Danfoss representative for application assistance.

Radial load formula

$$M_e = R_e \cdot L$$

- L = Distance from mounting flange to point of load
- M_e = Maximum external moment
- R_e = Maximum radial side load

Shaft load orientation

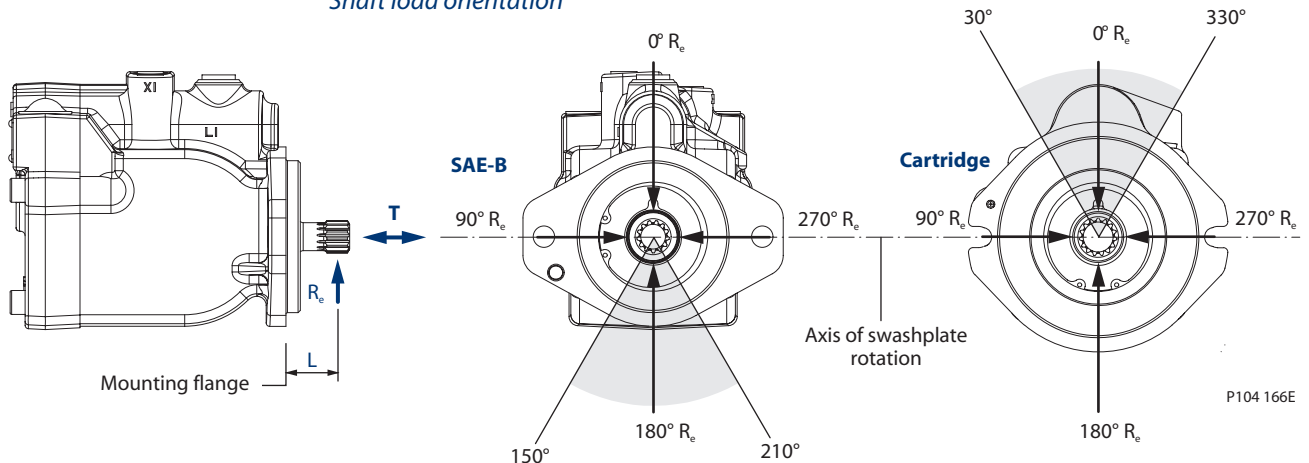

DUTY CYCLE AND BEARING LIFE

All shaft loads affect bearing life. In applications where external shaft loads exist, maximize bearing life by orientating the load in the optimal position, as shown in the shaded area above. We recommend tapered shafts or clamp-type couplings for applications with radial shaft loads.

Knowing the operating conditions of your application is the best way to ensure proper motor selection. With accurate duty cycle information, your Sauer-Danfoss representative can assist in calculating expected motor life.

**HYDRAULIC EQUATIONS
 HELPFUL FOR MOTOR
 SELECTION**

Use the following equations to compute output power, torque, speed, and input flow. Selecting the right motor starts with an evaluation of system requirements such as speed and torque. Select a motor that will transmit the required torque, then select a pump that will meet the flow and pressure requirements of the motor. For more information on hydrostatic drive selection, refer to Sauer-Danfoss applications guideline **BLN-9885**, *Selection of Drive Line Components*.

Based on SI units

$$\text{Input flow } Q = \frac{V_g \cdot n}{1000 \cdot \eta_v} \quad (\text{l/min})$$

$$\text{Motor speed } n = \frac{Q \cdot 1000 \cdot \eta_v}{V_g} \quad \text{min}^{-1}(\text{rpm})$$

$$\text{Output torque } M = \frac{V_g \cdot \Delta p \cdot \eta_m}{20 \cdot \pi} \quad (\text{N}\cdot\text{m})$$

$$\text{Output power } P = \frac{Q \cdot \Delta p \cdot \eta_t}{600} \quad (\text{kW})$$

Based on US units

$$\text{Input flow } Q = \frac{V_g \cdot n}{231 \cdot \eta_v} \quad (\text{US gal/min})$$

$$\text{Motor speed } n = \frac{Q \cdot 231 \cdot \eta_v}{V_g} \quad \text{min}^{-1}(\text{rpm})$$

$$\text{Output torque } M = \frac{V_g \cdot \Delta p \cdot \eta_m}{2 \cdot \pi} \quad (\text{lbf}\cdot\text{in})$$

$$\text{Output power } P = \frac{Q \cdot \Delta p \cdot \eta_t}{1714} \quad (\text{hp})$$

Where:

SI units [US units]

V_g	= Displacement per revolution	cm^3/rev [in^3/rev]
p_o	= Outlet pressure	bar [psi]
p_i	= Inlet pressure	bar [psi]
Δp	= $p_o - p_i$ (system pressure)	bar [psi]
n	= Speed	min^{-1} (rpm)
η_v	= Volumetric efficiency	
η_m	= Mechanical efficiency	
η_t	= Overall efficiency ($\eta_v \cdot \eta_m$)	

NAME PLATE

L and K Frame motors are identified by a name plate affixed to the motor housing. The nameplate contains the model number, model code, serial number, and country of manufacture.

Name plate

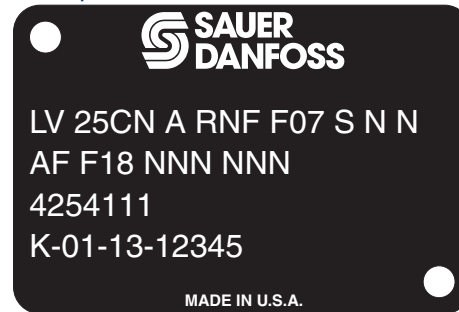

Model number

A Sauer-Danfoss model number is issued for every unique configuration. Use this number when placing orders.

Model code

The model code completely defines the options for a specific unit. See *Model code*, next page, for available options and codes.

Serial number

Every unit is identified by a unique serial number. The serial number gives manufacturing location, year and week built, and a unique sequence number. The serial number in the example to the left is decoded as:

K	Lawrence, Kansas, USA
01	Year 2001
13	Week 13
67890	Sequence number

MODEL CODE

A B C1 2 D E 1 2 3 F G H J K 1 2 L M N
 □□ □□□□ □ □NF □□□ □ N □ □F F□□ NNN NNN

A Frame

Code	Description
L	Frame size: displacements 25, 30, and 35 cm ³ [1.50, 1.83, and 2.14 in ³]
K	Frame size: displacements 38 and 45 cm ³ [2.32 and 2.75 in ³]

B Mount

Code	Description
V	SAE-B
C	Cartridge

C1 Displacement, continuous pressure rating

Code	Displacement	Continuous pressure rating
L25C	25 cm ³ /rev [1.50 in ³ /rev]	210 bar [3045 psi]
L30D	30 cm ³ /rev [1.83 in ³ /rev]	175 bar [2540 psi]
L35E	35 cm ³ /rev [2.14 in ³ /rev]	140 bar [2030 psi]
K38C	38 cm ³ /rev [2.32 in ³ /rev]	210 bar [3045 psi]
K45D	45 cm ³ /rev [2.75 in ³ /rev]	175 bar [2540 psi]

C2 Speed sensing ring

Code	Description
N	None
S	Speed ring installed, 41 pulses per revolution

D Output shaft

Code	Description
A	13 tooth 16/32 pitch per ANSI B92.1-1970 class 5
C	0.875 in straight key (LV/KV only)
D	1:8 taper (LV/KV only)
E	15 tooth 16/32 pitch per ANSI B92.1-1970 class 5

E1 Endcap porting

Code	Description
R	Twin radial, 1 1/16 in-12 O-ring boss
Y	Axial, 1 1/16 in-12 O-ring boss (LV/KV only)

E2 Loop flushing

Code	Description
N	None (standard)
1	Flow = option 1, crack pressure 10.3 bar [150 psi]
2	Flow = option 2, crack pressure 10.3 bar [150 psi]
3	Flow = option 3, crack pressure 10.3 bar [150 psi]

E3 Minimum angle adjustment option

Code	Description
F	Non-adjustable fixed stop

Reference *Loop Flushing* in *Features and options* and *Technical specifications* sections.

SPEED SENSOR

K and L Frame motors are available with an optional speed sensor. This hall-effect pick-up senses motor speed and direction of rotation via a magnetic ring mounted to the cylinder block. The sensor is available with a 4-pin Packard Weather-Pack connector. Specifications appear below. For more information, refer to *Technical Bulletin, KPP Pulse Pick-up, BLN-95-9045*.

KPP Pulse Pick-up with Weather-Pack connector

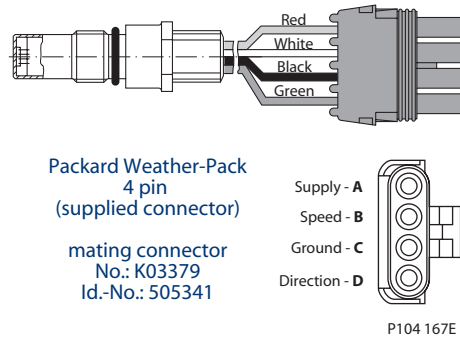

Specifications

Supply voltage	4.5 to 8.5 VDC (regulated)
Output voltage (high)	Supply minus 0.5VDC, minimum (no load)
Output voltage (low)	0.5 VDC Maximum (no load)
Maximum frequency	15 kHz
Max. operating current	20 mA at 1 kHz
Load	15 k Ω to both ground and supply
Peak reverse voltage	-15 VDC continuous
Peak transient voltage	80 VDC for 2 ms (max.)
Pulses per rev.	41 (LV motor) 44 (KV motor)

OUTPUT SHAFTS

L and K Frame variable motors are available with splined, tapered, and straight-keyed shafts. See the following page for details.

Lubrication of splined shafts

Splined shaft couplings require lubrication to minimize corrosion, fretting, and premature wear. Flooded or splashed oil lubrication is ideal. In applications where this is not possible, Sauer-Danfoss recommends you apply a compound of 50% high temperature grease and 50% molybdenum disulfide powder to the splines during installation and at regular intervals during service life. This lubricant is not soluble in oil.

LOOP FLUSHING

K and L motors incorporate an optional integral loop flushing valve. Use the loop flushing valve in circuits requiring the removal of excessive contamination or installations that require the removal of additional fluid from the main hydraulic circuit due to cooling requirements.

K and L motors equipped with an integral loop flushing shuttle valve also include a loop flushing relief valve. The loop flushing relief valve poppet includes an orifice which controls flushing flow. Flushing flow. Use a loop flushing flow of 5 to 8 L/min (1.5 - 2 gpm) is typical.

The opening pressure (indicated in graph below) of the loop flushing relief valve should be equal to or less than the charge pressure setting of the pump. Contact your Sauer-Danfoss representative for assistance.

Loop Flushing valve

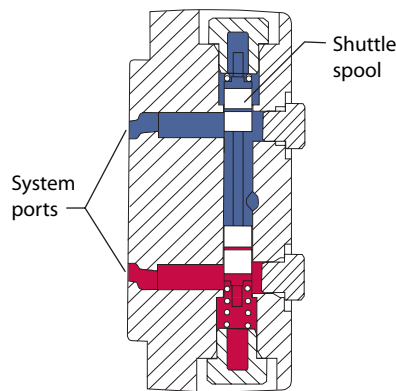

P106 493E

Relief valve

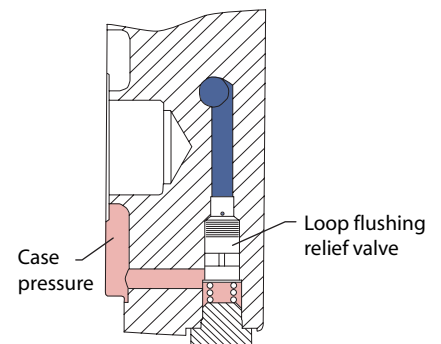

P106 494E

Loop Flushing flow

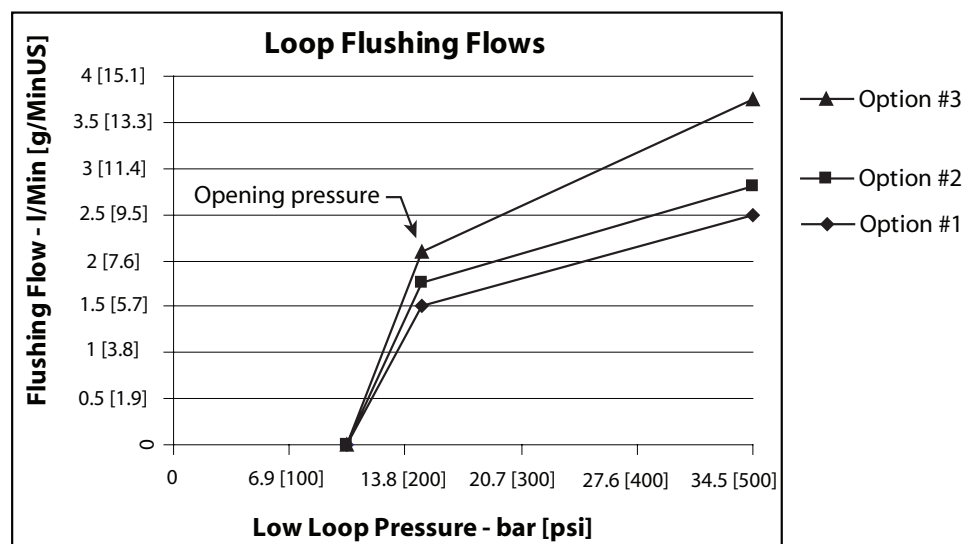

P106 496E

OUTPUT SHAFTS
(continued)

Shaft options

Code	Description	Availability		Torque rating		Drawing
		LV/KV	LC/KC	Continuous N·m [lbf·in]	Maximum N·m [lbf·in]	
A	13 tooth spline 16/32 pitch ANSI B92.1 1970-Class 5	1	—	73 [650] (Continuous torque rating based on spline tooth wear)	226 [2000]	
A	13 tooth spline 16/32 pitch ANSI B92.1 1970-Class 5	—	1	73 [650] (Continuous torque rating based on spline tooth wear)	226 [2000]	
C	Ø 22.225 mm [0.875 in] Straight keyed	1	—	N/A	362 [3200]	

OUTPUT SHAFTS
 (continued)

Code	Description	Availability		Torque rating		Drawing
		LV/KV	LC/KC	Continuous N·m [lbf·in]	Maximum N·m [lbf·in]	
D	Ø 22.225 mm [0.875 in] 1:5 Taper	I	—	N/A	362 [3200]	<p>P104 168</p>
E	15 tooth spline 16/32 pitch ANSI B92.1 1970-Class 5	I	—	153 [1350] (Continuous torque rating based on spline tooth wear)	362 [3200]	<p>P104 170E</p>
E	15 tooth spline 16/32 pitch ANSI B92.1 1970-Class 5	—	I	153 [1350] (Continuous torque rating based on spline tooth wear)	362 [3200]	<p>P104 174E</p>

DISPLACEMENT LIMITERS

L and K Frame variable motors can be equipped with optional fixed (non-adjustable) displacement limiters. Refer to *Maximum angle/Displacement setting*, page 17, for available displacement settings.

MOTOR ROTATION

L and K Frame variable motors are fully bidirectional. The chart to the right gives the direction of rotation with respect to flow direction through the motor.

Rotation by flow direction

Mount	SAE-B	Cartridge
Flow A→B	CCW	CW
Flow B→A	CW	CCW

CONTROLS

L and K Frame variable motors are designed to operate in two positions: maximum and minimum displacement. The motors are spring biased to maximum displacement and hydraulically shifted to minimum displacement. SAE-B mount motors can operate with a single or dual line control. Cartridge mount motors operate with a single line control. Pressure applied at port X1 shifts the motor to minimum displacement. Pressure at X2 (dual line control) can assist the shift to maximum displacement. Refer to the table above for control input pressure range.

Control input pressure limits

LV/KV with single line control	14 to 240 bar [200 to 3500 psi]
LV/KV with dual line control	14 to 35 bar [200 to 500 psi]
LC/KC with single line control	14 to 69 bar [200 to 1000 psi]

Control orificing

SAE-B mount motors with single line controls can have optional, internal, supply and drain orifices installed to regulate control response times. Contact your Sauer-Danfoss representative for available orifice sizes.

Cartridge mount motors and SAE-B mount motors with dual line controls rely on external valving and orificing to regulate shift speeds. You can achieve quick acceleration (shift to min) and slow deceleration (shift to max) simply by installing an orifice in the tank line of the external control valve.

BRAKE RELEASE PORT (CARTRIDGE MOTORS)

Cartridge mount motors are equipped with a brake release port to allow access to the brake-release feature of the gear box from the rear of the motor. This consists of a simple passage through the motor housing with a rear-facing $\frac{7}{16}$ in. SAE O-ring boss port. To locate the port on the gear box, refer to the *Installation drawings*, page 26. Applications using this brake release port require an O-ring to seal the passage against the gear box.

While all motors will have the brake release port, not all gearboxes are compatible with this motor feature. Consult your gearbox manufacturer for suitability and compatibility. If your gearbox is not compatible with this feature, simply leave the port plugged.

SAE-B MOUNT (LV/KV)

Axial ports

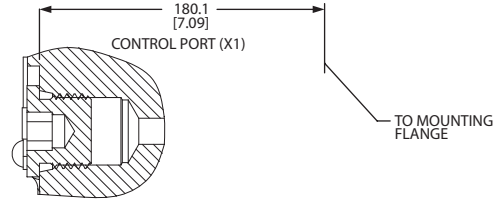

SECTION A-A

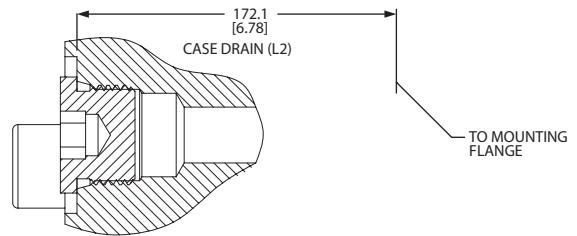
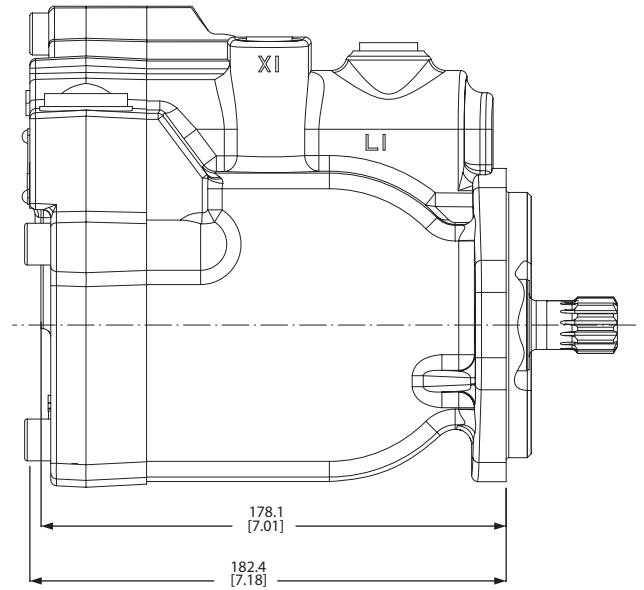
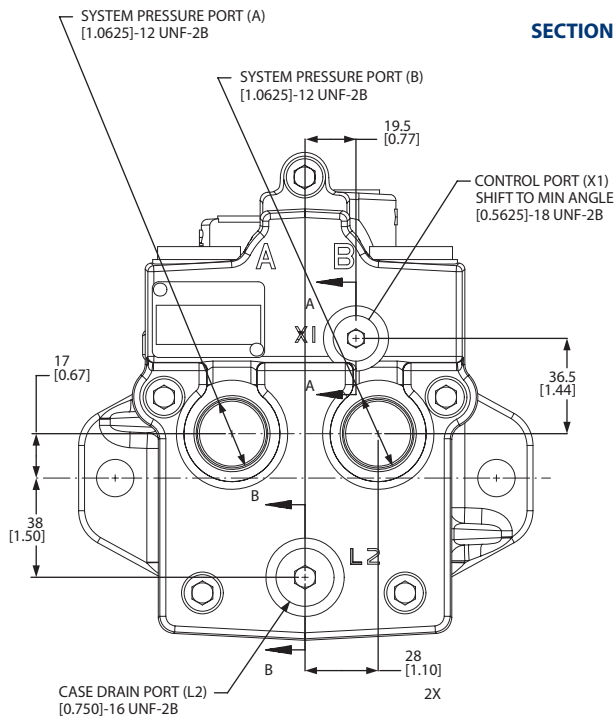

SECTION B-B

P104 181E

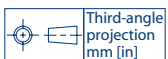

SAE-B MOUNT (LV/KV)
(continued)

Radial ports

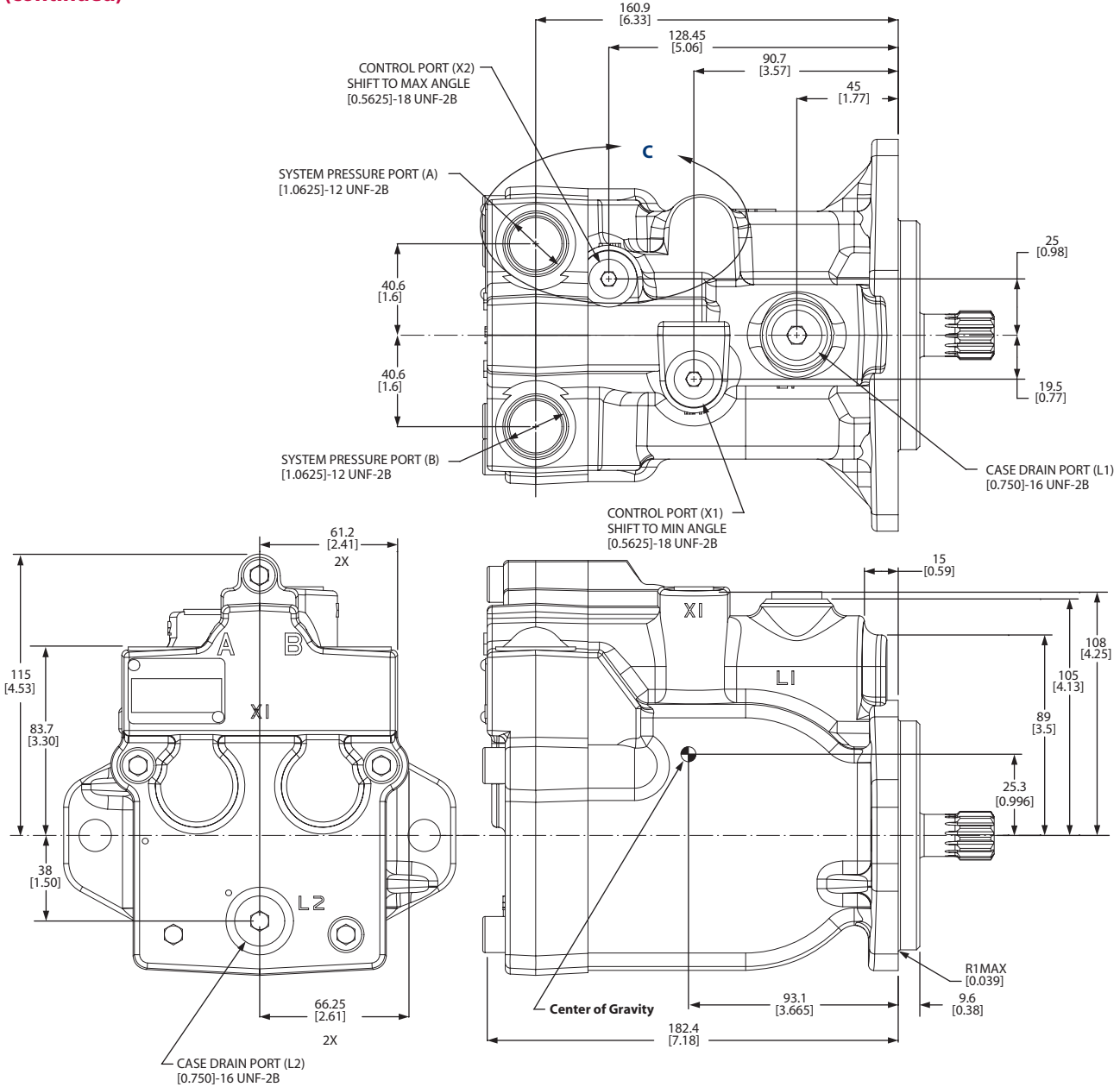

SAE-B MOUNT (LV/KV)
(continued)

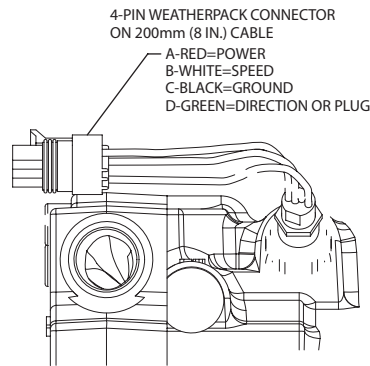

VIEW C
Motor with speed sensor

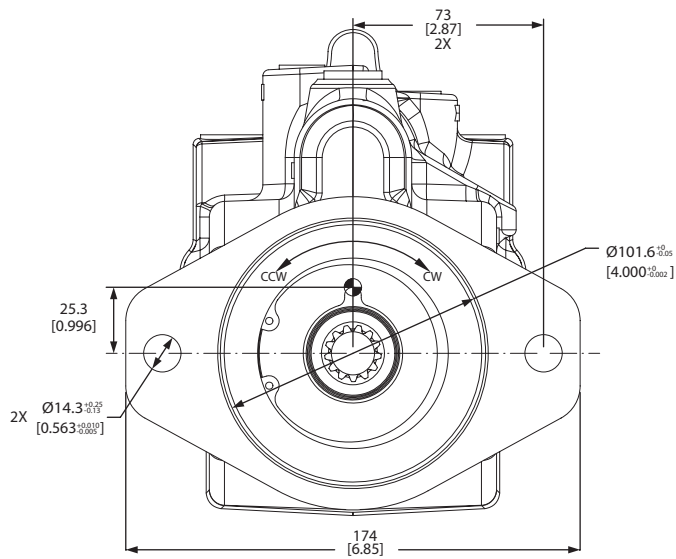

P104 180E

Recommended mounting hardware

Bolt size	Grade	Torque N•m [lbf•ft]
1/2 in.	5	86 [64]
	8	122 [90]

Use hardened washer under each bolt head.

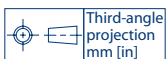

CARTRIDGE (LC/KC)

Radial ports

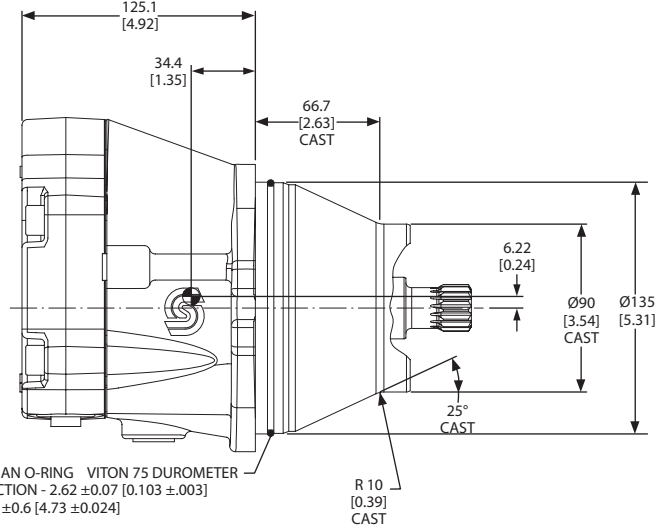
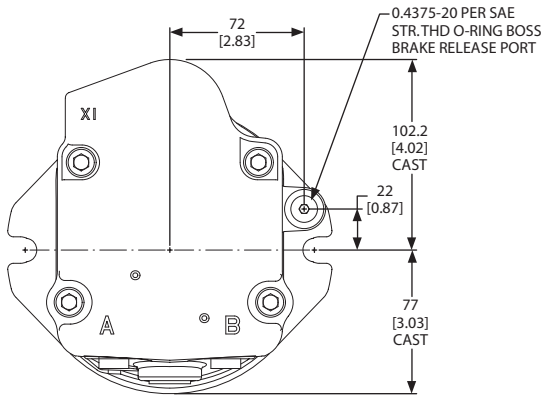

P104 183E

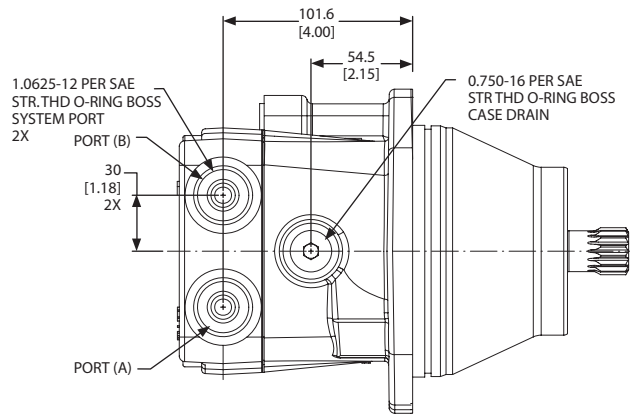

CARTRIDGE (LC/KC)
(continued)

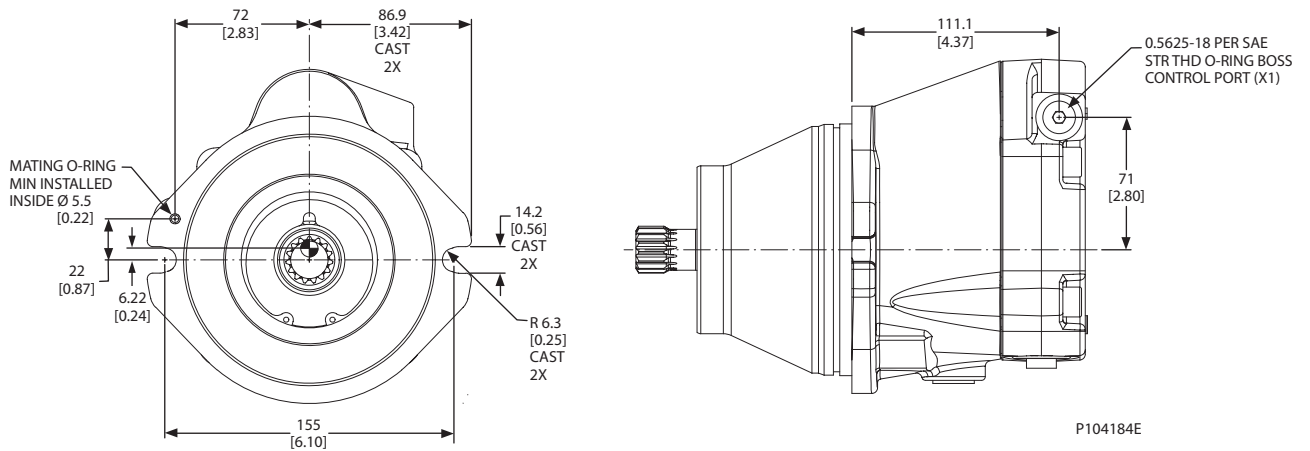

Recommended mounting hardware

Bolt size	Grade	Torque N•m [lbf•ft]	Mounting circle diameter
1/2 in.	5	86 [64]	160 mm [6.299 in]
	8	122 [90]	

Use hardened washer under each bolt head.

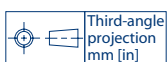



OUR PRODUCTS

- Hydrostatic transmissions
- Hydraulic power steering
- Electric power steering
- Electrohydraulic power steering
- Closed and open circuit axial piston pumps and motors
- Gear pumps and motors
- Bent axis motors
- Orbital motors
- Transit mixer drives
- Planetary compact gears
- Proportional valves
- Directional spool valves
- Cartridge valves
- Hydraulic integrated circuits
- Hydrostatic transaxles
- Integrated systems
- Fan drive systems
- Electrohydraulics
- Microcontrollers and software
- Electric motors and inverters
- Joysticks and control handles
- Displays
- Sensors

Sauer-Danfoss Mobile Power and Control Systems – Market Leaders Worldwide

Sauer-Danfoss is a comprehensive supplier providing complete systems to the global mobile market.

Sauer-Danfoss serves markets such as agriculture, construction, road building, material handling, municipal, forestry, turf care, and many others.

We offer our customers optimum solutions for their needs and develop new products and systems in close cooperation and partnership with them.

Sauer-Danfoss specializes in integrating a full range of system components to provide vehicle designers with the most advanced total system design.

Sauer-Danfoss provides comprehensive worldwide service for its products through an extensive network of Global Service Partners strategically located in all parts of the world.

Local address:

Sauer-Danfoss (US) Company
2800 East 13th Street
Ames, IA 50010, USA
Phone: +1 515 239-6000
Fax: +1 515 239-6618

Sauer-Danfoss GmbH & Co. OHG
Postfach 2460, D-24531 Neumünster
Krokamp 35, D-24539 Neumünster, Germany
Phone: +49 4321 871-0
Fax: +49 4321 871 122

Sauer-Danfoss ApS
DK-6430 Nordborg, Denmark
Phone: +45 7488 4444
Fax: +45 7488 4400

Sauer-Danfoss-Daikin LTD
Sannomiya Grand Bldg. 8F
2-2-21 Isogami-dori, Chuo-ku
Kobe, Hyogo 651-0086, Japan
Phone: +81 78 231 5001
Fax: +81 78 231 5004