

## ORGANIZATION AND HEADINGS

To help you quickly find information in this manual, the material is divided into sections, topics, subtopics, and details, with descriptive headings set in **red type**. Section titles appear at the top of every page in **large red type**. Topic headings appear in the left hand column in **BOLD RED CAPITAL LETTERS**. Subtopic headings appear in the body text in **bold red type** and detail headings in *italic red type*.

References (example: See *Topic xyz*, page XX) to sections, headings, or other publications are also formatted in *red italic type*. In Portable Document Format (PDF) files, these references represent clickable hyperlinks that jump to the corresponding document pages.

## TABLES, ILLUSTRATIONS, AND COMPLEMENTARY INFORMATION

Tables, illustrations, and graphics in this manual are identified by titles set in *blue italic type* above each item. Complementary information such as notes, captions, and drawing annotations are also set in *blue type*.

References (example: See *Illustration abc*, page YY) to tables, illustrations, and graphics are also formatted in *blue italic type*. In PDF files, these references represent clickable hyperlinks that jump to the corresponding document pages.

## SPECIAL TEXT FORMATTING

Defined terms and acronyms are set in **bold black type** in the text that defines or introduces them. Thereafter, the terms and acronyms receive no special formatting.

*Black italic type* is used in the text to emphasize important information, or to set-off words and terms used in an unconventional manner or alternative context. *Red* and *blue italics* represent hyperlinked text in the PDF version of this document (see above).

## TABLE OF CONTENTS

An indented **Table of Contents (TOC)** appears on the next page. Tables and illustrations in the TOC set in *blue type*. In the PDF version of this document, the TOC entries are hyperlinked to the pages where they appear.

© 2006 Sauer-Danfoss. All rights reserved. Printed in U.S.A.

Sauer-Danfoss accepts no responsibility for possible errors in catalogs, brochures and other printed material. Sauer-Danfoss reserves the right to alter its products without prior notice. This also applies to products already ordered provided that such alterations aren't in conflict with agreed specifications. All trademarks in this material are properties of their respective owners. Sauer-Danfoss and the Sauer-Danfoss logotype are trademarks of the Sauer-Danfoss Group.

Front cover illustrations: F101 077, F101 130, F101 128, F101 080, F101 127, F101 131, F101 129, F101 079, F101 084, P101 964

<b>PRODUCT OVERVIEW</b>	Flexibility of design.....	6
	Circuit options .....	6
	Capability .....	6
	Actuation options .....	6
	Modular valves .....	7
	Monoblock valves .....	7
	Features and ratings by model.....	8
<b>QUICK SELECTION MATRIX</b>	Features and ratings by model.....	9
<b>FLUIDS AND FILTRATION</b>	Fluids.....	10
	Base stock and additives .....	10
	Viscosity.....	10
	Filtration.....	10
	Return line filtration.....	10
	Cleanliness.....	10
<b>MODEL 1612</b>	Description .....	11
	Typical applications.....	11
	Standard features .....	11
	Pressure drop.....	12
	Technical data.....	12
	Options .....	12
	Relief valve.....	13
	Handles.....	13
	Dimensions.....	14
<b>MODEL 1617</b>	Description .....	15
	Typical applications.....	15
	Standard features .....	15
	Other features available.....	15
	Pressure drop.....	16
	Technical data.....	16
	Options .....	16
	Dimensions.....	18
	<b>MODEL 1627</b>	Description .....
Typical applications.....		19
Standard features .....		19
Other features available.....		19
Pressure drop.....		20
Technical data.....		20
Options .....		20
Dimensions.....		22

<b>MODEL 1637</b>	Description .....	23
	Typical applications .....	23
	Standard features .....	23
	Other features available .....	23
	Pressure drop .....	24
	Technical data .....	24
	Options .....	24
	Dimensions .....	26
<b>MODEL 1618</b>	Description .....	27
	Typical applications .....	27
	Standard features .....	27
	Pressure drop .....	28
	Technical data .....	28
	Options .....	28
	Dimensions .....	30
<b>CDS 60 AND 100</b>	Specifications .....	31
	Typical performance .....	32
	Inlet covers order code .....	33
	Inlet porting and relief valve options .....	34
	Mid-inlet flow dividers and combiners order code .....	35
	Mid-inlet flow dividers and combiners .....	36
	Outlet covers order code .....	37
	Outlet porting and plug options .....	38
	Work section order code .....	39
	Circuit types .....	42
	Spool types .....	43
	Actuation options .....	44
	Cabling and electrical options for actuator types G, H, and J .....	47
	Actuation mounting side .....	47
	Spool centering and detent options .....	48
	Auxiliary valves .....	50
	Dimensions CDS 100 .....	51
	Dimensions CDS 60 .....	52
<b>MODEL 1125</b>	Typical applications .....	53
	Standard features .....	53
	Pressure drop curves .....	54
	Pressure rise curves(system relief valve SVPR) .....	55
	Pressure rise curves(work port relief valve SVLP) .....	56
	Porting .....	57
	Handles SVM .....	57
	Technical data .....	57
	Options .....	57
	Typical circuit .....	58
	Dimensions .....	59
	Exploded view .....	60



Directional Control Valves  
Technical Information  
Contents

**APPENDIX 1 — ORDER  
FORMS**

Spool valve order form .....	61
CDS60 and CDS100 specification worksheet .....	63
CDS60 and CDS100 price worksheet .....	64
1125 Stack Valve Specifications.....	65
1125 Order Form instructions.....	66

#### FLEXIBILITY OF DESIGN

The Sauer-Danfoss directional control valves are designed to give customer flexibility over a broad range of flow and pressure capabilities. Actuator options include a range of levers, cable actuators, hydraulic and pneumatic pilot controls, two-axis joysticks, and electrohydraulic solenoids. Flow rates range from 0 to 100 l/min [26 US gal/min]. Configurations include compact monoblock and flexible modular styles.

#### CIRCUIT OPTIONS

- Parallel circuits
- Series circuits
- Tandem circuits
- Priority circuits
- Regenerative circuits
- Power beyond
- Open center
- Closed center

#### CAPABILITY

- Flow rates from 0 to 100 l/min [26 US gal/min]
- System pressure up to 240 bar [3500 psi]
- Up to 12 work sections for modular valves
- 12 cm<sup>3</sup>/min [0.7 in<sup>3</sup>/min] leakage (0.5 cm<sup>3</sup>/min [0.03 in<sup>3</sup>/min] for 1618)

#### ACTUATION OPTIONS

- Handles and levers
- Mechanical two-axis joystick
- Exposed or covered spool ends
- **Remote Hydraulic Control (RHC)**
- **ElectroHydraulic Control (EHC)** on/off solenoid
- Cable control
- Hydraulic or pneumatic pilot control
- Dual spool ends

---

Refer to the quick selection matrix on pages 12 and 13 for specific options by model.

---

**MODULAR VALVES**

Valve model	l/min [US gal/min]						Number of Spools	Circuit	Page
CDS-100						100 [26]	1 to 12	Parallel Tandem Series	
CDS-60				60 [16]			1 to 12	Parallel Tandem Series	
1125			38 [10]				1 to 8	Parallel	

**MONOBLOCK VALVES**

Valve model	l/min [US gal/min]						Number of Spools	Circuit	Page
	20 [5]	40 [11]	60 [16]	80 [21]	100 [26]				
1612					76 [20]		1	Tandem	
1617			38 [10]				1	Parallel	
1627			38 [10]				2	Parallel	
1637			38 [10]				3	Parallel	
1618			38 [10]				1	Parallel	

 Indicates Maximum Working Pressure Rated At 210 bar [3000 psi]

**FEATURES AND RATINGS BY MODEL**

Category	Rating / feature	MonoBlock			Modular		
		1617/27/37	1618	1612	1125	CDS60	CDS100
Nominal flow	19 l/min [5 US gal/min]						
	38 l/min [10 US gal/min]	X	X		X		
	57 l/min [15 US gal/min]			X		X	
	76 l/min [20 US gal/min]						
	95 l/min [25 US gal/min]						X
	114 l/min [30 US gal/min]						
Nominal pressure	138 bar [2000 psi]						
	207 bar [3000 psi]	X	X	X	X	X	X
Circuit options	Parallel	X	X		X	X	X
	Series					X	
	Tandem			X		X	X
	Priority				X		
	Power beyond	X	X	X	X	X	X
	Closed center					X	X
Spools	Distance between (mm [in])	28.7 [1.13]	28.7 [1.13]	N/A	35 [1.38]	36 [1.42]	44.5 [1.75]
	Maximum number	3	3	1	8	12	12
Spool action options	Spring center	X	X	X	X	X	X
	1 position detent	X	X	X	X		
	2 position detent	X	X	X	X	X	X
	3 position detent	X	X	X	X	X	X
	Friction detent						
	Float detent	X	X	X		X	X
	Regenerative feel						
	Spring offset	X	X	X	X		
Spool options	3 pos. - 3 way	X	X	X	X	X	X
	3 pos. - 4 way	X	X	X	X	X	X
	4 pos. with float	X		X		X	X
	4 pos. regenerative						
Spool diameter	12.70 mm [0.500 in]						
	15.88 mm [0.625 in]	X	X	X	X		
	19.05 mm [0.75 in]					X	X
	25.40 mm [1.000 in]						
Relief valve options	Ball and spring	X	X	X	X		
	Direct acting poppet					X	X
	Pilot operated	X	X	X	X		
Work port neutral options	Closed to tank	X	X	X	X	X	X
	Open to tank	X	X	X	X	X	X
	Meter to tank	X			X	X	X



**FEATURES AND RATINGS BY MODEL**

Category	Rating / feature	MonoBlock			Modular		
		1617/27/37	1618	1612	1125	CDS60	CDS100
Actuation options	Handle	X	X	X	X	X	X
	Mechanical joystick	X	X			X	X
	Exposed spool end	X	X	X	X	X	X
	Covered spool end				X	X	
	RHC				X	X	X
	EHC on/off					X	X
	Cable control					X	X
	Hydraulic / pneumatic					X	X
	Dual spool ends					X	X
Maximum work port leakage	<1 cm <sup>3</sup> /min [0.061 in <sup>3</sup> /min]		X				
	1 to 3 cm <sup>3</sup> /min [0.061 to 0.183 in <sup>3</sup> /min]						
	4 to 6 cm <sup>3</sup> /min [0.244 to 0.366 in <sup>3</sup> /min]						
	7 to 10 cm <sup>3</sup> /min [0.427 to 0.610 in <sup>3</sup> /min]			X			
	11 to 13 cm <sup>3</sup> /min [0.71 to 0.793 in <sup>3</sup> /min]	X				X	X
	14 to 16 cm <sup>3</sup> /min [0.854 to 0.976 in <sup>3</sup> /min]				X		
	16 to 24 cm <sup>3</sup> /min [0.976 to 1.456 in <sup>3</sup> /min]						
Additional features	Load check	X	X	X	X	X	X
	P.O.check		X		X	X	X
	Flow control					X	X
	Meter in	X	X	X	X		
	Meter out	X		X			
	Hydraulic kickout		X			X	X
	Electric switch	X				X	X

**FLUIDS**

Hydraulic fluid performs three basic functions in a hydraulic system: It transfers energy, lubricates moving components, and transports heat and contaminants out of the system.

**Base stock and additives**

Sauer-danfoss valves are designed to operate with mineral-based fluids containing oxidation, rust, and foam inhibitors, compatible with fluoroelastomer seals. Consult your fluid supplier for information on seal compatibility.

**Viscosity**

Viscosity is the most important property of a hydraulic fluid. It is a measurement of how the fluid resists flow. Low viscosity fluids increase internal leakage; high viscosity fluids increase pressure drop through the valve. Use a fluid that meets the viscosity limits published in this catalog. For specific requirements, see technical data in each section.

**Temperature**

Temperature affects a fluid's viscosity. Higher temperature fluid has lower viscosity. Operating at excessive temperatures may have other detrimental effects on your hydraulic fluid. Design your hydraulic system to operate within the specified temperature range. Specific requirements are published in each section.

**For more information**

For more information on hydraulic fluid selection refer to *Hydraulic Fluids and Lubricants Technical Information*, Sauer-Danfoss publication **520L0463**.

**FILTRATION**

Effective filtration is critical to a hydraulic system's performance and working life. Employ system filtration capable of meeting the published requirements in each valve section. Be aware that other components in the system may have more stringent requirements. Design your filtration system to satisfy the requirements of the most sensitive component.

**Return line filtration**

Return line filtration is generally adequate for Sauer-Danfoss valves. We recommend a 10 micron nominal (20 micron absolute) or finer filter. Insure the filter in your system is properly sized and maintained. To facilitate proper filter maintenance, use a pressure gauge or other indicator to signal when it is necessary to change the filter. Never allow filter to reach its bypass condition. Follow the filter manufacturer's maintenance recommendations.

**Cleanliness**

Hydraulic system contamination must not exceed the limits published for each valve. Limits are specified per ISO 4406 (1999). When measuring system contamination, calibrate test equipment in accordance with the ACFTD method.

For more information

For more information on system filtration, refer to *Design Guidelines for hydraulic fluid cleanliness*, Sauer-Danfoss publication **520L0467**.

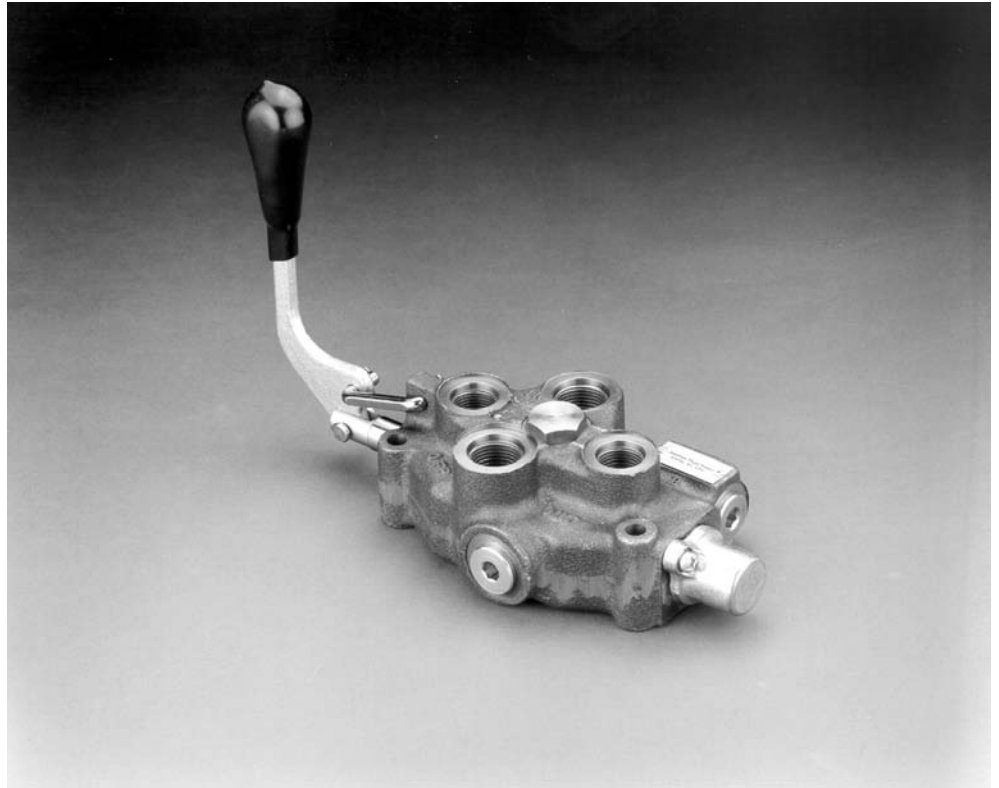
**DESCRIPTION**

Single spool monoblock valve. 76 l/min [20 US gal/min] maximum flow. 207 bar [3000 psi] maximum pressure.

**TYPICAL APPLICATIONS**

Sweepers, mowers, agricultural equipment, auxiliary valves, tree removal equipment

**STANDARD FEATURES**

- All valves supplied with clevis end spools
- Power-beyond port machined and plugged (use whenever a downstream valve is required)
- Cast-iron body
- Chrome plated spools select fit to body for leakage control
- Paint color: black primer
- Load check for each spool to prevent drop before raise
- Individually boxed and labeled

**PRESSURE DROP**

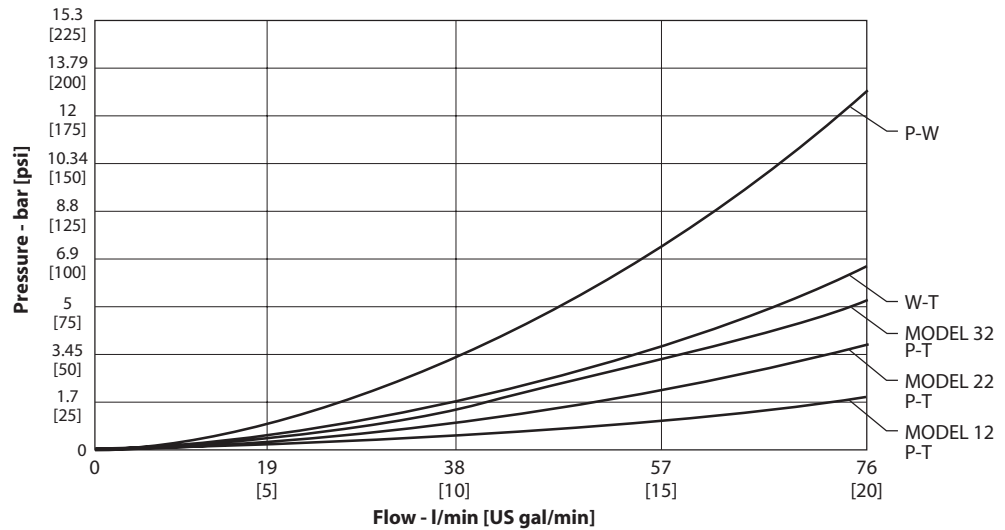

**TECHNICAL DATA**

Maximum pressure	207 bar	[3000 psi]
Maximum tank line pressure	69 bar	[1000 psi]
Maximum oil flow	76 l/min	[20 US gal/min]
Spool travel in and out from neutral	6.3 mm	[0.25 in]
Spool travel to float position from neutral	12.6 mm	[0.50 in]
Maximum port leakage at 69 bar [1000 psi] 21 mm <sup>2</sup> /sec (cSt) [102 SUS]	24 cm <sup>3</sup> /min	[1.46 in <sup>3</sup> /min]
Maximum lift check leakage at 69 bar [1000 psi] 21 mm <sup>2</sup> /sec (cSt) [102 SUS]	82 cm <sup>3</sup> /min	[82 cm <sup>3</sup> /min]
Minimum oil temperature	-29° C	[-20° F]
Maximum oil temperature	82° C	[180° F]
Ambient temperature range	-29° to 60° C	[-20° to 140° F]
Minimum viscosity	6 mm <sup>2</sup> /sec (cSt)	[45 SUS]
Maximum viscosity	440 mm <sup>2</sup> /sec (cSt)	[2000 SUS]
Fluid cleanliness per ISO 4406	19/16	
typical spool effort: dry, full stroke	231 N	[53 lbf]
Weight	3.18 kg	[7 lbs]

**OPTIONS**

*Spool types*

Code	Symbol	Description
T		4-way, 3-position Open center Work ports blocked to tank in neutral position
V		4-way, 3-position Open center B port blocked to tank
F		4-way, 4-position Open center Work ports blocked to tank in neutral position, open to tank in fourth position or float

**OPTIONS**  
 (continued)

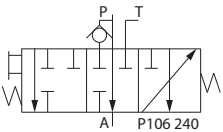
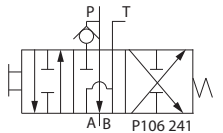
Code	Symbol	Description
<b>X</b>		3-way, 3-position Open center Work port blocked to tank in neutral position
<b>O</b>		4-way, 3-position Motor open center Work ports open to tank in neutral position

*Spool action*

Code	Description	Code	Description
A	Spring centered, detent in float	N	Spring centered, detent in
D	3-position detent	S	Spring centered
L	Spring centered, detent out		

**Relief valve**

- Pilot operated relief valve
- 0.4 bar per liter [20 psi per gallon] rise
- No restrictions on setting up to 207 bar [3000 psi]
- Adjustable standard

*Porting*

<b>Inlet/outlet</b>	7/8-14, SAE (standard) 3/4-16 SAE
<b>Locations available</b>	top and side
<b>Work ports</b>	3/4-16, SAE (standard)

**Handles**

- C-hook kit
- Standard handle with C-hook kit
- Pivot-block handle kit

**DIMENSIONS**

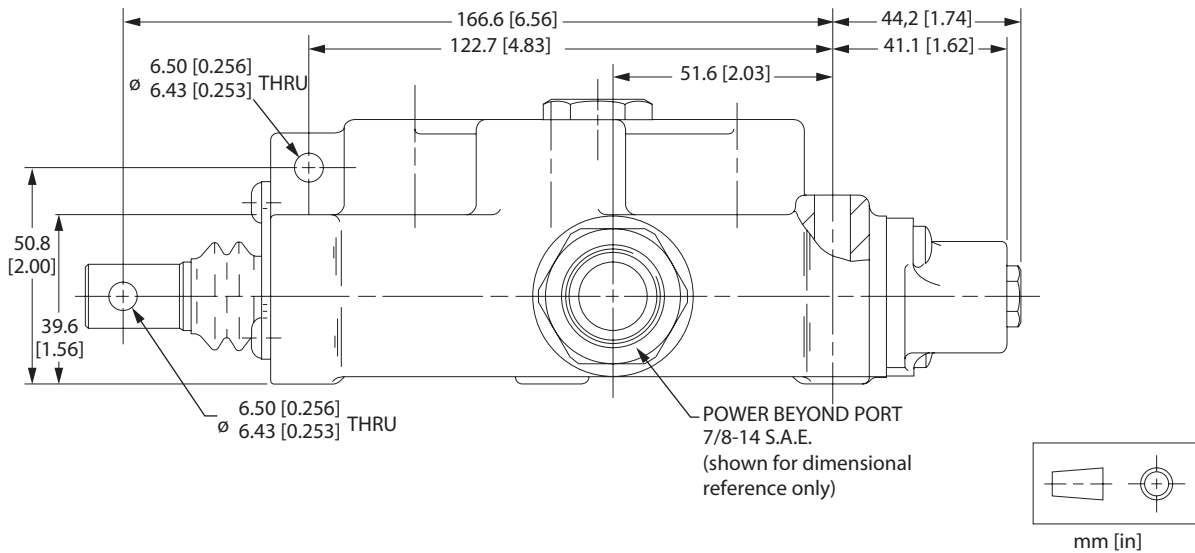
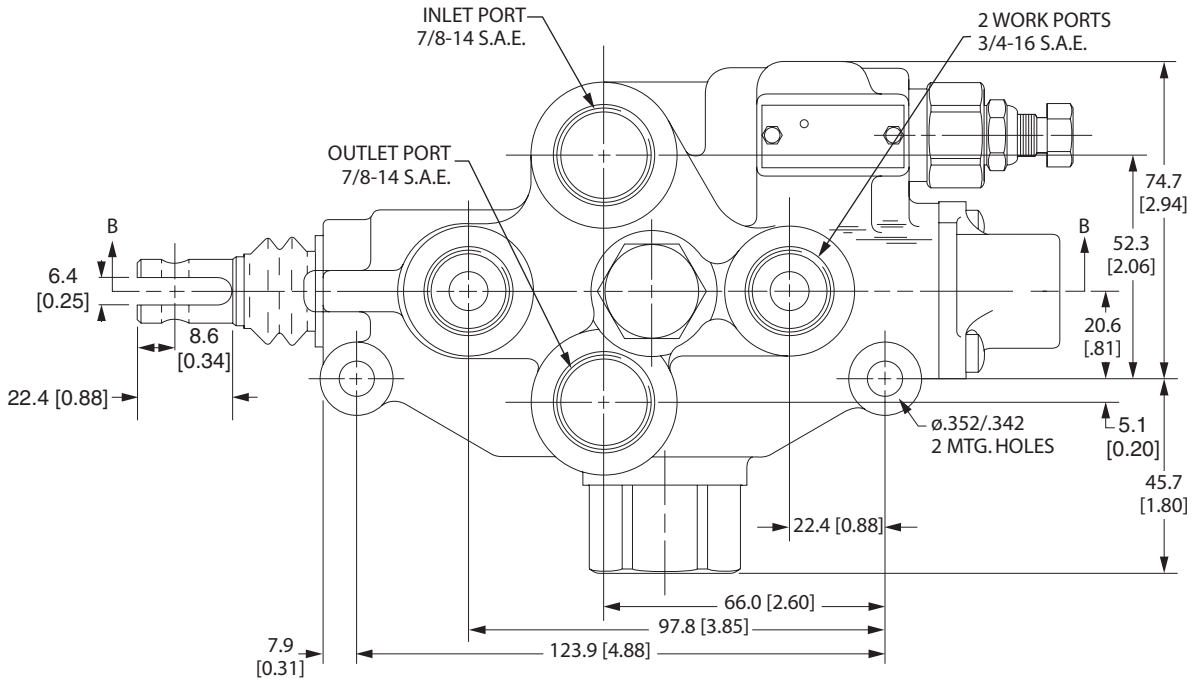

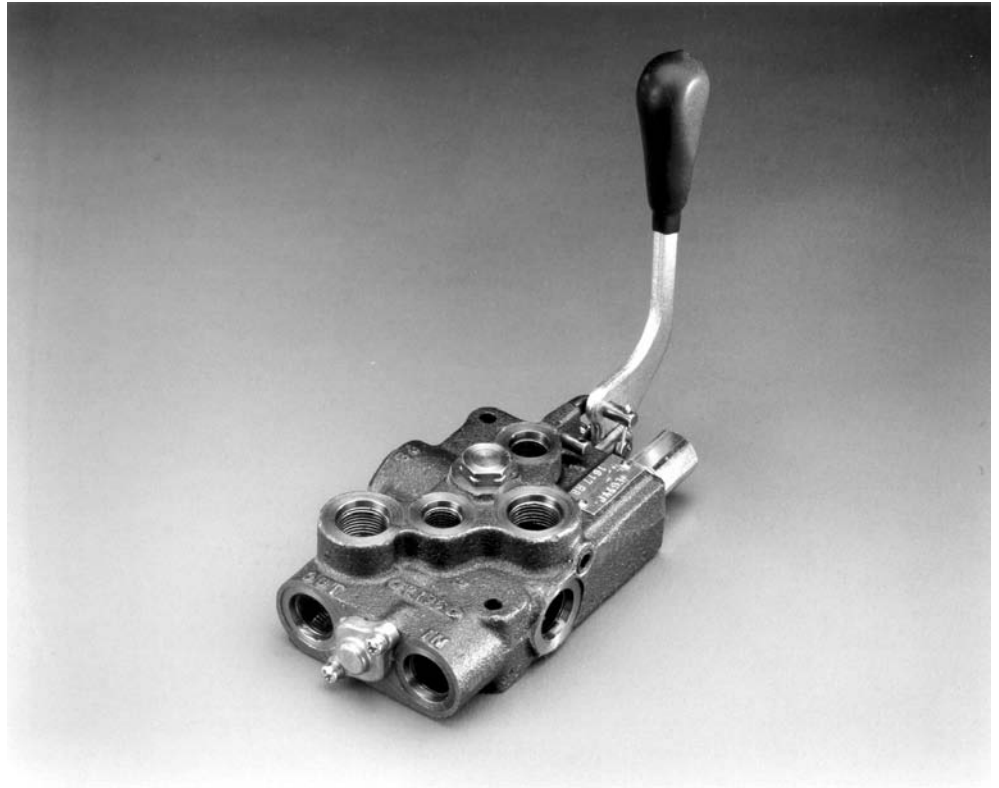
**DESCRIPTION**

Single spool directional control valve with parallel circuitry. 38 l/min [10 US gal/min] maximum flow. 207 bar [3000 psi] maximum pressure.

**TYPICAL APPLICATIONS**

Lawn and garden tractors, mowers, small tractor loader attachments, sweepers, utility trucks, trenchers, agricultural equipment

**STANDARD FEATURES**

- All valves supplied with clevis end spools
- Power-beyond port machined and plugged (use whenever a downstream valve is required)
- Cast-iron body
- Chrome plated spools select fit to body for leakage control
- Paint color: black primer
- Load check for each spool to prevent load drop before raise
- Float conversion (add float detent kit **A** to standard **T** spool)
- Open transition valve
- Individually boxed and labeled

**OTHER FEATURES  
AVAILABLE**

- Tang end spool for cable control
- Unidirectional or bidirectional drop-in work port orifice plates

**PRESSURE DROP**

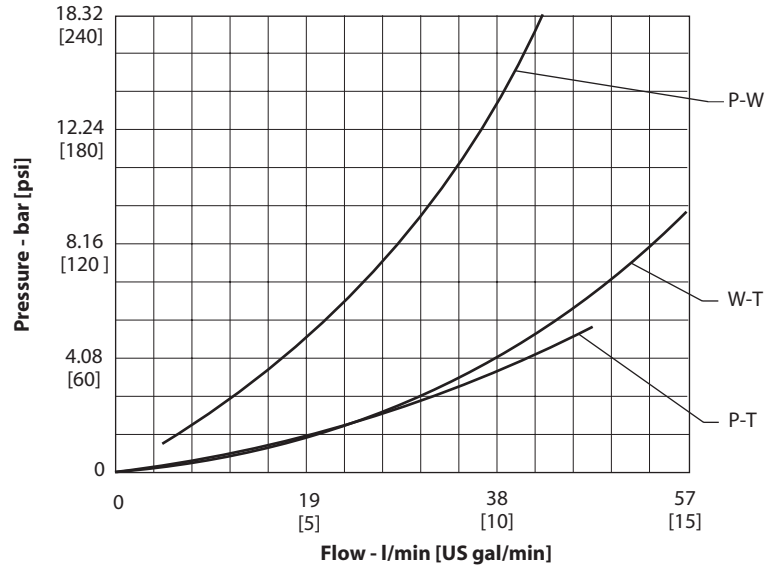

**TECHNICAL DATA**

Maximum pressure	207 bar	[3000 psi]
Maximum tank line pressure	69 bar	[1000 psi]
Maximum oil flow	38 l/min	[10 US gal/min]
Spool travel in and out from neutral	4.8 mm	[0.19 in]
Spool travel to float position from neutral	9.65 mm	[0.38 in]
Maximum port leakage at 69 bar [1000 psi] 21 mm <sup>2</sup> /sec (cSt) [102 SUS]	16 cm <sup>3</sup> /min	[1 in <sup>3</sup> /min]
Maximum lift check leakage at 69 bar [1000 psi] 21 mm <sup>2</sup> /sec (cSt) [102 SUS]	82 cm <sup>3</sup> /min	[5 in <sup>3</sup> /min]
Minimum oil temperature	-29° C	[-20° F]
Maximum oil temperature	82° C	[180° F]
Ambient temperature range	-29° to 60° C	[-20° to 140° F]
Minimum viscosity	6 mm <sup>2</sup> /sec (cSt)	[45 SUS]
Maximum viscosity	440 mm <sup>2</sup> /sec (cSt)	[2000 SUS]
Fluid cleanliness per ISO 4406	19/16	
Typical spool effort: dry, full stroke	231 N	[52 lbf]
Weight	2.26 kg	[5 lbs]

**OPTIONS**

*Spool types*

Code	Symbol	Description
<b>C</b>		4-way, 3-position Closed center Work ports blocked to tank in neutral position
<b>F</b>		4-way, 4-position Open center Work ports blocked to tank in neutral position Open to tank in fourth position or float
<b>O</b>		4-way, 3-position Motor open center Work ports open to tank in neutral position



**OPTIONS**  
 (continued)

Code	Symbol	Description
T		4-way, 3-position Open center Work ports blocked to tank in neutral position
V		3-way, 3-position Open center Work ports blocked to tank in neutral position (B, D, or F)
X		3-way, 3-position Open center Work ports blocked to tank in neutral position (A, C, or E)

*Spool action*

Code	Description	Code	Description
A	Spring centered, detent in float	N	Spring centered, detent in
D	3-position detent	S	Spring centered
L	Spring centered, detent out		

*Relief valve*

Code	Description
2	Direct-acting ball and spring <ul style="list-style-type: none"> <li>• 1 bar/l [50 psi/gal] rise</li> <li>• Standard setting 83 bar [1200 psi] crack pressure at 2.9 l/min [0.75 US gal/min]</li> <li>• Not for use on setting over 30 l/min [8 US gal/min]</li> <li>• Full flow setting at 138 bar [2000 psi]</li> </ul>
3	Pilot operated relief valve <ul style="list-style-type: none"> <li>• 0.4 bar/l [20 psi/gal] rise</li> <li>• No restrictions on setting up to 210 bar [3000 psi]</li> <li>• Standard setting 138 bar [2000 psi] crack pressure at 2.9 l/min [0.75 US gal/min]</li> </ul>

*Porting*

<b>Inlet/outlet</b>	3/4-16, SAE 8
<b>Locations available</b>	inlet-side, top, end outlet-top, end
<b>Work ports</b>	9/16-18, SAE-6

Power-beyond port machined and plugged. (Remove plug and install sleeve for power-beyond feature.)

*Handles*

Code	Description
C	C-hook kit
H	Standard handle with C-hook kit
P	Pivot-block handle kit
N	No handles

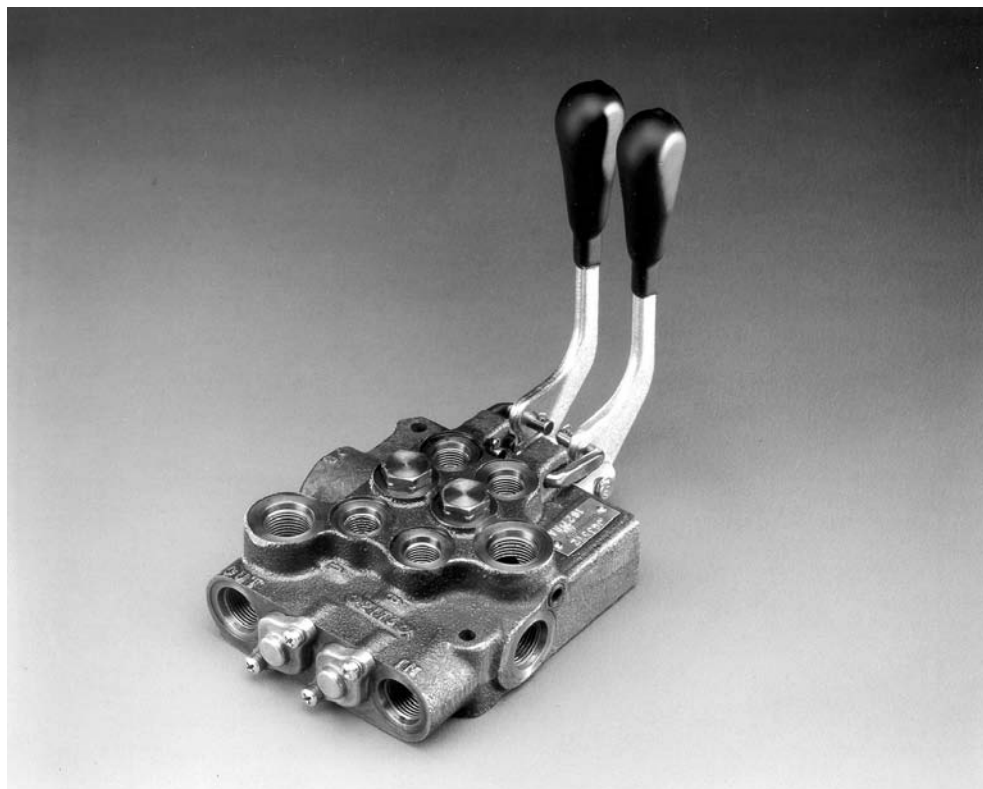

**DESCRIPTION**

Two-spool directional control valve with parallel circuitry. 38 l/min [10 US gal/min] maximum flow. 207 bar [3000 psi] maximum pressure.

**TYPICAL APPLICATIONS**

Lawn and garden tractors, mowers, small tractor loader attachments, sweepers, utility trucks, trenchers, agricultural equipment

**STANDARD FEATURES**

- All valves supplied with clevis end spools
- Power-beyond port machined and plugged (use whenever a downstream valve is required).
- Cast-iron body
- Chrome plated spools select fit to body for leakage control
- Paint color: black primer
- Load-check for each spool to prevent load drop before raise
- Float conversion (add float detent kit **A** to standard **T** spool)
- Open transition valve
- Individually boxed and labeled

**OTHER FEATURES  
AVAILABLE**

- Tang-end spool (for cable control)
- Single handle, mechanical joystick control (model 1627)
- Unidirectional or bidirectional drop-in work port orifice plates
- Range of port sizes

**PRESSURE DROP**

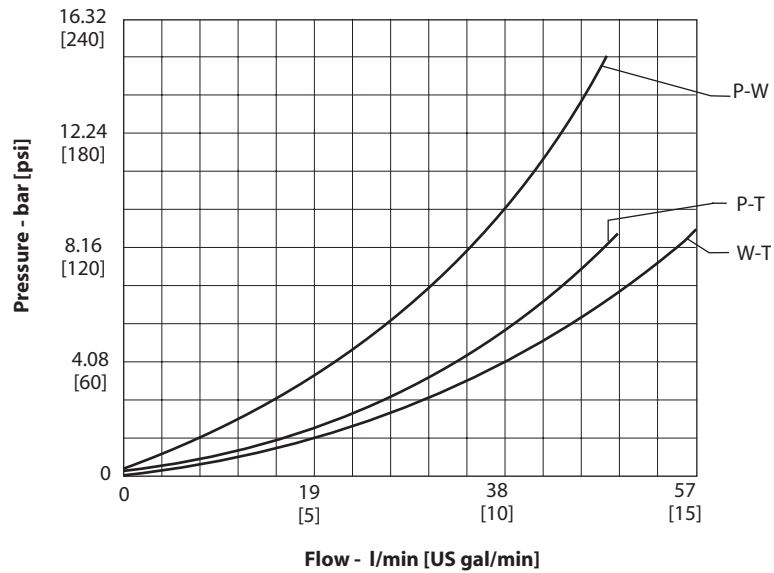

**TECHNICAL DATA**

Maximum pressure	207 bar	[3000 psi]
Maximum tank line pressure	69 bar	[1000 psi]
Maximum oil flow	38 l/min	[10 US gal/min]
Spool travel in and out from neutral	4.8 mm	[0.19 in]
Spool travel to float position from neutral	9.65 mm	[0.38 in]
Maximum port leakage at 69 bar [1000 psi] 21 mm <sup>2</sup> /sec (cSt) [102 SUS]	16 cm <sup>3</sup> /min	[1 in <sup>3</sup> /min]
Maximum lift check leakage at 69 bar [1000 psi] 21 mm <sup>2</sup> /sec (cSt) [102 SUS]	82 cm <sup>3</sup> /min	[5 in <sup>3</sup> /min]
Minimum oil temperature	-29° C	[-20° F]
Maximum oil temperature	82° C	[180° F]
Ambient temperature range	-29° to 60° C	[-20° to 140° F]
Minimum viscosity	6 mm <sup>2</sup> /sec (cSt)	[45 SUS]
Maximum viscosity	440 mm <sup>2</sup> /sec (cSt)	[2000 SUS]
Fluid cleanliness per ISO 4406	19/16	
Typical spool effort: dry, full stroke	231 N	[52 lbf]
Weight	3.62 kg	[8 lbs]

*Spool types*

**OPTIONS**

Code	Symbol	Description
<b>C</b>		4-way, 3-position Closed center Work ports blocked to tank in neutral position
<b>F</b>		4-way, 4-position Open center Work ports blocked to tank in neutral position Open to tank in fourth position or float
<b>O</b>		4-way, 3-position Motor open center Work ports open to tank in neutral position

**OPTIONS**  
 (continued)

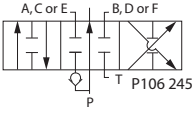
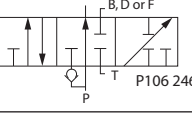
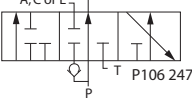
Code	Symbol	Description
T		4-way, 3-position Open center Work ports blocked to tank in neutral position
V		3-way, 3-position Open center Work ports blocked to tank in neutral position (B, D, or F)
X		3-way, 3-position Open center Work ports blocked to tank in neutral position (A, C, or E)

*Spool action*

Code	Description	Code	Description
A	Spring centered, detent in float	N	Spring centered, detent in
D	3-position detent	S	Spring centered
L	Spring centered, detent out		

*Relief valve*

Code	Description
2	Direct-acting ball and spring <ul style="list-style-type: none"> <li>• 1 bar/l [50 psi/gal] rise</li> <li>• Standard setting 83 bar [1200 psi] crack pressure at 2.9 l/min [0.75 US gal/min]</li> <li>• Not for use on setting over 30 l/min [8 US gal/min]</li> <li>• Full flow setting at 138 bar [2000 psi]</li> </ul>
3	Pilot operated relief valve <ul style="list-style-type: none"> <li>• 0.4 bar/l [20 psi/gal] rise</li> <li>• No restrictions on setting up to 210 bar [3000 psi]</li> <li>• Standard setting 138 bar [2000 psi] crack pressure at 2.9 l/min [0.75 US gal/min]</li> </ul>

*Porting*

<b>Inlet/outlet</b>	3/4-16, SAE 8
<b>Locations available</b>	inlet-side, top, end outlet-top, end
<b>Work ports</b>	9/16-18, SAE-6

Power-beyond port machined and plugged. (Remove plug and install sleeve for power-beyond feature.)

*Handles*

Code	Description
C	C-hook kit
F	Joystick (option)
H	Standard handle with C-hook kit
P	Pivot-block handle kit
N	No handles

**DIMENSIONS**

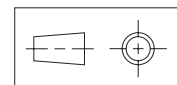
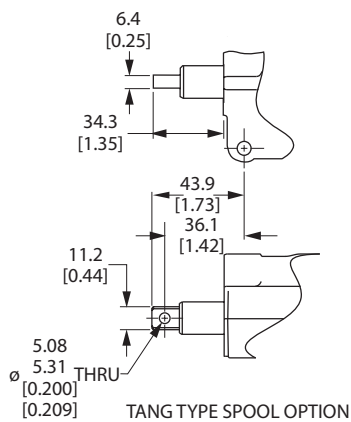
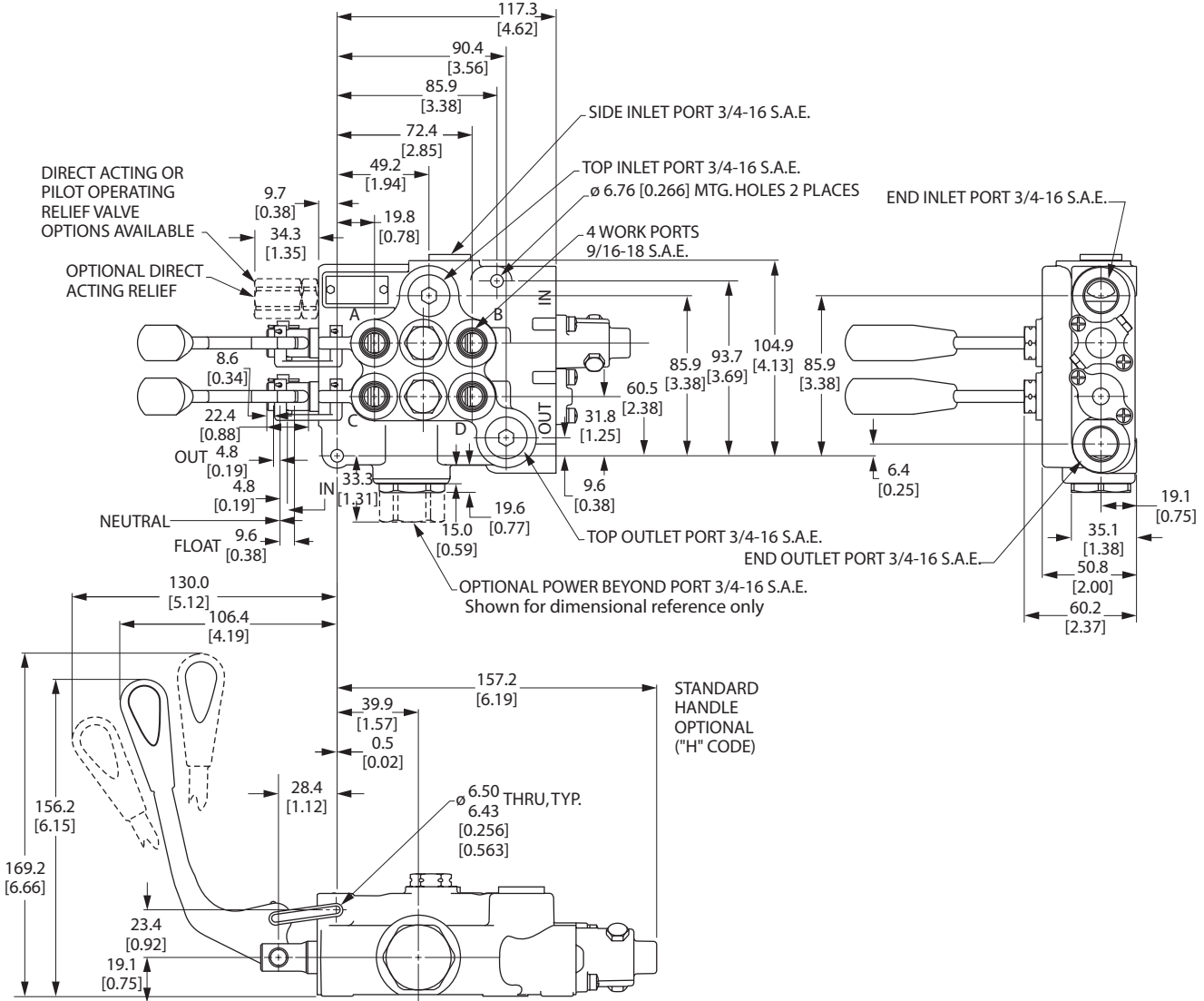

mm [in]

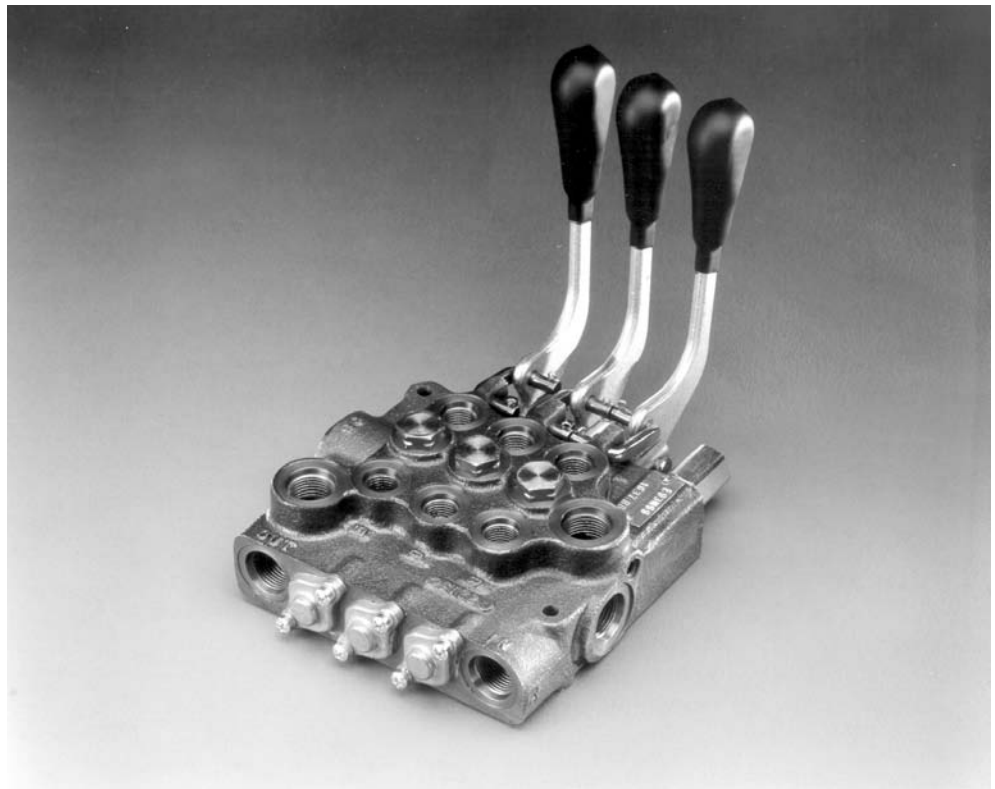
**DESCRIPTION**

Three spool directional control valve with parallel circuitry. 38 l/min [10 US gal/min] maximum flow. 207 bar [3000 psi] maximum pressure.

**TYPICAL APPLICATIONS**

Lawn and garden tractors, mowers, small tractor loader attachments, sweepers, utility trucks, trenchers, agricultural equipment

**STANDARD FEATURES**

- All valves supplied with clevis end spools
- Power-beyond port machined and plugged (use whenever a downstream valve is required).
- Cast-iron body
- Chrome plated spools select fit to body for leakage control
- Paint color: black primer
- Load-check for each spool to prevent load drop before raise
- Float conversion (add float detent kit **A** to standard **T** spool)
- Open transition valve
- Individually boxed and labeled

**OTHER FEATURES  
AVAILABLE**

- Tang-end spool (for cable control)
- Unidirectional or bidirectional drop-in work port orifice plates

**PRESSURE DROP**

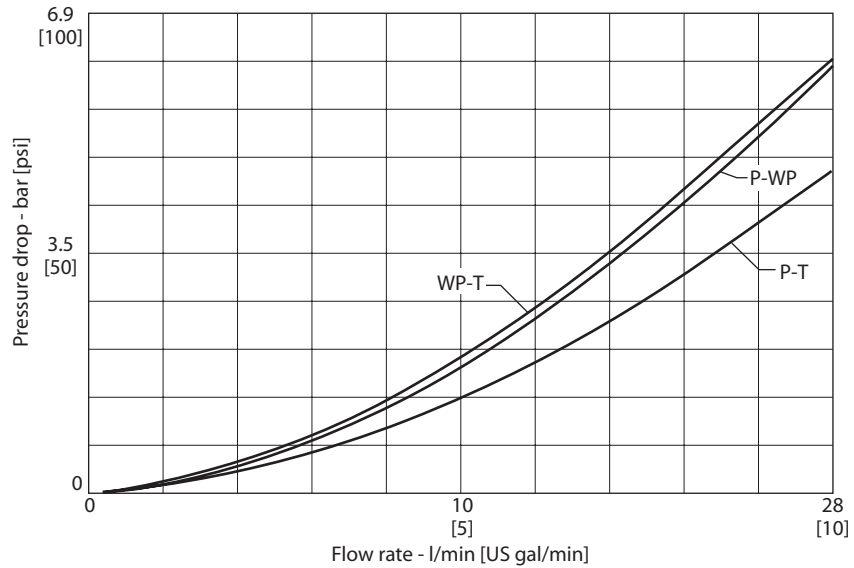

**TECHNICAL DATA**

Maximum pressure	207 bar	[3000 psi]
Maximum tank line pressure	69 bar	[1000 psi]
Maximum oil flow	38 l/min	[10 US gal/min]
Spool travel in and out from neutral	4.8 mm	[0.19 in]
Spool travel to float position from neutral	9.65 mm	[0.38 in]
Maximum port leakage at 69 bar [1000 psi] 21 mm <sup>2</sup> /sec (cSt) [102 SUS]	16 cm <sup>3</sup> /min	[1 in <sup>3</sup> /min]
Maximum lift check leakage at 69 bar [1000 psi] 21 mm <sup>2</sup> /sec (cSt) [102 SUS]	82 cm <sup>3</sup> /min	[5 in <sup>3</sup> /min]
Minimum oil temperature	-29° C	[-20° F]
Maximum oil temperature	82° C	[180° F]
Ambient temperature range	-29° to 60° C	[-20° to 140° F]
Minimum viscosity	6 mm <sup>2</sup> /sec (cSt)	[45 SUS]
Maximum viscosity	440 mm <sup>2</sup> /sec (cSt)	[2000 SUS]
Fluid cleanliness per ISO 4406	19/16	
Typical spool effort: dry, full stroke	231 N	[52 lbf]
Weight	5.44 kg	[12 lbs]

**OPTIONS**

*Spool types*

Code	Symbol	Description
<b>C</b>		4-way, 3-position Closed center Work ports blocked to tank in neutral position
<b>O</b>		4-way, 3-position Motor open center Work ports open to tank in neutral position
<b>T</b>		4-way, 3-position Open center Work ports blocked to tank in neutral position

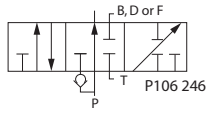
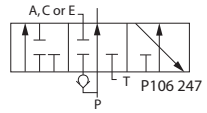

**OPTIONS**  
 (continued)

Code	Symbol	Description
V		3-way, 3-position Open center Work ports blocked to tank in neutral position (B, D, or F)
X		3-way, 3-position Open center Work ports blocked to tank in neutral position (A, C, or E)

*Spool action*

Code	Description	Code	Description
A	Spring centered, detent in float	N	Spring centered, detent in
D	3-position detent	S	Spring centered
L	Spring centered, detent out		

*Relief valve*

Code	Description
2	Direct-acting ball and spring <ul style="list-style-type: none"> <li>• 1 bar/l [50 psi/gal] rise</li> <li>• Standard setting 83 bar [1200 psi] crack pressure at 2.9 l/min [0.75 US gal/min]</li> <li>• Not for use on setting over 30 l/min [8 US gal/min]</li> <li>• Full flow setting at 138 bar [2000 psi]</li> </ul>
3	Pilot operated relief valve <ul style="list-style-type: none"> <li>• 0.4 bar/l [20 psi/gal] rise</li> <li>• No restrictions on setting up to 210 bar [3000 psi]</li> <li>• Standard setting 138 bar [2000 psi] crack pressure at 2.9 l/min [0.75 US gal/min]</li> </ul>

*Porting*

<b>Inlet/outlet</b>	3/4-16, SAE 8
<b>Locations available</b>	inlet-side, top, end outlet-top, end
<b>Work ports</b>	9/16-18, SAE-6

Power-beyond port machined and plugged. (Remove plug and install sleeve for power-beyond feature.)

*Handles*

Code	Description
C	C-hook kit
H	Standard handle with C-hook kit
P	Pivot-block handle kit
N	No handles

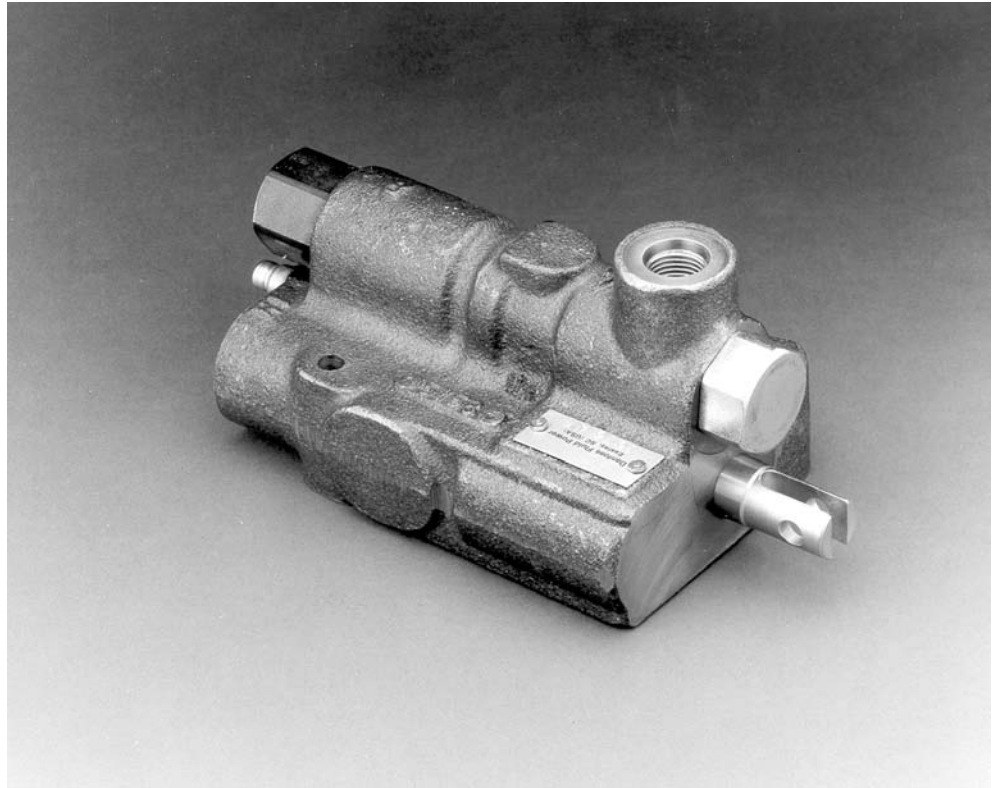

**DESCRIPTION**

Single spool monoblock valve. 38 l/min [10 US gal/min] maximum flow. 207 bar [3000 psi] maximum pressure.

**TYPICAL APPLICATIONS**

Mowers, sweepers, fork lifts, aerial lift equipment, utility trucks, snow blades, trenchers, agricultural equipment

**STANDARD FEATURES**

- All valves supplied with clevis end spools
- Power-beyond port machined and plugged (use whenever a downstream valve is required)
- Cast-iron body
- Chrome plated spools select fit to body for leakage control
- Pilot operated checks for low leakage
- Paint color: black primer
- Closed transition spool timing prevents load drop before raise
- Individually boxed and labeled

**PRESSURE DROP**

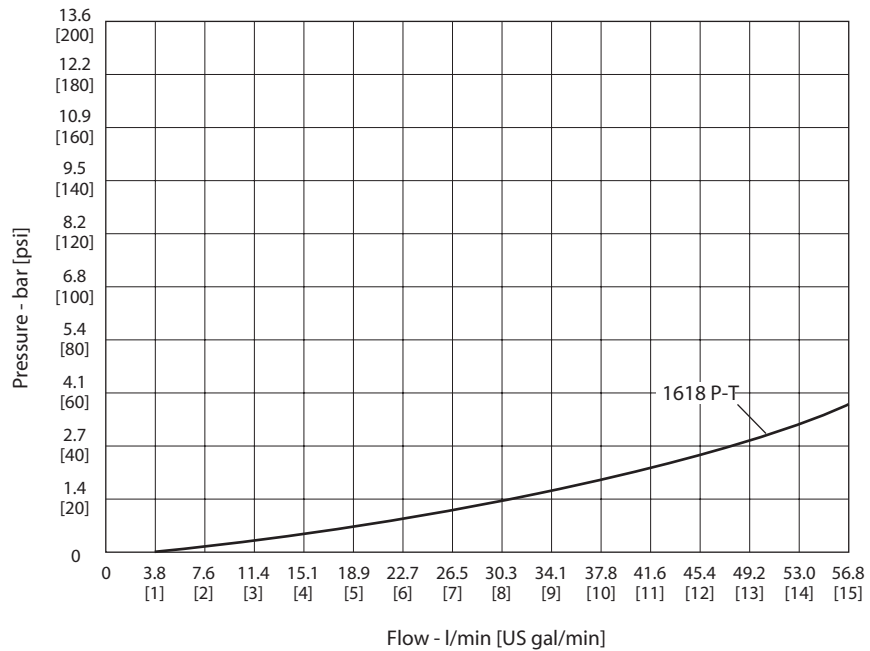

**TECHNICAL DATA**

<b>Maximum pressure</b>	207 bar	[3000 psi]
<b>Maximum tank line pressure</b>	69 bar	[1000 psi]
<b>Maximum oil flow</b>	38 l/min	[10 US gal/min]
<b>Spool travel in and out from neutral</b>	4.8 mm	[0.19 in]
<b>Maximum standby leakage @ 69 bar [1000 psi] 21 mm<sup>2</sup>/sec (cSt) [102 SUS]</b>	300 cm <sup>3</sup> /min	[18 in <sup>3</sup> /min]
<b>Standard pilot check leakage @ 69 bar [1000 psi] 21 mm<sup>2</sup>/sec (cSt) [102 SUS]</b>	0.5 cm <sup>3</sup> /min	[0.03 in <sup>3</sup> /min]
<b>Minimum oil temperature</b>	-29° C	[-20° F]
<b>Maximum oil temperature</b>	82° C	[180° F]
<b>Ambient temperature range</b>	-29° to 60° C	[-20° to 140° F]
<b>Minimum viscosity</b>	6 mm <sup>2</sup> /sec (cSt)	[45 SUS]
<b>Maximum viscosity</b>	440 mm <sup>2</sup> /sec (cSt)	[2000 SUS]
<b>Fluid cleanliness per ISO 4406</b>	19/16	
<b>Typical spool effort: dry, full stroke</b>	231 N	[52 lbf]
<b>Weight</b>	2.72 kg	[6 lbs]

**OPTIONS**

*Spool types*

Code	Symbol	Description
O		4-way, 3-position Motor open center Work ports open to tank in neutral position

**OPTIONS**  
 (continued)

*Spool action*

Code	Description	Code	Description
A	Spring centered, detent in float	N	Spring centered, detent in
D	3-position detent	S	Spring centered
L	Spring centered, detent out		

*Relief valve*

Code	Description
3	Pilot operated relief valve <ul style="list-style-type: none"> <li>• 0.4 bar/l [20 psi/gal] rise</li> <li>• No restrictions on setting up to 210 bar [3000 psi]</li> <li>• Standard setting 138 bar [2000 psi] crack pressure at 2.9 l/min [0.75 US gal/min]</li> </ul>

*Porting*

<b>Inlet/outlet</b>	9/16 -18 SAE, 3/4 - 6 SAE
<b>Locations available</b>	side, end B/D ports - end A/C ports - top, end
<b>Work ports</b>	9/16 -18 SAE

---

Power-beyond port machined and plugged. (Remove plug and install sleeve for power-beyond feature.)

---

*Handles*

Code	Description
N	No handles

**DIMENSIONS**

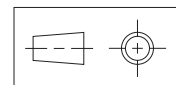
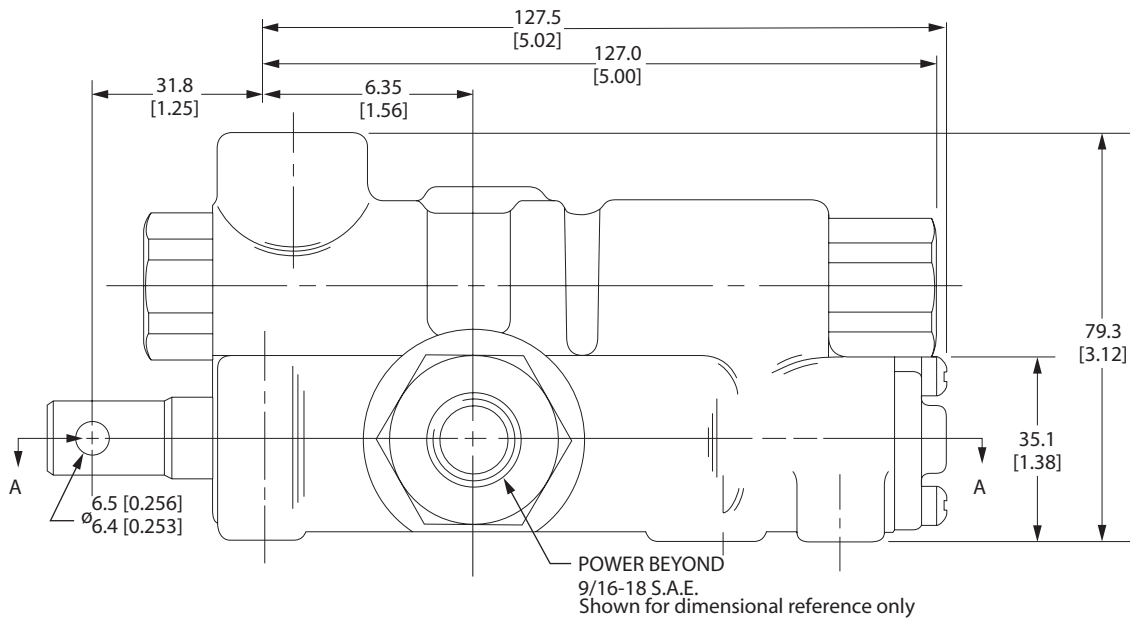
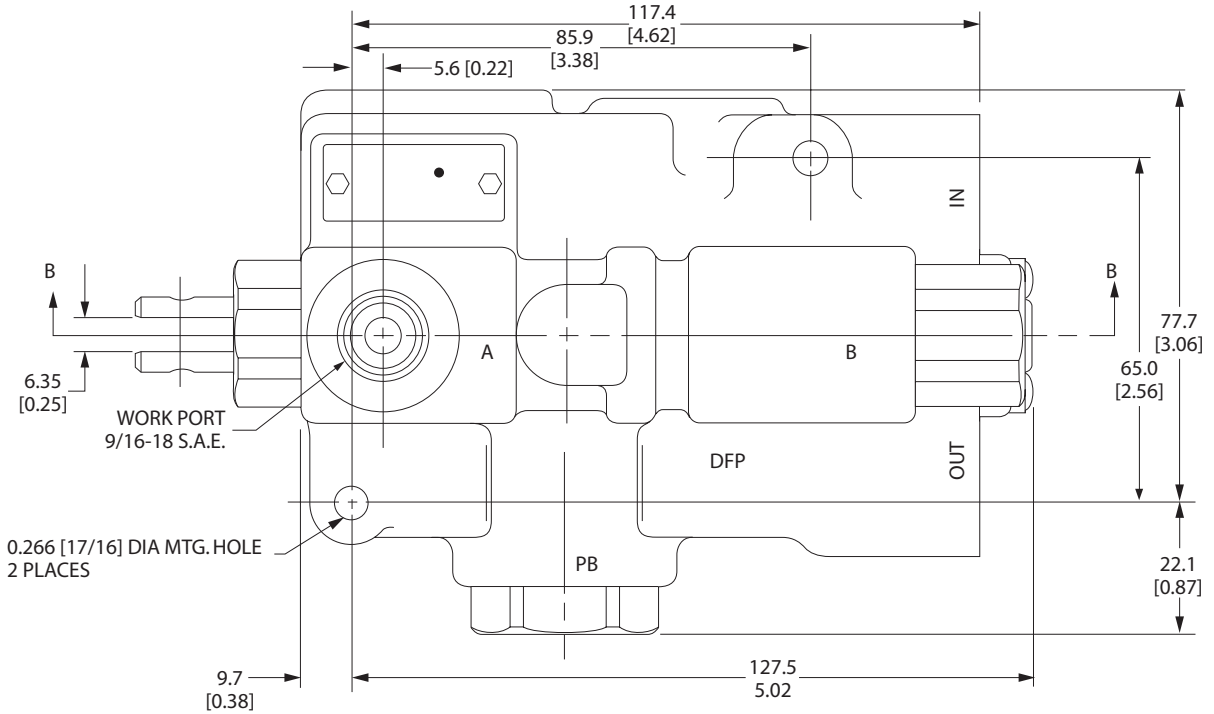

mm [in]

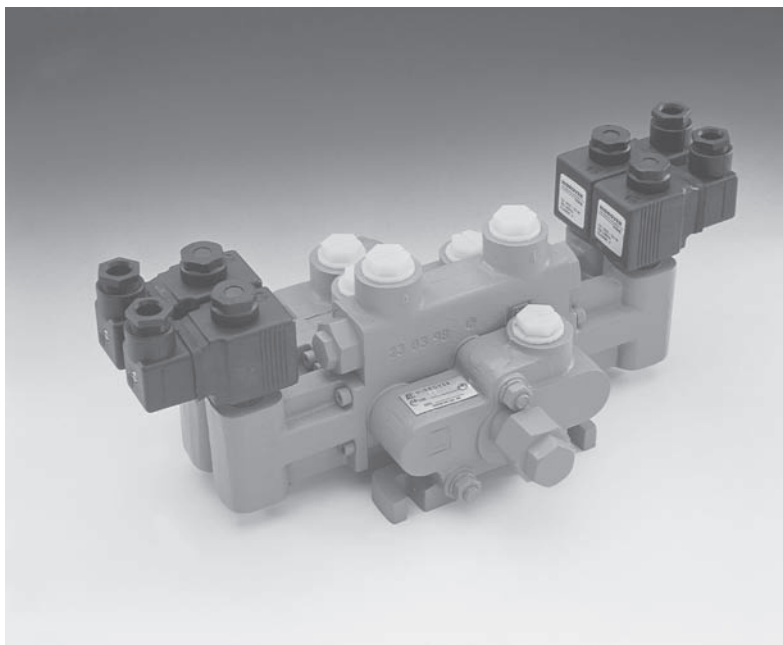

CDS 100

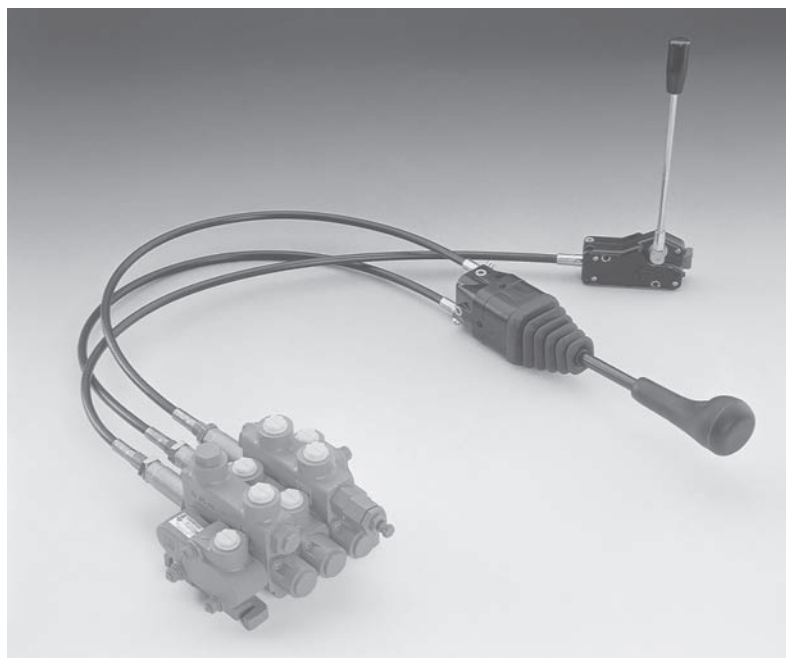

CDS 60

**SPECIFICATIONS**

<b>Maximum flow (CDS 100)</b>	100 l/min [26.4 US gal/min]
<b>Maximum flow (CDS 60)</b>	60 l/min [15.8 US gal/min]
<b>Work pressure</b>	210 bar [3050 psi]
<b>Maximum pressure</b>	250 bar [3625 psi]
<b>Maximum pressure (outlet section)</b>	40 bar [580 psi]
<b>Temperature range</b>	-40° to 80° C [-40 to 176° F]
<b>Recommended fluid type</b>	Mineral based hydraulic oil
<b>Recommended viscosity</b>	26-55 mm <sup>2</sup> /sec (cSt) [123-255 SUS]
<b>Minimum fluid cleanliness (per ISO 4406)</b>	19/16

**TYPICAL PERFORMANCE**

Based on oil temperature of 45°–50°C [113°–122° F]. Viscosity 32 mm<sup>2</sup>/sec (cSt) [151 SUS]. CDS spool leakage (standard) at 70 bar [1015 psi], 50°C [122°F], ISO VG46: 10 cm<sup>3</sup>/min [0.61 in<sup>3</sup>/min]

*Pressure vs. flow curves for main relief valve*

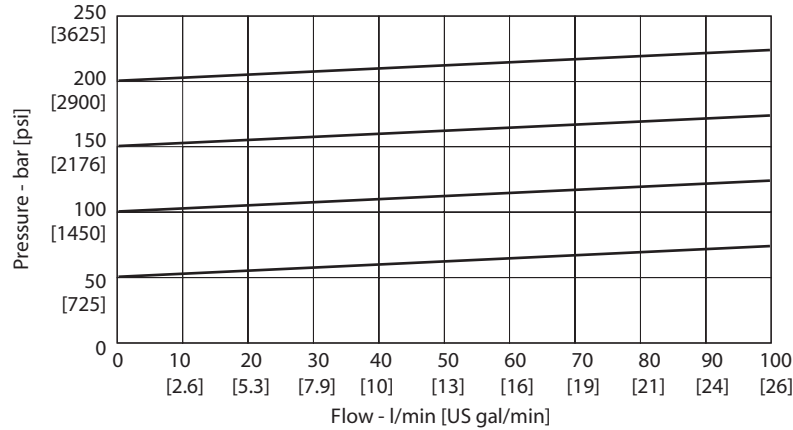

*Pressure drop (P-T) CDS 60*

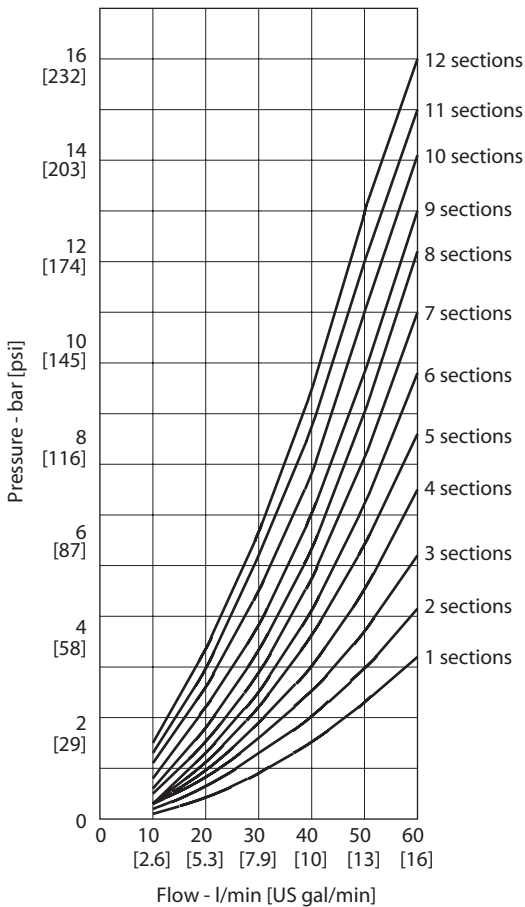

*Pressure drop (P-T) CDS 100*

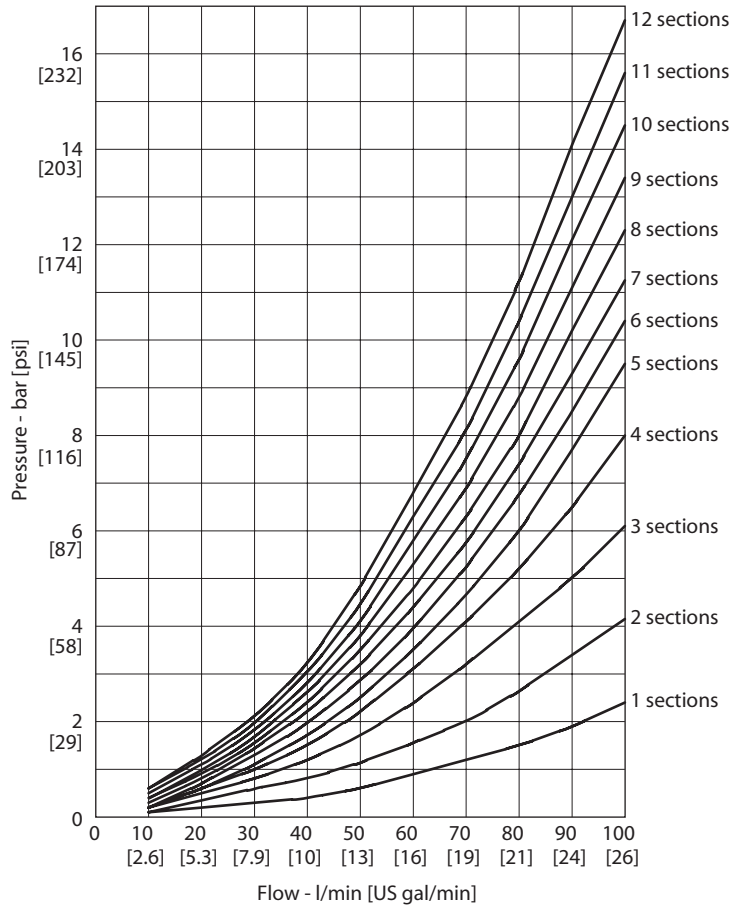



**INLET COVERS ORDER CODE**

Inlet covers order code (example)

**E60 A C 2 140/40\***

*Models*

Code	Description
E100	CDS100
P100	CDS100 with priority flow control (contact Sauer-Danfoss)
E60	CDS60
P60	CDS60 with priority flow control (contact Sauer-Danfoss)

*Port locations*

Code	Description
A	Top port
B	Side port, top port plugged
C	Top port, with side gauge port (1/4-in NPT)
D	Top inlet and outlet ports (use H, I, J on outlet)

*Main relief valves*

Code	Description
A	No valve, with plastic plug
B	No valve, with special plug
C	Valve, with direct valve and external adjustment
D	Valve, with direct valve and internal adjustment

*Port types*

Code		1	2	3	4	5	6	7	8	9	X
Threads		SAE - ORB			BSP - Parallel			Metric - ISO 6149			Special porting, specify
		#8 3/4 -16UNF	#10 7/8 -14UNF	#12 1 1/16-12UNF	3/8 -19	1/2 -14	3/4 -14	M18x1.5	M22x1.5	M27x2	
Model CDS100	Inlet outlet		●	●		●	●		●	●	
	Section		●	●		●	●		●	●	
Model CDS60	Inlet outlet	●	●		●	●		●	●		
	Section	●	●		●	●		●	●		

● available

Note: At this time, North America only stocks SAE-Oring boss.

\* Default relief setting if not specified

**INLET PORTING AND RELIEF VALVE OPTIONS**

Inlet covers order code (example)

**E60 A C 2 140/40\***

Port location

- D** Top inlet and outlet (use with H,I,J, and L outlet covers)
- A** Top inlet
- C** Top inlet, gauge port side (1/4 in NPT)
- B** Side inlet (top plugged)

E100 inlet cover

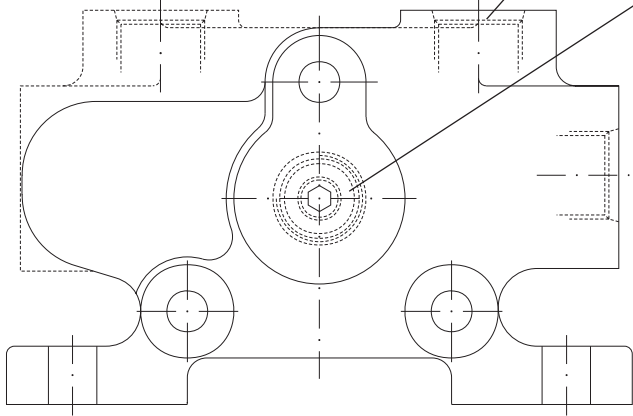

E60 inlet cover

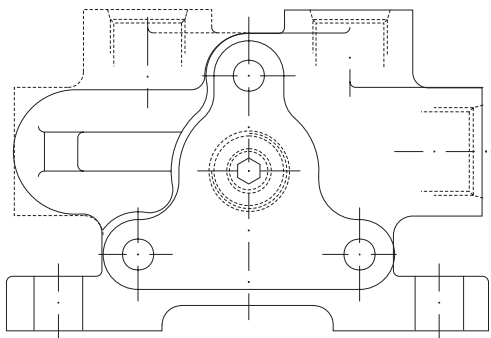

P101 798

Relief valve

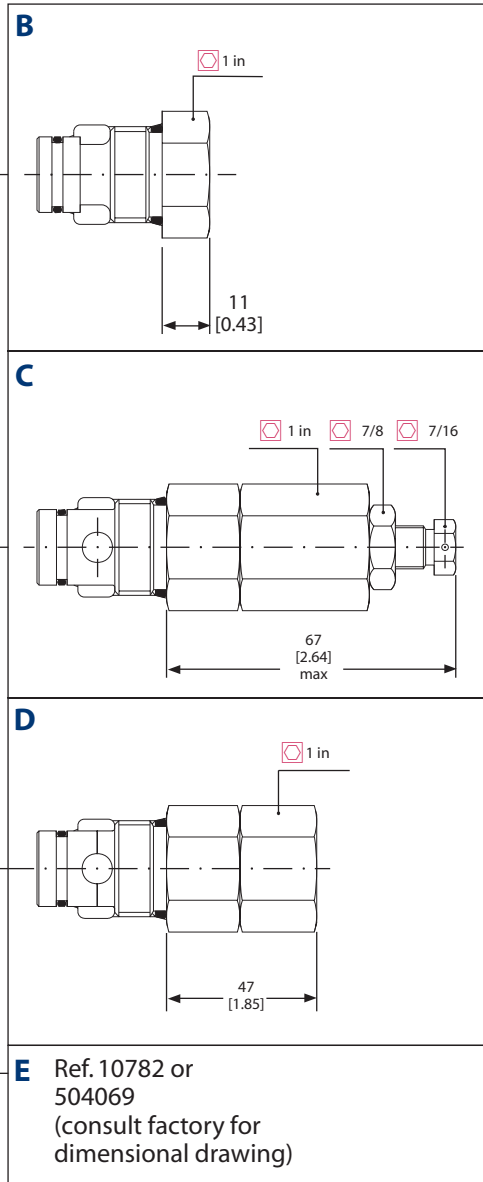

mm [in]

\* Default relief setting if not specified

**MID-INLET FLOW  
 DIVIDERS AND  
 COMBINERS ORDER  
 CODE**

Mid-Inlet flow dividers/combiners order code (example)

**I60 1 2 2 140/40\***

*Models*

Code	Description
I60	CDS 60 mid-inlet
I100	CDS100 mid-inlet

*Mid-inlet type*

Code	Description
1	Flow divider
2	Flow combiner

*Port types*

Code		1	2	3
Threads		SAE - ORB		
		#8 3/4 -16UNF	#10 7/8 -14UNF	#12 1 1/16-12UNF
Model CDS100	Mid-inlet		●	●
Model CDS60	Mid-inlet	●	●	

● available

*Main relief valves*

Code	Description
1	Plug
2	CDS 60 relief
3	CDS 100 relief

Note: At this time, North America only stocks SAE-Oring boss.

\* Default relief setting if not specified

**MID-INLET FLOW  
DIVIDERS AND  
COMBINERS**

*Min-inlet flow combiner*

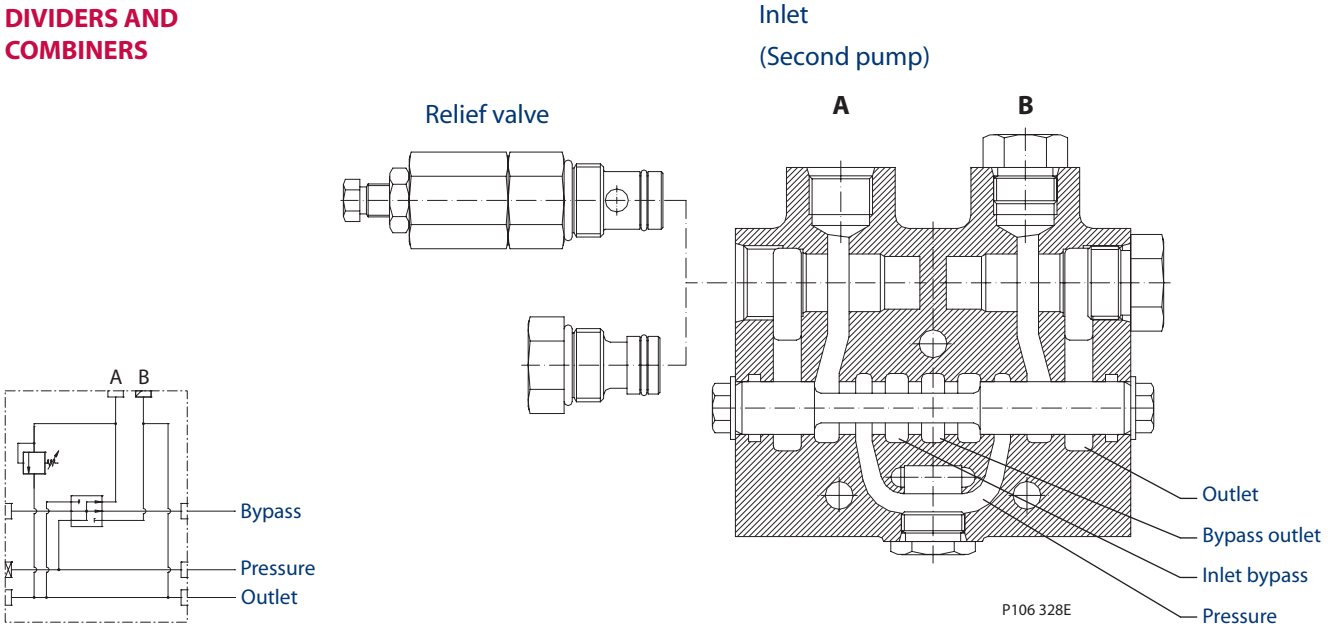

*Min-inlet flow divider*

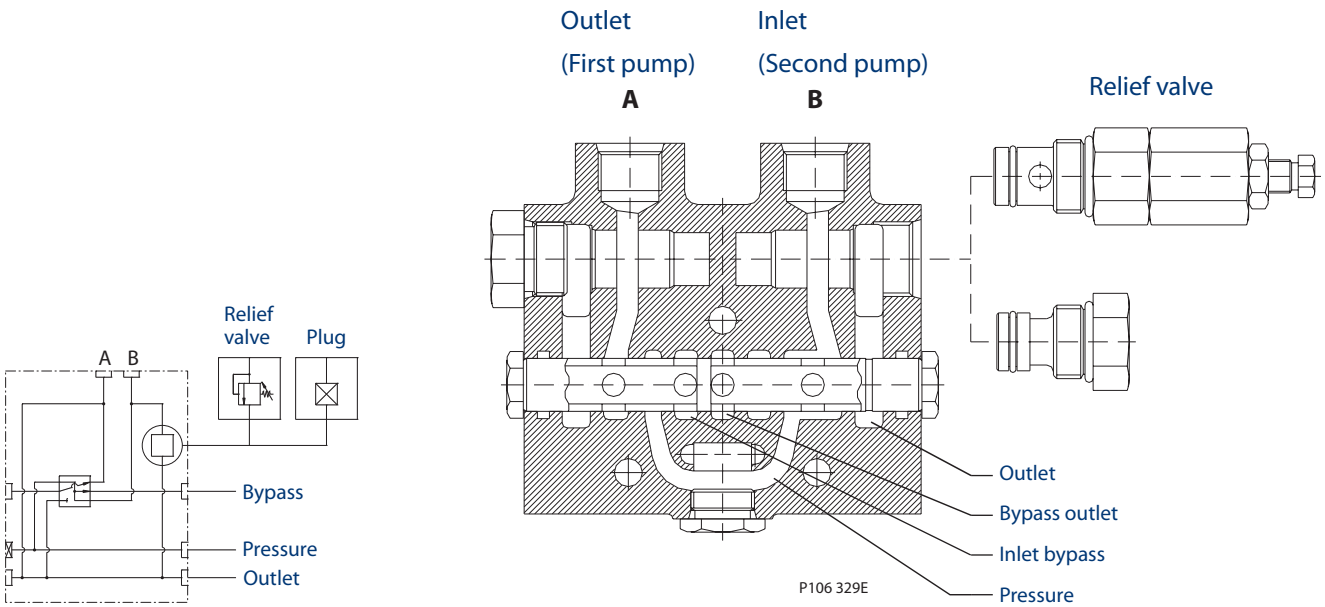

**OUTLET COVERS ORDER CODE**

Outlet covers order code (example)

**S60 A 2**

*Models*

Code	Description
S100	CDS 100
S60	CDS 60

*Ports*

Code	Description
A	Top outlet
B	Side outlet, top plugged
C	Side outlet for power beyond (top to tank)
D	Top outlet (with closed bypass)
E	Top outlet (for electrical control)
F	Top outlet (for electrical control, with power beyond)
G	Side outlet (for electrical control, top plugged)
H	Top plugged
I	Top plugged, use with power beyond
J	Top plugged for electrical control
L	Top plugged for electrical control, use with power beyond

*Port types*

Code		1	2	3	4	5	6	7	8	9	X
Threads		SAE - ORB			BSP - Parallel			Metric - ISO 6149			Special porting, specify
		#8 3/4 -16UNF	#10 7/8 -14UNF	#12 1 1/16-12UNF	3/8 -19	1/2 -14	3/4 -14	M18x1.5	M22x1.5	M27x2	
Model CDS100	Inlet outlet		●	●		●	●		●	●	
	Section		●	●		●	●		●	●	
Model CDS60	Inlet outlet	●	●		●	●		●	●		
	Section	●	●		●	●		●	●		

● available

Note: At this time, North America only stocks SAE-Oring boss.

Outlet covers order code (example)

**S60 A 2**

**OUTLET PORTING AND PLUG OPTIONS**

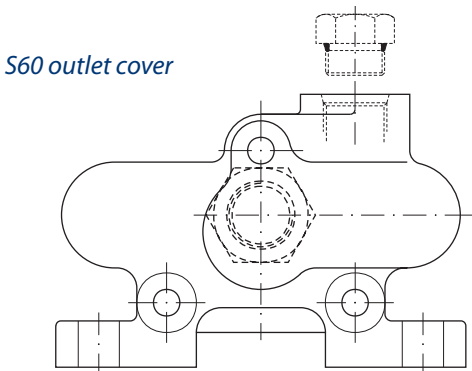
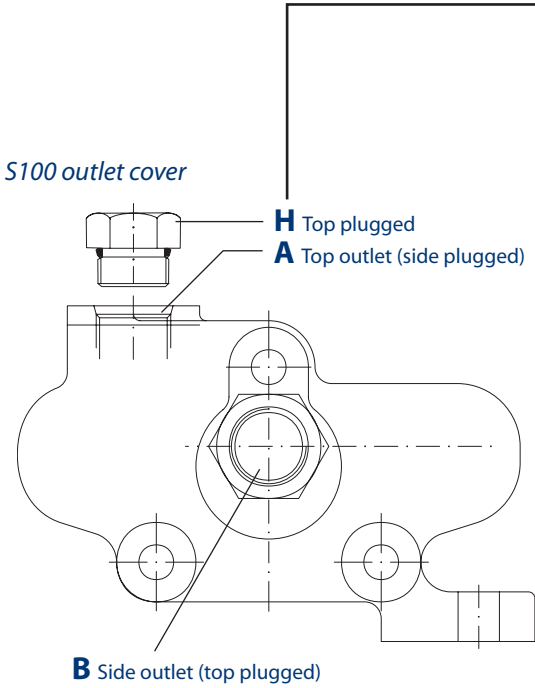

P101 799E

<b>C</b>		
<b>I</b>		
<b>D*</b>		
<b>E</b>		
<b>J</b>		
<b>F</b>		
<b>L</b>		
<b>G</b>		

\*Typically used for high pressure standby.

mm [in]

**WORK SECTION ORDER CODE**

*Model*

<b>A100</b>	CDS 100 body for supporting valves
<b>B100</b>	CDS 100 normal body (no valves)
<b>A60</b>	CDS 60 body for supporting valves
<b>B60</b>	CDS 60 normal body (no valves)

*Circuit types, page 42*

<b>1</b>	Parallel (no priority)
<b>2</b>	Tandem (priority)
<b>3</b>	Series (no priority)

*Spool types, page 43 (also see Spool compatibility, next page)*

<b>A</b>	4-way, closed center
<b>B</b>	4-way, open center
<b>C</b>	4-way, closed center, port A plugged
<b>D</b>	4-way, closed center, port B plugged
<b>E</b>	3-way, closed center, port A plugged
<b>F</b>	3-way, closed center, port B plugged
<b>J</b>	4-way, open center, port A plugged
<b>H</b>	4-way, open center, port B plugged
<b>I</b>	Float-spool in (use centering option J)
<b>J</b>	Float-spool out (use centering option J)
<b>L</b>	4-way, closed center (metering spool)
<b>M</b>	4-way, open center (metering spool)
<b>N</b>	4-way, closed center, port A plugged (metering spool)
<b>P</b>	4-way, closed center, port B plugged (metering spool)
<b>Q</b>	3-way, closed center, port A plugged (metering spool)
<b>R</b>	3-way, closed center, port B plugged (metering spool)
<b>S</b>	4-way, open center, port A plugged (metering spool)
<b>T</b>	4-way, open center, port B plugged (metering spool)

*Spool actuation, pages 44–46*

<b>A</b>	No extension (spool actuation side and centering options omitted)
<b>B</b>	Female spool end
<b>C</b>	Male spool end
<b>D</b>	With support (no lever)
<b>E</b>	With lever
<b>F</b>	Pneumatic (use centering option A)
<b>G</b>	Cable with lever
<b>H</b>	Cable with joystick (use A for the adjacent body)
<b>I</b>	With mechanical joystick (use A for the adjacent body)
<b>J</b>	Electrical
<b>L</b>	Hydraulic
<b>M</b>	With mechanical joystick (use A for the adjacent body)
<b>N</b>	Enclosed lever — E (CDS 60 only)
<b>P</b>	Enclosed mechanical joystick — I (CDS 60 only)
<b>Q</b>	Enclosed mechanical joystick — M (CDS 60 only)

*Spool actuation mounting side, page 47*

<b>1</b>	Actuator mounted on A port side (or solenoid side A)
<b>2</b>	Actuator mounted on B port side (or solenoid side B)
<b>3</b>	Electrical A and B (use L centering type)

Work section order code (example)

**A100 1 A E 2 A 1 A B A100 140/40\***

See cabling and electrical options, page 47.

\* Default relief setting if not specified

**WORK SECTION ORDER CODE (continued)**

Work section order code (example)

A100	1	A	E	2	A	1	A	B	A100	140/40*
------	---	---	---	---	---	---	---	---	------	---------

*Spool centering and detents, page 48-49*

A	Spring centered
B	3 position detent
C	Spring centered, detent in A
D	Spring centered, detent in B
E	Spring centered, detent in A and B
F	Spring centered, hydraulic kickout
G	Spring centered, adjustable stroke
H	Spring centered, female extension
I	Spring centered, male extension
J	Spring centered, detent in float: use for floatation spool
L	Spring centered, use for electrical command
M	By spring offset
N	2-position detent, spool in
O	2-position detent, spool out
P	With switch, activates spool in
Q	With switch, activates spool in and out
R	With switch, activates two motors

*Port types*

Code		1	2	3	4	5	6	7	8	9	X
Threads		SAE - ORB			BSP - Parallel			Metric - ISO 6149			Special porting, specify
		#8 3/4 -16UNF	#10 7/8 -14UNF	#12 1 1/16-12UNF	3/8 -19	1/2 -14	3/4 -14	M18x1.5	M22x1.5	M27x2	
Model CDS100	Inlet outlet		●	●		●	●		●	●	
	Section		●	●		●	●		●	●	
Model CDS60	Inlet outlet	●	●		●	●		●	●		
	Section	●	●		●	●		●	●		

● available

Note: at this time, North America only stocks SAE O-ring boss.

*Auxiliary valves, page 50-51*

A	Plug
B	Direct relief with external adjustment (except electrical actuation)
C	Direct relief with internal adjustment
D	Pilot retaining
E	Flow control valve (electrical actuators mounted upside down)
F	Anti-cavitation
G	Direct relief with anti-cavitation and external adjustment (except electrical actuation)
H	Plastic plug
I	Direct relief with anti-cavitation and internal adjustment (electrical only)
J	Plug, for 3-way spools
K	Plug, for valves D and E
L	Plastic plug, for flow control valve
M	Plastic plug, for PO checks
For valves B, C, G, and I, specify pressure and flow Example: <b>B(140/40)</b> Pressure 140 bar flow 40 l/min	

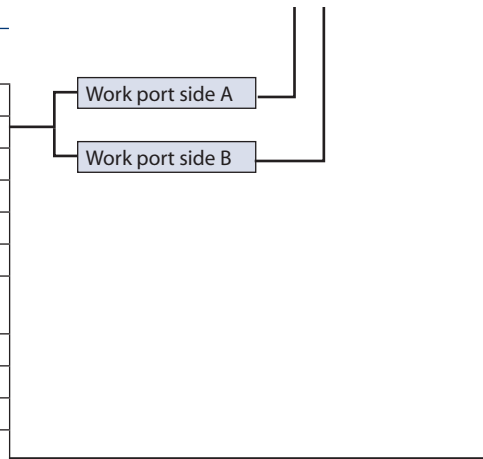

\* Default relief setting if not specified



**WORK SECTION ORDER  
 CODE (continued)**

*Spool compatibility*

Model	Spool types					
	A, C, D	B, G, H	E	F	I	J
A60/100 with pilot retaining	●	●				
A60/100 with pilot retaining and hydraulic unlock	●	●				
A60/100 with pilot retaining and electrical spool control	●	●				
A60/100 with flow control	●	●				
A60/100 with flow control and hydraulic unlock	●	●				
A60/100 with out pilot retaining	●▲	●▲	●▲	●▲	●▲	●▲
A60/100 with out pilot retaining with hydraulic unlock	●▲	●▲	▲	▲	▲	▲
A60/100 with out pilot retaining and electrical spool control	●▲	●▲	●▲	●▲	▲	▲
B60/100	●▲	●▲	●▲	●▲	●▲	●▲
B60/100 with hydraulic unlock	●▲	●▲	▲	▲	▲	▲
B60/100 with electrical spool control	●▲	●▲	●▲	●▲	▲	▲

● Parallel and tandem  
 ▲ Series

**CIRCUIT TYPES**

Work section order code (example)

**A100 1 A E 2 A 1 A B A100 140/40\***

**1 Parallel circuit (no priority)**

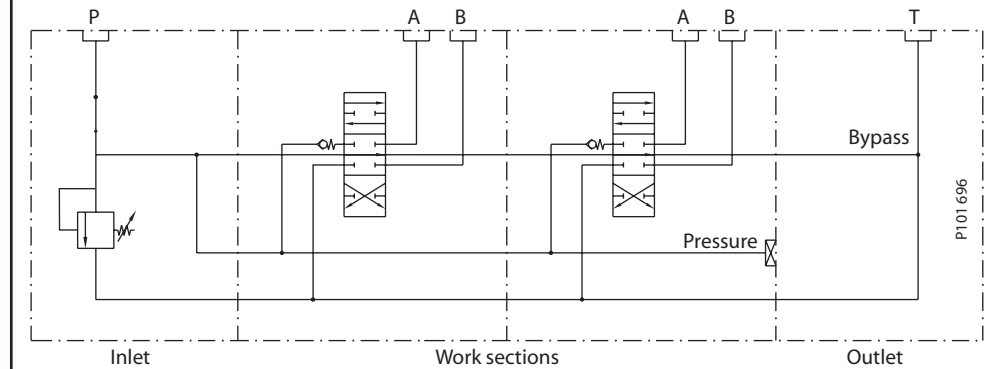

**When two or more sections operate simultaneously, flow favors the lowest pressure.**

**2 Tandem circuit (priority)**

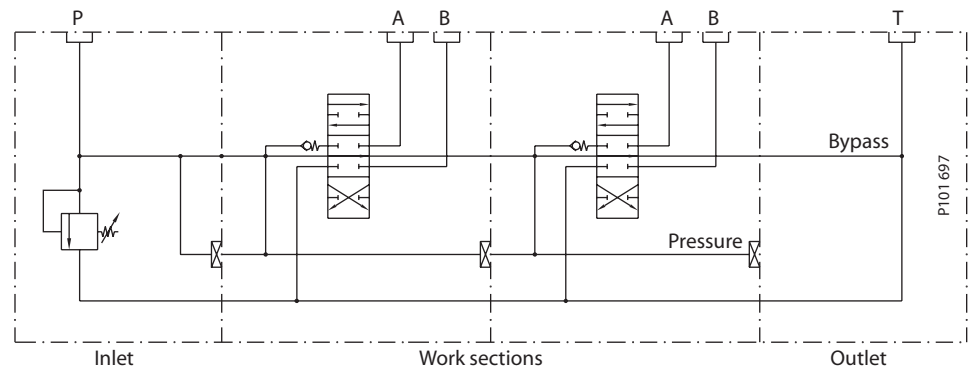

**When two or more sections operate simultaneously, only the section closest to the inlet receives flow.**

**3 Series circuit (no priority)**

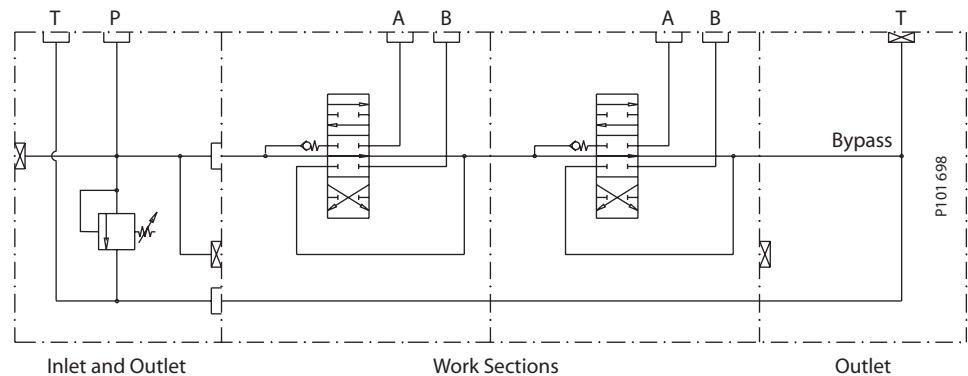

**When two or more sections operate simultaneously, the section closest to the inlet receives flow. Return flow feeds the sections downstream.**

\* Default relief setting if not specified

Work section order code (example)

**A100 1 A E 2 A 1 A B A100 140/40\***

**SPOOL TYPES**

Standard central body

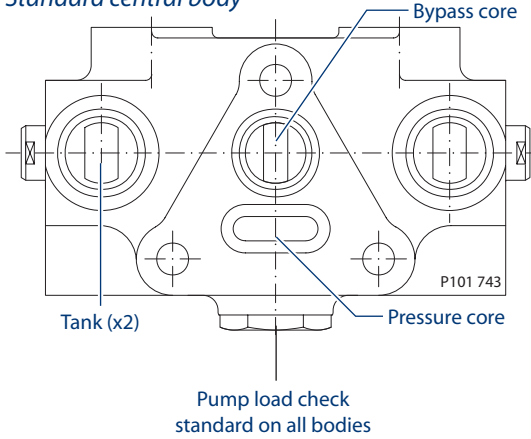

Central body for use with auxiliary valves

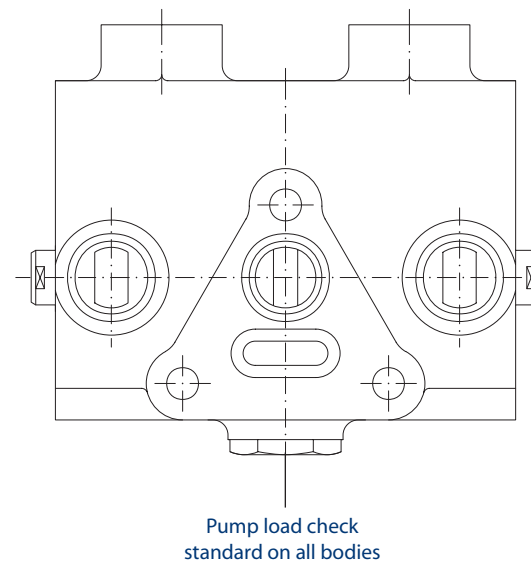

Ref.	Description	Symbol
<b>A</b>	4-way closed center	
<b>L</b>	4-way closed center metering spool	
<b>B</b>	4-way open center	
<b>M</b>	4-way open center metering spool	
<b>C</b>	4-way closed center port A plugged	
<b>N</b>	4-way closed center port A plugged metering spool	
<b>D</b>	4-way closed center port B plugged	
<b>P</b>	4-way closed center port B plugged metering spool	
<b>E</b>	3-way closed center port A plugged	
<b>Q</b>	3-way closed center port A plugged metering spool	
<b>F</b>	3-way closed center port B plugged	
<b>R</b>	3-way closed center port B plugged metering spool	
<b>G</b>	4-way open center port A plugged	
<b>S</b>	4-way open center port A plugged metering spool	
<b>H</b>	4-way open center port B plugged	
<b>T</b>	4-way open center port B plugged metering spool	
<b>I</b>	Float spool in (inner inverter)	
<b>J</b>	Float spool out (outer inverter)	

\* Default relief setting if not specified

**ACTUATION OPTIONS**

Work section order code (example)

**A100 1 A E 2 A 1 A B A100 140/40\***

**A Without spool end**

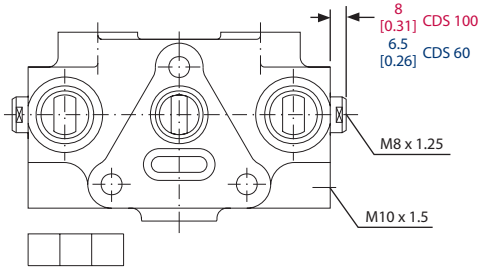

**B Female spool end (clevis)**

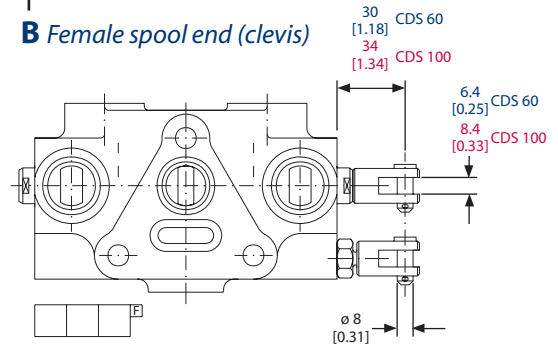

**C Male spool end (tang)**

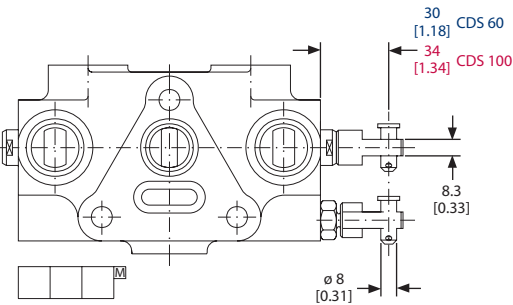

**D With support**

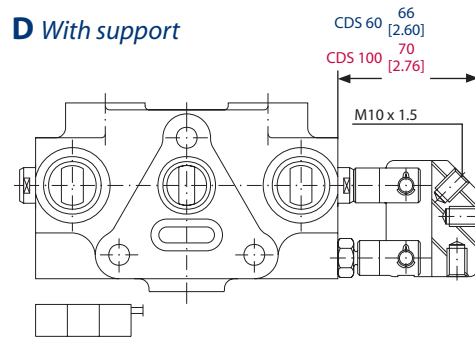

**E With lever**

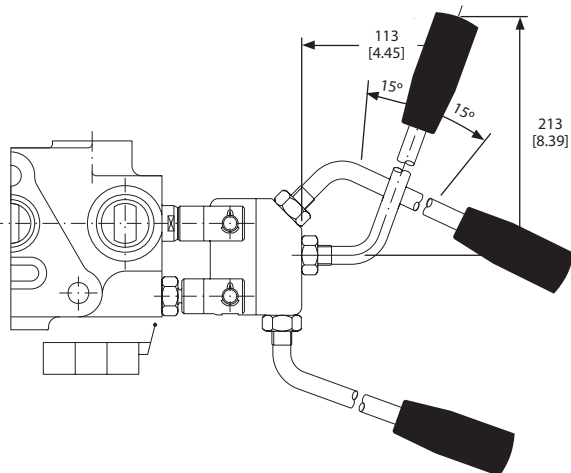

**F Pneumatic**

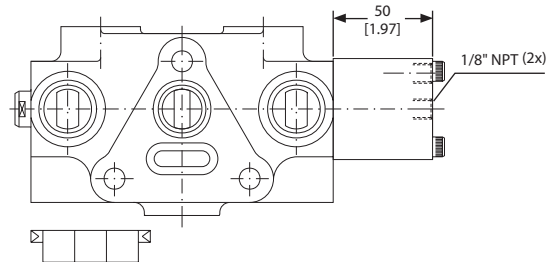

Minimum air pressure CDS 60: 5 bar [73 psi]  
 Minimum air pressure CDS 100: 8 bar [116 psi]  
 Maximum air pressure: 12 bar [174 psi]

**L Hydraulic**

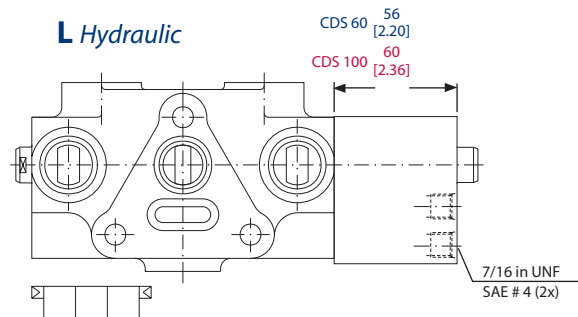

Minimum pressure CDS 60: 8 bar [116 psi]  
 Minimum pressure CDS 100: 12 bar [174 psi]  
 Maximum pressure: 100 bar [1450 psi]

mm [in]

\* Default relief setting if not specified

Work section order code (example)

A100	1	A	E	2	A	1	A	B	A100	140/40*
------	---	---	---	---	---	---	---	---	------	---------

**ACTUATION OPTIONS (continued)**

**G Cable with lever\*\***

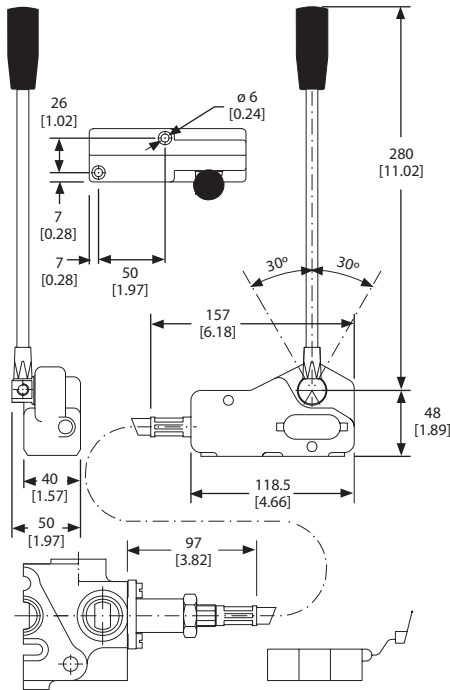

**H Cable with joystick\*\***

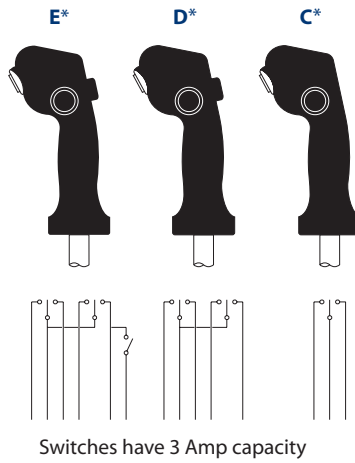

**N, P, Q Consult factory for drawings**

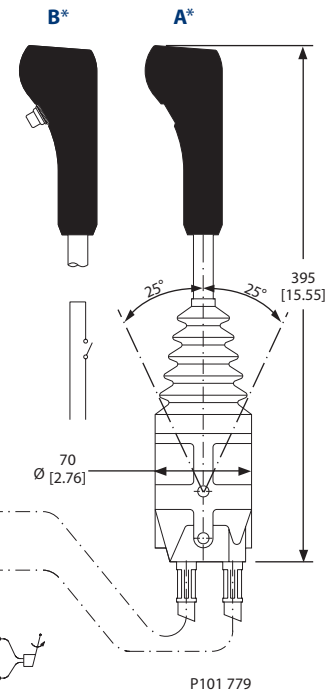

**I/M Mechanical joystick**

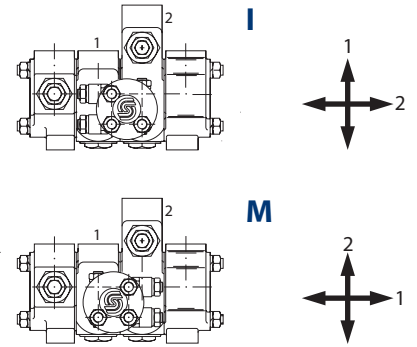
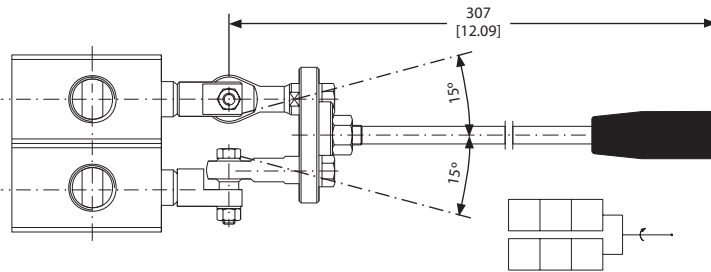

**J Electrical\*\***

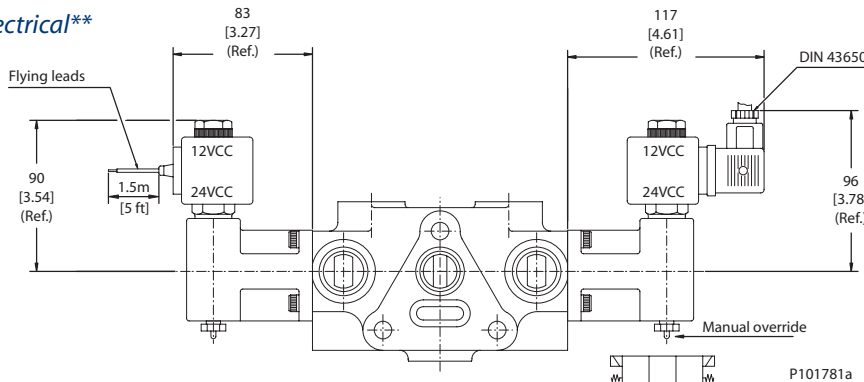

\*\*See cabling and electrical options, page 47.

Standard sections cannot be converted to electrical due to internal pilot.

Minimum pilot pressure to actuate: 35 bar [500 psi]

mm [in]

\* Default relief setting if not specified

**ACTUATION OPTIONS (continued)**

Work section order code (example)

A100	1	A	E	2	A	1	A	B	A100	140/40*
------	---	---	---	---	---	---	---	---	------	---------

**N** Enclosed lever

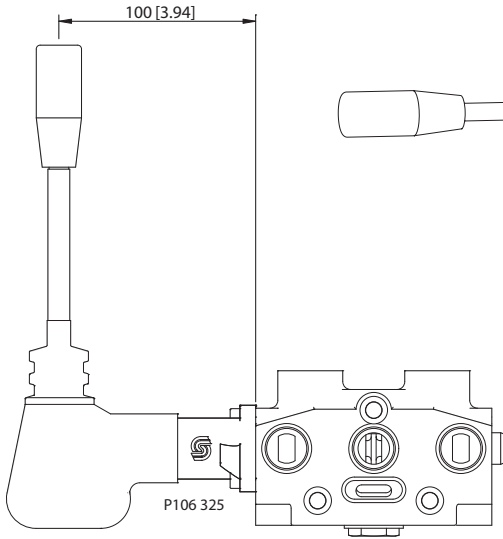

**P/Q** Enclosed mechanical joystick

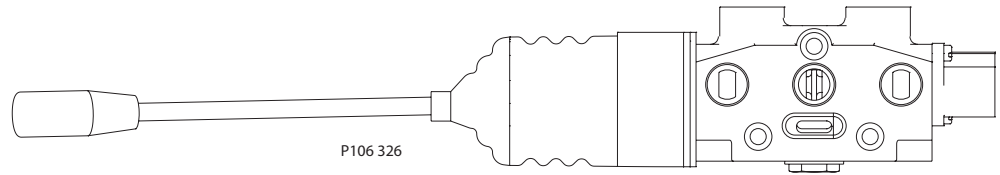

For dimensions, see *I/M Mechanical joystick option*, previous page.

**CABLING AND ELECTRICAL  
 OPTIONS FOR ACTUATOR  
 TYPES G, H, AND J**

Work section order code (example)  
**A100 1 A E 2 A 1 A B A100 140/40\***

**G: Flexible cable and lock options for spool control lever**

	A	B	C
<b>Lever lock options</b>	Without lock	Lock in A and/or B	Lock in central position
<b>Standard cables</b>	100 - 125 - 150 - 175 - 200 - 250 - 275 - 300 - 325 - 350 - 400 - 450 - 500 cm (other: consult)		
<b>Example: how to order</b>	A60 - 1AG2A1 - AB - <b>A100</b> - 140/40 (lever without lock, 100 cm cable)		

**H: Flexible cable and handle options controls for joystick**

	A	B	C	D	E
<b>Joystick handle options</b>	Without switches	On-Off switch	On-Off-On switch	Two On-Off-On switches	Two On-Off-On switches and one On-Off switch
<b>Standard cables</b>	100 - 125 - 150 - 175 - 200 - 250 - 275 - 300 - 325 - 350 - 400 - 450 - 500 cm (other: consult)				
<b>Example: how to order</b>	A60 - 1AH2A1 - AB - <b>A100</b> - 140/40 (handle without switches, 100 cm cable)				

**J: Electrical spool voltage and termination options**

<b>Voltage</b>	A	B	E	F
	12 VDC - lead wires	24 VDC - lead wires	12 VDC - DIN 43650 conn.	24 VDC - DIN 43650 conn.
<b>Example: how to order</b>	A60 - 1AJ3L1 - AC - <b>A</b> 140/40 (12 VDC coil with lead wires)			

**Force requirements**

kgf [lbf]	CDS 60	CDS 100
<b>Push/pull min.</b>	2 [4.4]	3.5 [7.7]
<b>Max. tension</b>	250 [551]	250 [551]

**Electrical specifications**

Voltage	Amperage (A)	Resistance (Ω)
12 VDC	1.75	6.85
24 VDC	0.88	27
Power: 21 W		

**ACTUATION MOUNTING  
 SIDE**

**1 Actuation on A port side (RH inlet shown)**

**2 Actuation on B port side (LH inlet shown)**

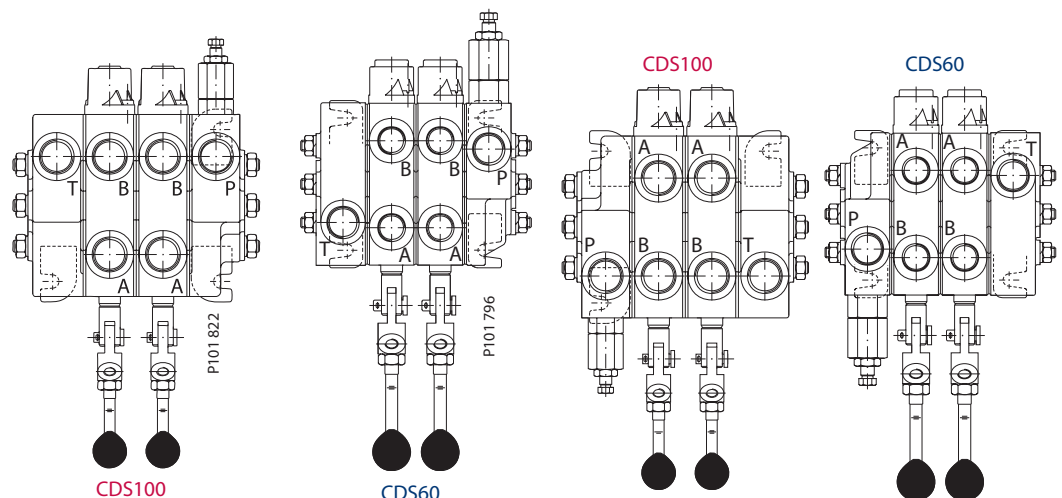

\* Default relief setting if not specified

Work section order code (example)

**SPOOL CENTERING AND DETENT OPTIONS**

**A100 1 A E 2 A 1 A B A100 140/40\***

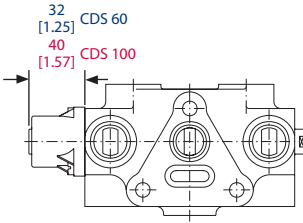
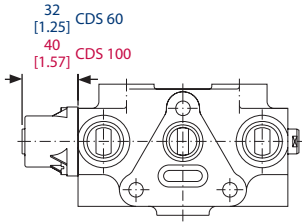
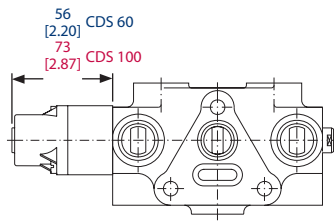
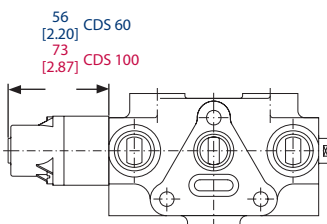
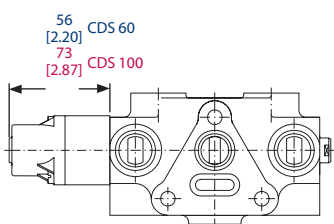
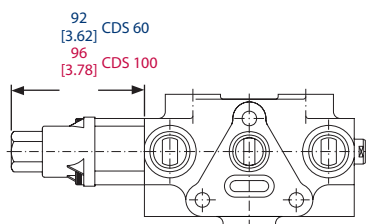
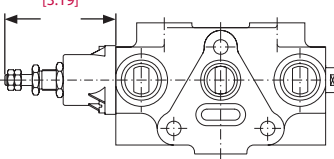
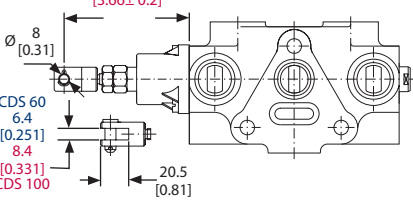
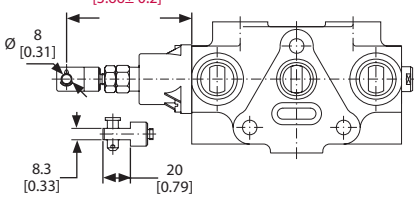
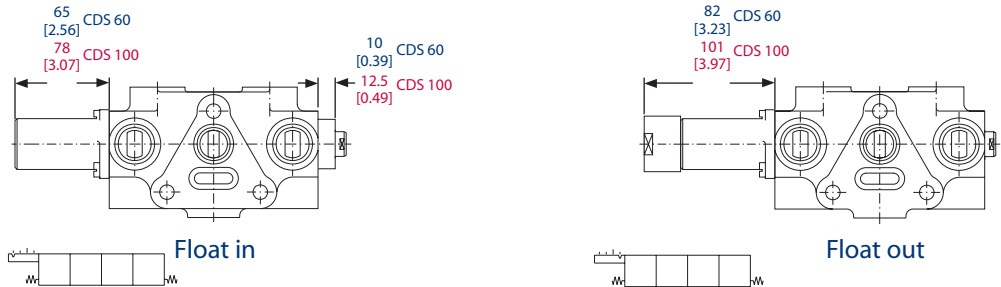
<p><b>A Spring centered</b></p>  <p>Spring force CDS 60: 145-155 N [32-35 lbf] CDS 100: 240-245 N [54-55 lbf]</p>	<p><b>B 3 position detent</b></p> 	<p><b>C Spring center in, detent out</b></p> 
<p><b>D Spring center out, detent in</b></p> 	<p><b>E Spring centered, detent in A and B</b></p> 	<p><b>F Spring centered, hydraulic unlock</b></p>  <p>Note: Unlock body section required for use with hydraulic unlock kit.</p>
<p><b>G Spring centered, adjustable stroke</b></p>  <p>Note: Adjustable in both directions.</p>	<p><b>H Spring centered, female extension</b></p> 	<p><b>I Spring centered, male extension</b></p> 
<p><b>J Spring centered, floatation spool</b></p> <p>Note: Float body section required</p>  <p>Float in</p> <p>Float out</p>		

mm [in]



Work section order code (example)

**A100 1 A E 2 A 1 A B A100 140/40\***

**SPOOL CENTERING AND DETENT OPTIONS (continued)**

<p><b>M</b> Spring offset</p>	<p><b>N</b> Two-position detent: neutral and spool in</p>	<p><b>O</b> Two-position detent: neutral and spool out</p>
<p><b>P</b> Spring centered with switch: activates on spool in</p>	<p><b>Q</b> Spring centered with switch: activates on spool in and out</p>	<p><b>R</b> Spring centered with switch: activates two motors</p>

P106 330E

mm [in]

\* Default relief setting if not specified

**AUXILIARY VALVES**

Work section order code (example)

**A100 1 A E 2 A 1 A B A100 140/40\***

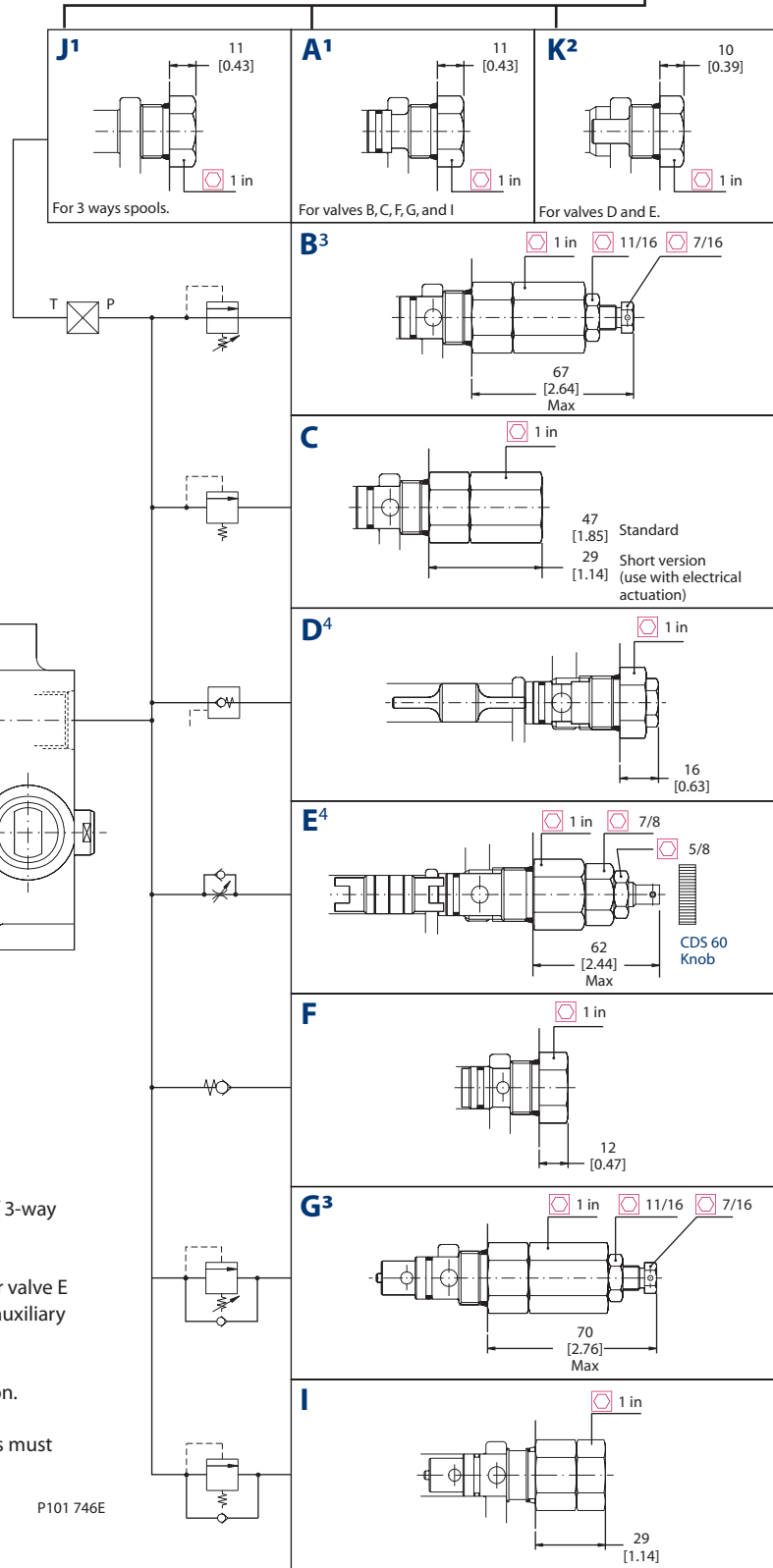

Central body for use with auxiliary valves

<sup>1</sup> Order code H for plastic plug in auxiliary port of 3-way spool and body for valves B, C, F, G, and I.

<sup>2</sup> Order code L for plastic plug in auxiliary port for valve E (flow control L). Order code M for plastic plug in auxiliary port for valve D (pilot retaining).

<sup>3</sup> Don't use valves B and G with electrical actuation.

<sup>4</sup> When using options D and E, electrical actuators must be mounted upside down.

P101 746E

mm [in]

\* Default relief setting if not specified



**DIMENSIONS CDS 60**

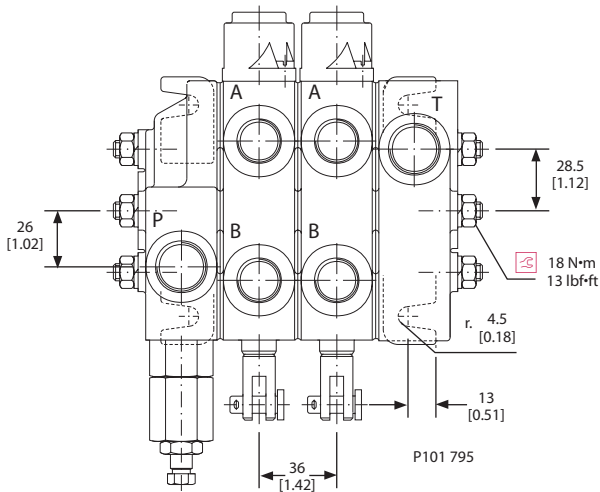
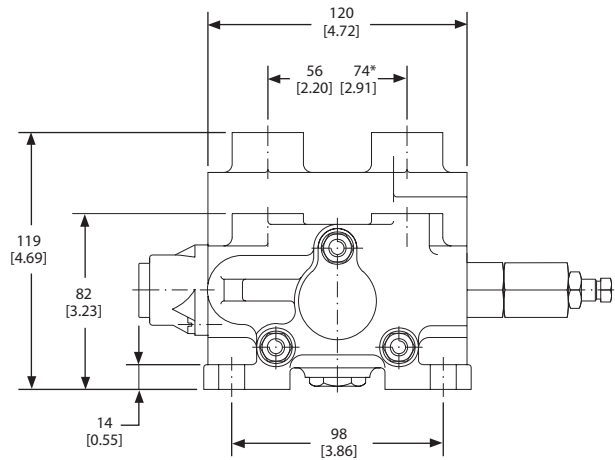
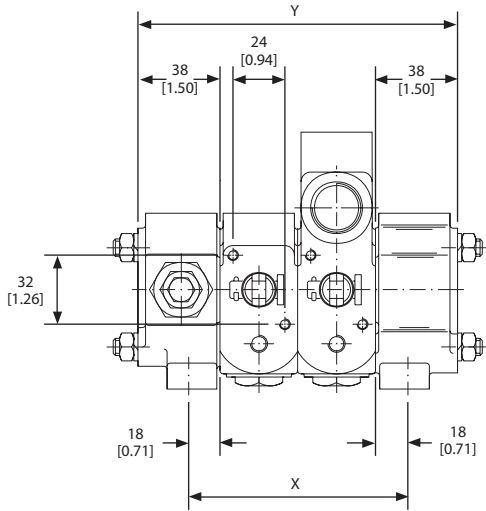

*Reference dimensions*

Number of sections	X		Y	
1	72	[2.83]	112	[4.41]
2	108	[4.25]	148	[5.83]
3	144	[5.67]	184	[7.42]
4	180	[7.09]	220	[8.66]
5	216	[8.50]	256	[10.08]
6	252	[9.92]	292	[11.50]
7	288	[11.34]	328	[12.91]
8	324	[12.76]	364	[14.33]
9	360	[14.17]	400	[15.75]
10	396	[15.59]	436	[17.17]
11	432	[17.01]	472	[18.58]
12	468	[18.43]	508	[20.00]

*Mounting requirements*

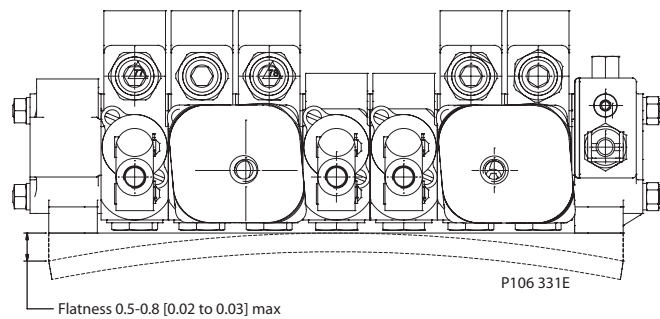
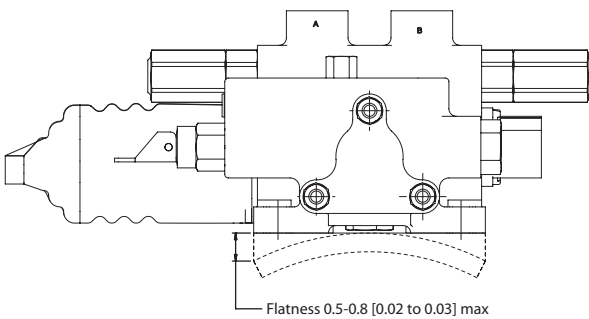

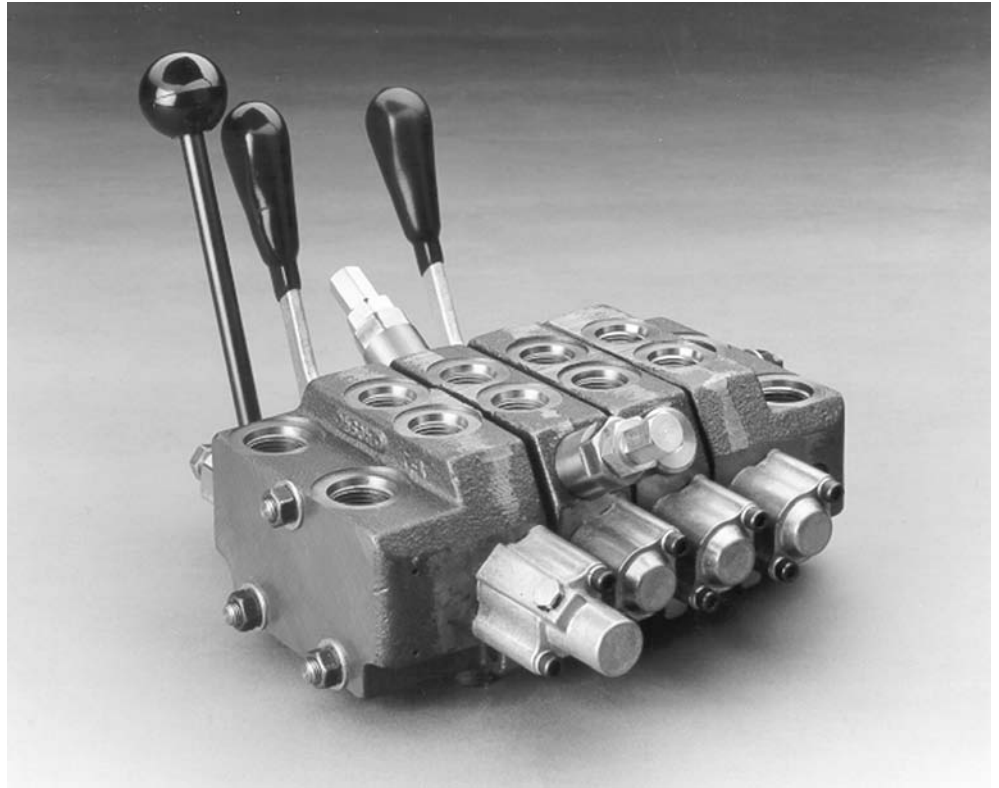
**TYPICAL APPLICATIONS**

Car transport haulers, small backhoes, utility trucks, and mini-excavators

**STANDARD FEATURES**

- All valves supplied with clevis end spools
- Power-beyond port machined and plugged (use whenever a downstream valve is required)
- Cast-iron body
- Chrome plated spools select fit to body for leakage control
- Load-check for each spool to prevent load drop before raise
- All porting options machined and plugged
- Individually boxed and labeled

**PRESSURE DROP CURVES** *Pressure vs. flow P→T*

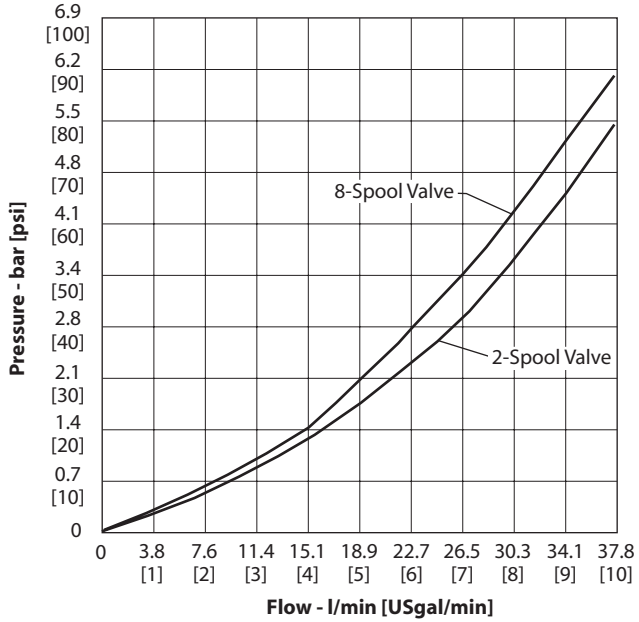

*Pressure vs. flow P→A/B*

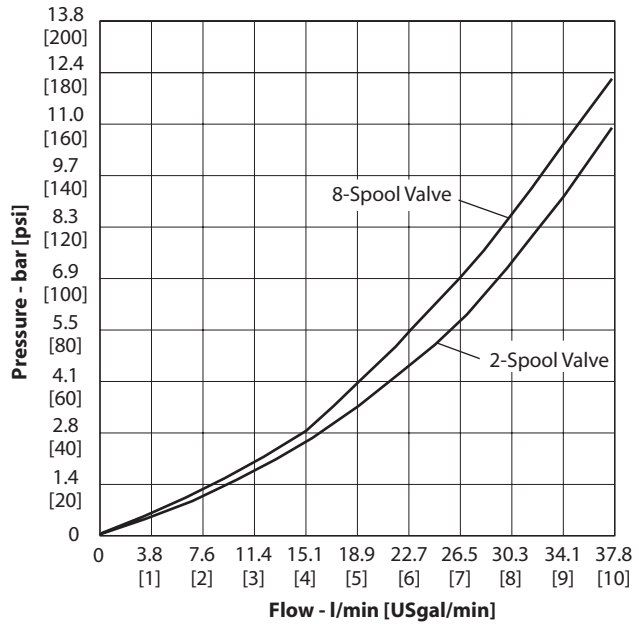

**PRESSURE DROP CURVES  
 (continued)**

*Pressure vs. flow A/B→T*

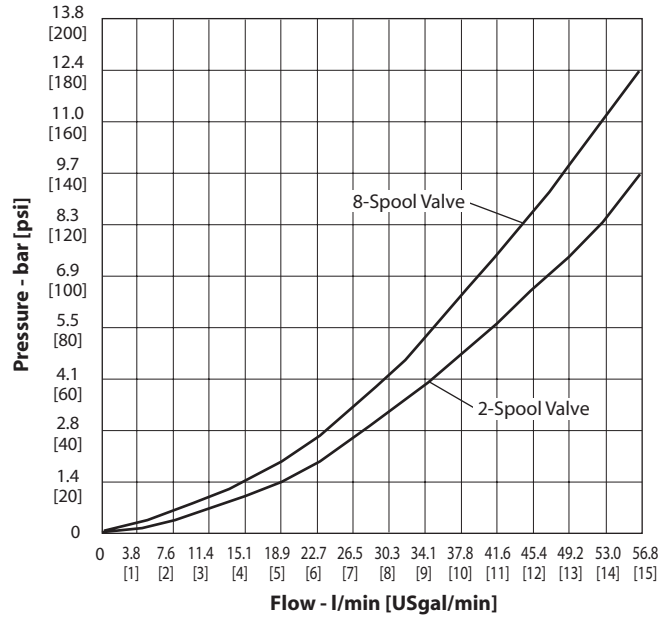

**PRESSURE RISE CURVES  
 (SYSTEM RELIEF VALVE  
 SVPR)**

*Pressure vs. flow P→T*

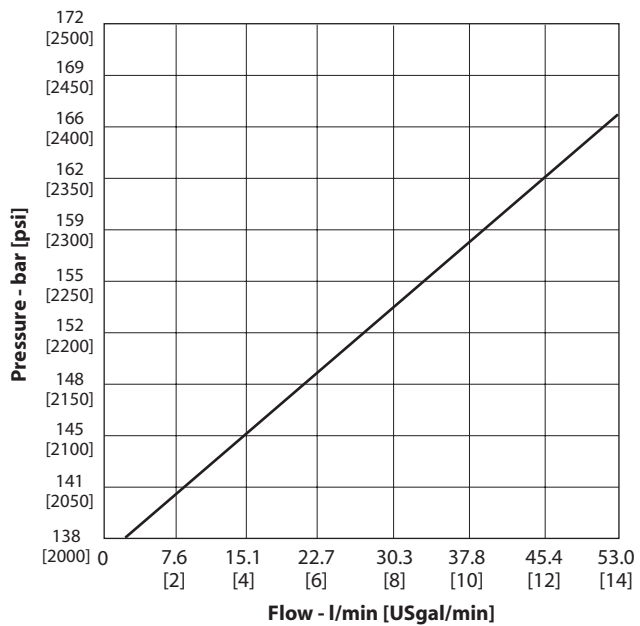

**With system relief SVPR set to 138 bar [2000 psi] at 2.8 l/min [0.75 US gal/min]**

**PRESSURE RISE CURVES  
 (WORK PORT RELIEF  
 VALVE SVLP)**

*Pressure vs. flow P→A/B*

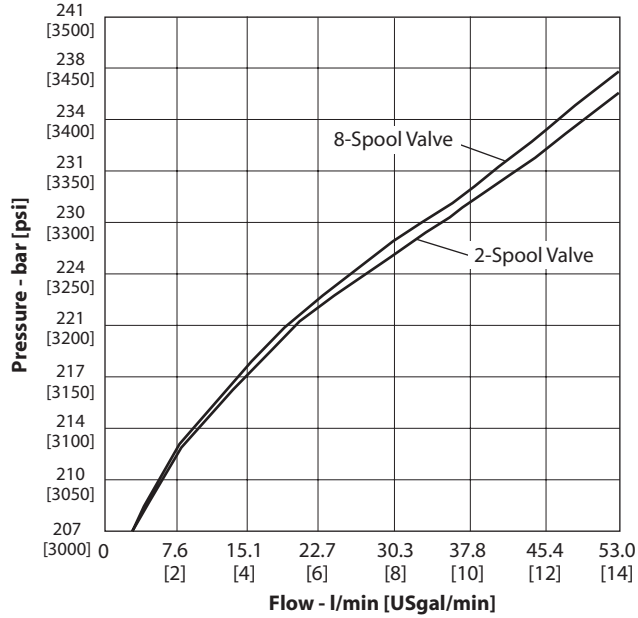

With work port relief SVLP set to 206 bar [3000 psi] at 2.8 l/min [0.75 US gal/min]

*Pressure vs. flow A/B→T*

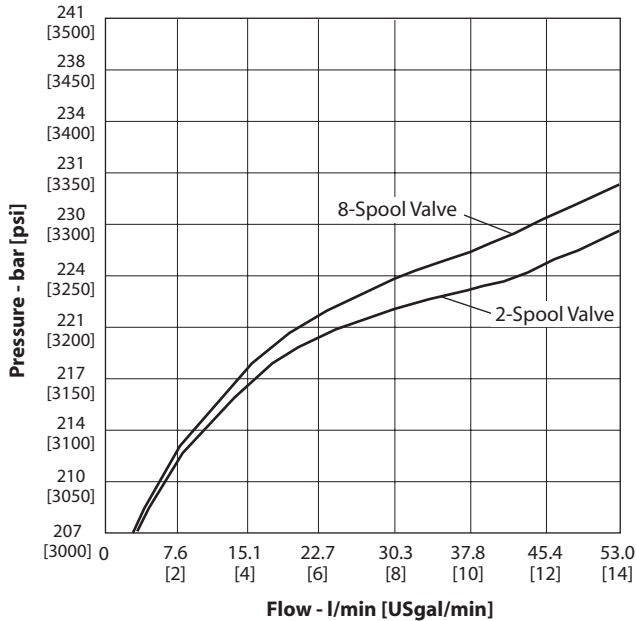

With work port relief SVLP set to 206 bar [3000 psi] at 2.8 l/min [0.75 US gal/min]



**PORTING**

<b>SVPB</b>	<b>Inlet/outlet</b>	7/8-14 SAE 10
	<b>Locations available</b>	Inlet - top Outlet - top on both sections SVSB and SVPB
<b>SVB</b>	<b>Work ports</b>	3/4-16 SAE 8, 7/8-14 SAE 10
<b>SVHC</b>	<b>Power beyond</b>	Power-beyond port machined and plugged. Remove plug and install internal plug for power-beyond feature. 7/8-14 SAE 10

**HANDLES SVM**

Code	Description
H	Standard handle with C-hook kit (156B8587)
P	Pivot-block handle kit (156B8302)

**TECHNICAL DATA**

<b>Maximum pressure</b>	205 bar	[3000 psi]
<b>Maximum tank line pressure</b>	70 bar	[1000 psi]
<b>Maximum oil flow</b>	38 l/min	[10 US gal/min]
<b>Spool travel in and out from neutral</b>	4.8 mm	[0.19 in]
<b>Maximum port leakage at 69 bar [1000 psi] 21 mm<sup>2</sup>/sec (cSt) [102 SUS]</b>	16 cm <sup>3</sup> /min	[1 in <sup>3</sup> /min]
<b>Maximum lift check leakage at 70 bar [1000 psi] 21 mm<sup>2</sup>/sec (cSt) [102 SUS]</b>	82 cm <sup>3</sup> /min	[5 in <sup>3</sup> /min]
<b>Minimum oil temperature</b>	-29 °C	[-20° F]
<b>Maximum oil temperature</b>	82° C	[180° F]
<b>Ambient temperature range</b>	-29° to 60° C	[-20° to 140° F]
<b>Minimum viscosity</b>	6 mm <sup>2</sup> /sec (cSt)	[45 SUS]
<b>Maximum viscosity</b>	440 mm <sup>2</sup> /sec (cSt)	[2000 SUS]
<b>Fluid cleanliness per ISO 4406</b>	19/16	
<b>Standard spool forces: Dry</b>	205 N	[46 lbf]

**OPTIONS**

*Spool types*

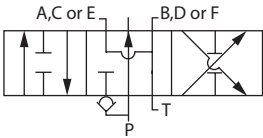
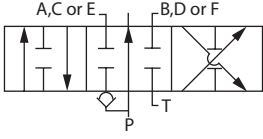
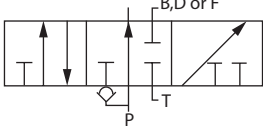
Code	Symbol	Description
O		4-way, 3-position Closed center motor Work-ports open to tank in neutral position
T		4-way, 4-position Open center Work-ports blocked to tank in neutral position
V		3-way, 3-position Open center Work-ports blocked to tank in neutral - B port

**OPTIONS  
 (continued)**

*Spool actions SVMB*

Code	Description
D	3-position detent (156B8399)
S	Spring centered (156B8315)

*Relief valve SVLP*

Code	Description
3	Pilot operated relief valve <ul style="list-style-type: none"> <li>• 0.4 bar/l [20 psi/gal] rise</li> <li>• No restrictions on setting up to 207 bar [3000 psi]</li> <li>• Standard setting 138 bar [2000 psi] crack pressure at 2.9 l/min [0.75 US gal/min]</li> </ul>

*Work port relief valve SVLP*

<b>156B8311</b> 34–172 bar [500–2500 psi]	Std. Setting - 83 bar [1200 psi] crack pressure at 2.9 l/min [0.75 US gal/min]
<b>156B8312</b> 172–206 bar [2500–3000 psi]	Std. Setting - 172 bar [2500 psi] crack pressure at 2.9 l/min [0.75 US gal/min]

**TYPICAL CIRCUIT**

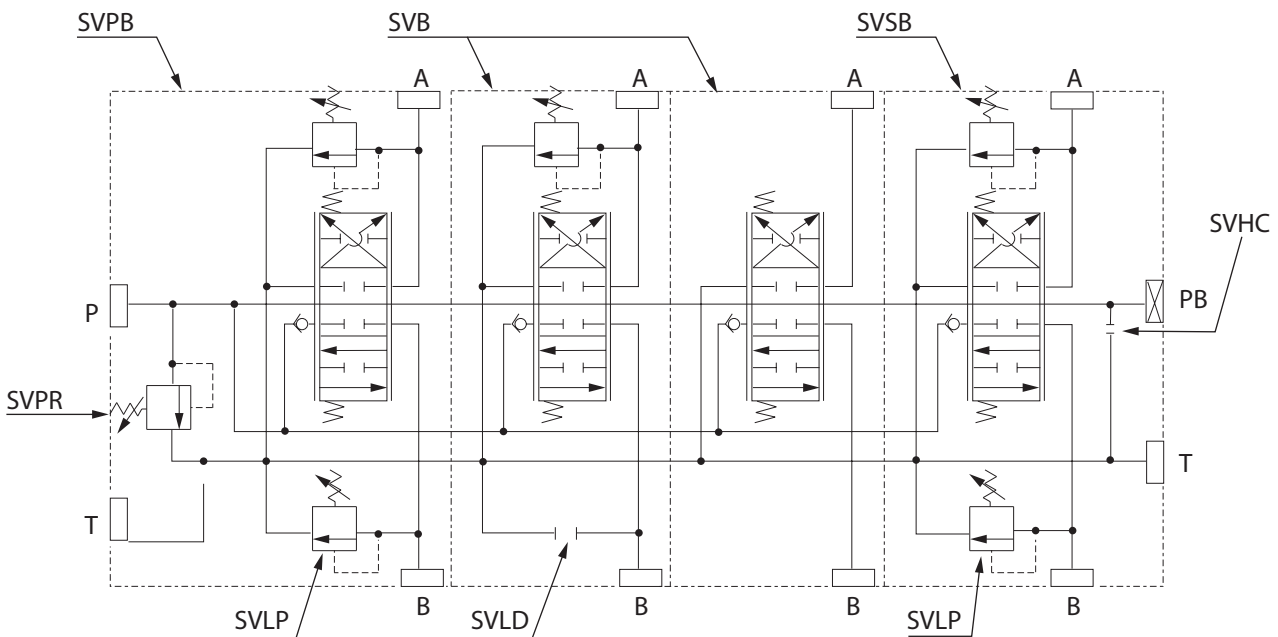

**DIMENSIONS**

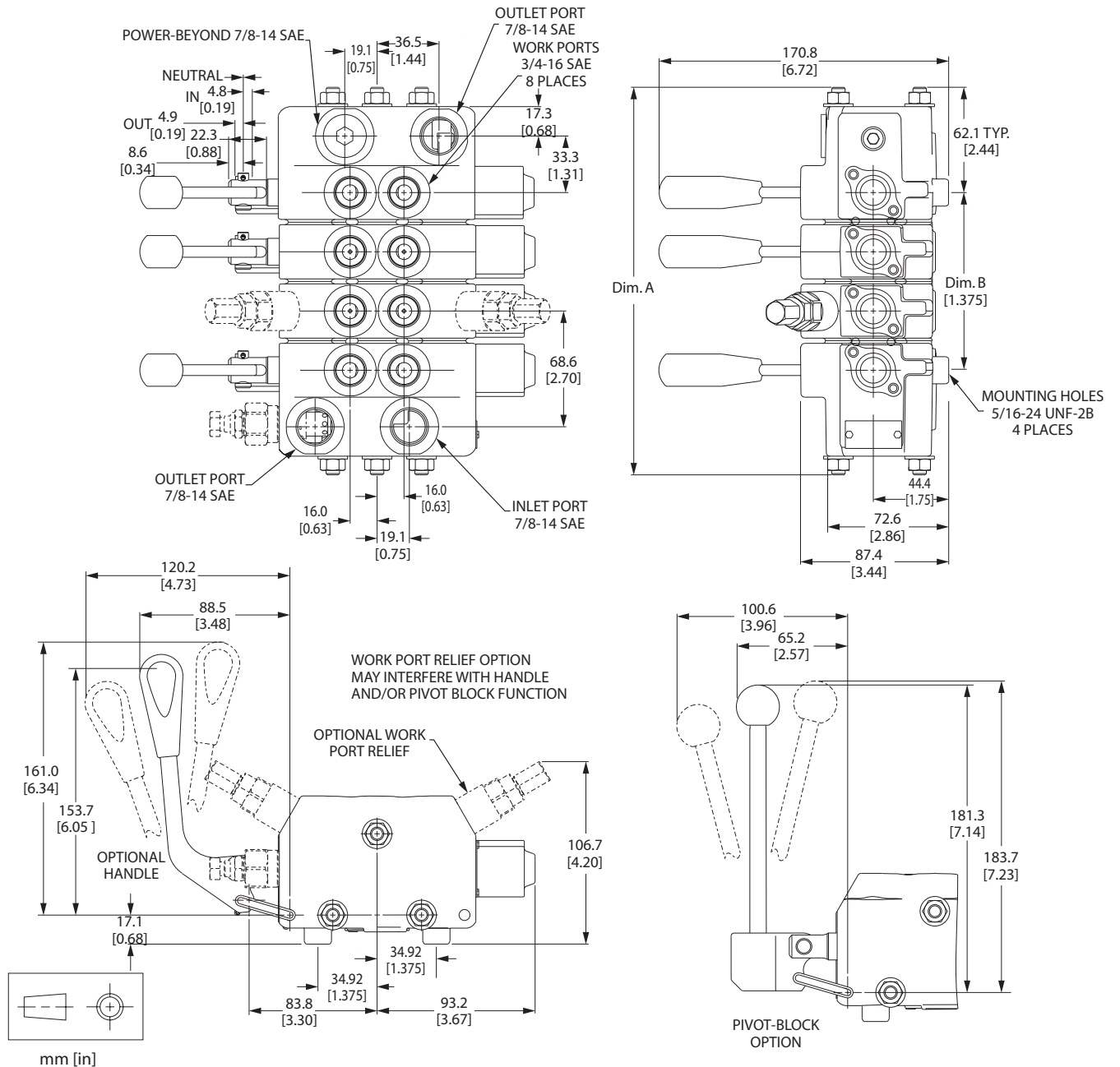

Spools	Sections	Dimension A	Dimension B	Spools	Sections	Dimension A	Dimension B
2	I & O	158.8 [6.25"]	1.375	6	I & O & 4B	298.5 [11.75"]	6.875
3	I & O & B	193.5 [7.62"]	2.750	7	I & O & 5B	333.5 [13.13"]	8.250
4	I & O & 2B	228.6 [9.00"]	4.125	8	I & O & 6B	368.3 [14.50"]	9.625
5	I & O & 3B	263.7 [10.38"]	5.50				

#### EXPLODED VIEW

Part numbers on this page are for service only.

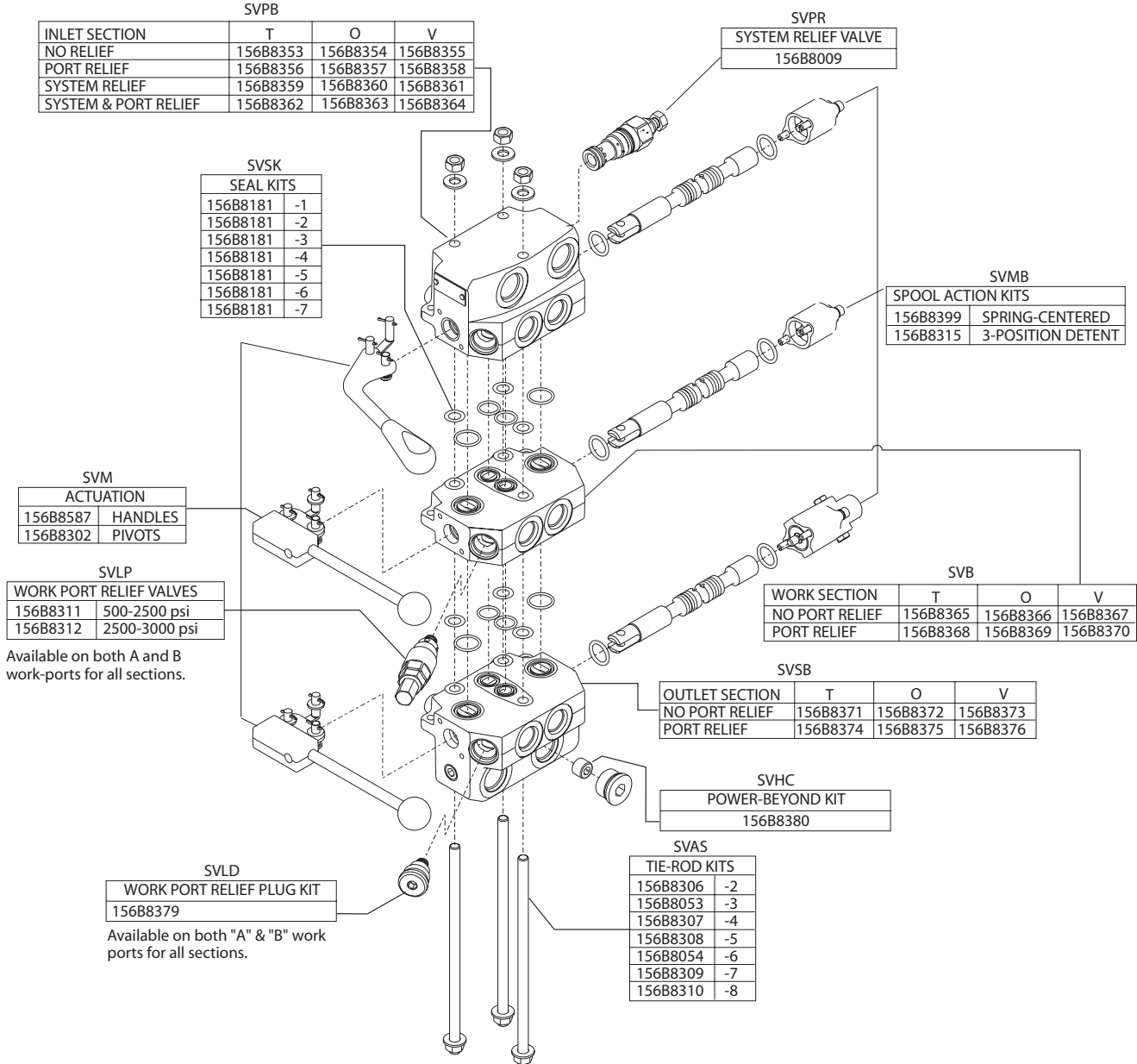



Directional Control Valves  
 Technical Information  
 Appendix 1 – Order forms

**SPOOL VALVE ORDER FORM**

Tandem Models: 1500, 1530, 1612, 1617, 1618, 1025, 1225, and 1421 (1618- PO Check Capable)

Parallel Models: 1627, 1637, 1638 And 1681. (1638- PO Check Capable)

Series Models: 1622, 1632, and 1635 (Contact Sauer-Danfoss)

Ordering code:     -   -   -   -

1                      2    3                      2    3                      2    3                      4    4A    5    6    7    8

Qty. \_\_\_\_\_

**1. Model (4 digits)** .....

#1    #2    #3

**2. Spool type T, X, O, V, C, R, F** (Standard spools are clevis type) .....

(Confirm spool type using table 1, next page)

#1    #2    #3

**3. Spool action** .....

(\* Option not available with **M** handle kit)

- A** Spring center detent float
- C\*** 2- position detent
- D** 3 -position detent
- F\*** Friction pad
- K** Spring center, detent in & out
- L** Spring center, detent out
- M** Motor start switch in & out
- N** Spring center, detent in
- O** Spring offset
- S** Spring center

**4. Relief valve** .....

- 1. No relief required
- 2. Direct acting ball and spring (use for 30 l/min [8 US gal/min] and below)  
Standard setting is 83 bar [1200 psi] crack pressure at 2.85 l/min [0.75 US gal/min]
- 3. Pilot operated relief valve (use for 30 l/min [8 US gal/min] and above)  
Standard Setting is 138 bar [2000 psi] crack pressure at 2.85 l/min [0.75 US gal/min]  
(See porting, table 2 next page, to ensure option availability)

**4A.** .....

- 0** Standard Setting
- 1** Special Setting  
(Specify Special Setting Required) \_\_\_\_\_ Pressure at \_\_\_\_\_ US gal/min

**5. Porting sizes 4, 5, or 6** .....

(See table 2, next page, for standard port sizes offered for each model)

**6. Handles** .....

- C** C-hook link only
- F** Joystick available for 1627 (used with tang spools only)
- H** Standard handle with connecting hardware
- M** Cam (offered for 1421 only)
- N** No handle required (1530 has no handle option)
- P** Pivot block handle (offers three possible angles in one part)

**7. Packing** .....

- S** Individually boxed
- B** Bulked packed

**8. Power beyond sleeve** Isolates inlet to tank neutral flow, directs flow to desired function down stream of valve  
 (Bushing required)

**Bushing port size**

- 0** None
- 1** 9/16 in
- 2** 3/4 in
- 3** 7/8 in

Prepared by \_\_\_\_\_ Date \_\_\_\_\_

Table 1 – spool type

	<p><b>T</b>        4-way, 3-pos.        open center        work ports blocked to        tank in neutral position</p>		<p><b>X</b>        3-way, 3-pos.        open center        work port blocked to tank        in neutral - A port</p>
	<p><b>O</b>        4-way, 3-pos.        open center        work ports open to tank        in neutral position</p>		<p><b>V</b>        3-way, 3-pos.        open center        work port blocked to tank        in neutral - B port</p>
	<p><b>C</b>        4-way, 3-pos        closed center        work ports blocked to tank        in neutral position</p>		<p><b>R</b>        4-way, 3-pos        closed center        work ports open to tank        in neutral position</p>
		<p><b>F</b>        4-way, 3-pos        open center        work ports blocked to tank in neutral        open to tank in fourth position float</p>	

Table 2 – porting

Model	4 - No Relief Valve	5 - Ball and Spring Relief Valve	6 - Pilot Operated Relief Valve
1617, 1627, 1637	End In and Out - top in and Out - side In All 3/4-16 SAE Work ports 9/16-18 SAE Power Beyond cavity machined and plugged with a solid plug at factory.	Same as 4, except with ball and spring relief valve installed at factory, set at 83 bar [1200 psi].	Same as 4 except with pilot operated relief cavity. (Non-standard).



Directional Control Valves  
 Technical Information  
 Appendix 1 – Order forms

**CDS60 AND CDS100 SPECIFICATION WORKSHEET**

<b>Directional Control Valves CDS60 and CDS100          Specification Order Form</b>										Control No.						
										Subsidiary/Dealer						
Customer					Application											
<b>Inlet Section</b>																
Model	Model Side	Port Size	Main relief Valves	Threads	Port Side Pressure	Port Side Flow										
<b>Paint</b>																
	None															
	Black Paint															
<b>Outlet Section</b>																
Model	Model Size	Ports Options	Threads													
<b>Work Sections</b>																
Work section	Model	Model Size	Circuit Type	Spool Types	Spool Controls	Spool Control Side	Center Type	Threads	Aux Valves "A"	Aux Valves "B"	Cable or Electrical Control Options	Cable Length Centi-meters	"A" Port Side Pressure (Bar)	"A" Port Side Flow (l/min)	"B" Port Side Pressure (Bar)	"B" Port Side Flow (l/min)
1st																
2nd																
3rd																
4th																
5th																
6th																
7th																
8th																
9th																
10th																
11th																
12th																
Number of sections =																
										Delivery:						Date:
										Price US \$:						







Directional Control Valves  
 Technical Information  
 Appendix 1 – Order forms

**1125 STACK VALVE SPECIFICATIONS**

Sauer-Danfoss: \_\_\_\_\_ Valve Number: \_\_\_\_\_

Revision: \_\_\_\_\_

Customer: \_\_\_\_\_ Application: \_\_\_\_\_

A-Port	SVPR _____ psi @ _____ US gal/min	B-Port
SVLP/D 156B _____ _____ psi @ _____ US gal/min SVM 156B _____	Inlet SVPB 156B _____ SVMB 156B _____	SVLP/D 156B _____ _____ psi @ _____ US gal/min SVM 156B _____
156 _____ _____ psi @ _____ US gal/min SVM 156B _____	1 SVB 156B _____ SVMB 156B _____	156B _____ _____ psi @ _____ US gal/min SVM 156B _____
156B _____ _____ psi @ _____ US gal/min SVM 156B _____	2 SVB 156B _____ SVMB 156B _____	156B _____ _____ psi @ _____ US gal/min SVM 156B _____
156B _____ _____ psi @ _____ US gal/min SVM 156B _____	3 SVB 156B _____ SVMB 156B _____	156B _____ _____ psi @ _____ US gal/min SVM 156B _____
156B _____ _____ psi @ _____ US gal/min SVM 156B _____	4 SVB 156B _____ SVMB 156B _____	156B _____ _____ psi @ _____ US gal/min SVM 156B _____
156B _____ _____ psi @ _____ US gal/min SVM 156B _____	5 SVB 156B _____ SVMB 156B _____	156B _____ _____ psi @ _____ US gal/min SVM 156B _____
156B _____ _____ psi @ _____ US gal/min SVM 156B _____	6 SVB 156B _____ SVMB 156B _____	156B _____ _____ psi @ _____ US gal/min SVM 156B _____
156B _____ _____ psi @ _____ US gal/min SVM 156B _____	Outlet SVB 156B _____ SVHC SVMB 156B _____ 156B _____	156B _____ _____ psi @ _____ US gal/min SVM 156B _____
	SVAS: 156B _____	
	SVSK: 156B _____	

Filled in by: \_\_\_\_\_

Date: \_\_\_\_\_

**1125 ORDER FORM  
INSTRUCTIONS**

An order form for Sauer-Danfoss SV 1125 hydraulic valve is shown on the next page. Photocopy this form and use it for ordering.

The order form is divided into fields.

Each module has its own field:

- 0: Combination pump and spool module, SVPB
- 1-6: Basic spool module, SVB
  - a: Mechanical actuation SVM
  - b: Spool action types, SVMB
  - c: Shock valve SVLP
- 7: Combination tank and spool module, SVAS

SVSB

- 9: Assembly kit SVAS

*Reordering*

The space at the top right-hand corner of the form is for Sauer-Danfoss to fill in. The code number for the whole of the 1125 group is entered here.

In the event of a repeat order all you have to do is enter the number Sauer-Danfoss has given on the initial confirmation of order.

Please state:

- Code number of all modules required
- Required setting (p) SVPR

Note:

If the 1125 is to be used with phosphate ester this must be stated on the order form.





## OUR PRODUCTS

Hydrostatic transmissions  
Hydraulic power steering  
Electric power steering  
Electrohydraulic power steering  
Closed and open circuit axial piston pumps and motors  
Gear pumps and motors  
Bent axis motors  
Orbital motors  
Transit mixer drives  
Planetary compact gears  
Proportional valves  
Directional spool valves  
Cartridge valves  
Hydraulic integrated circuits  
Hydrostatic transaxles  
Integrated systems  
Fan drive systems  
Electrohydraulics  
Microcontrollers and software  
Electric motors and inverters  
Joysticks and control handles  
Displays  
Sensors

## Sauer-Danfoss Mobile Power and Control Systems – Market Leaders Worldwide

Sauer-Danfoss is a comprehensive supplier providing complete systems to the global mobile market.

Sauer-Danfoss serves markets such as agriculture, construction, road building, material handling, municipal, forestry, turf care, and many others.

We offer our customers optimum solutions for their needs and develop new products and systems in close cooperation and partnership with them.

Sauer-Danfoss specializes in integrating a full range of system components to provide vehicle designers with the most advanced total system design.

Sauer-Danfoss provides comprehensive worldwide service for its products through an extensive network of Global Service Partners strategically located in all parts of the world.

Local address:

Sauer-Danfoss (US) Company  
2800 East 13th Street  
Ames, IA 50010, USA  
Phone: +1 515 239-6000  
Fax: +1 515 239-6618

Sauer-Danfoss ApS  
DK-6430 Nordborg, Denmark  
Phone: +45 7488 4444  
Fax: +45 7488 4400

Sauer-Danfoss GmbH & Co. OHG  
Postfach 2460, D-24531 Neumünster  
Krokamp 35, D-24539 Neumünster, Germany  
Phone: +49 4321 871-0  
Fax: +49 4321 871 122

Sauer-Danfoss-Daikin LTD  
Sannomiya Grand Bldg. 8F  
2-2-21 Isogami-dori, Chuo-ku  
Kobe, Hyogo 651-0086, Japan  
Phone: +81 78 231 5001  
Fax: +81 78 231 5004