



P300100.TIF

A WIDE RANGE OF ORBITAL MOTORS

Sauer-Danfoss is a world leader in the production of low speed high torque orbital motors offering more than 1600 different orbital motors, categorized in types, variants and sizes (incl. different shaft versions).

The motors vary in size (rated displacement) from 8 cm³ [0.50 in³] to 800 cm³ [48.9 in³] per revolution.

Speeds range up to approx. 2500 min⁻¹ [rpm] for the smallest type and up to approx 600 min⁻¹ [rpm] for the largest type.

Maximum operating torques vary from 13 Nm [115 lbf·in] to 2700 Nm [24.000 lbf·in] (peak) and maximum outputs are from 2.0 kW [2.7 hp] to 70 kW [95 hp].

Characteristic features:

- Smooth running over the entire speed range
- Constant operating torque over a wide speed range
- High starting torque
- High return pressure without the use of drain line (High pressure shaft seal)
- High efficiency
- Long life under extreme operating conditions
- Robust and compact design
- High radial and axial bearing capacity
- For applications in both open and closed loop hydraulic systems
- Suitable for a wide variety of hydraulics fluids

© 2001 Sauer-Danfoss

Sauer-Danfoss can accept no responsibility for possible errors in catalogues, brochures and other printed material. Sauer-Danfoss reserves the right to alter its products without prior notice. This also applies to products already ordered provided that such alterations can be made without subsequent changes being necessary in specifications already agreed. All trademarks in this material are properties of the respective companies. Sauer-Danfoss and the Sauer-Danfoss logotype are trademarks of the Sauer-Danfoss Group. All rights reserved.

Frontpage: P300048.tif, P300047.tif, P300047b.tif, P300020.tif, 151-1914.ai

The program is characterized by technical features appealing to a large number of applications and a part of the program is characterized by motors that can be adapted to a given application. Adaptations comprise the following variants among others:

- Motors with corrosion resistant parts
- Wheel motors with recessed mounting flange
- OMP, OMR- motors with needle bearings
- OMR motor in low leakage version
- OMR motors in a super low leakage version
- Short motors without bearings
- Ultra short motors
- Motors with integrated positive holding brake
- Motors with integrated negative holding brake
- Motors with integrated flushing valve
- Motors with speed sensor
- Motors with tacho connection
- All motors are available with black finish paint

Planetary gears

Sauer-Danfoss complements the motor range with a complete program of planetary gears adapted to suit. The combination of motors and gears makes it possible to obtain smooth running at fractional speeds and with torques up to 650,000 Nm [5,800,000 lbf-in].

The Sauer-Danfoss LSHT motors are used in the following application areas:

- Construction equipment
- Agricultural equipment
- Material handling & Lifting equipment
- Forestry equipment
- Lawn and turf equipment
- Special purpose
- Machine tools and stationary equipment
- Marine equipment

SURVEY OF LITERATURE WITH TECHNICAL DATA ON SAUER-DANFOSS ORBITAL MOTORS

Detailed data on all Sauer-Danfoss motors can be found in our motor catalogue, which is divided into 5 individual sub-catalogues:

- General information on Sauer-Danfoss orbital motors: function, use, selection of orbital motor, hydraulic systems, etc.
- Technical data on small motors: OML and OMM
- Technical data on medium sized motors: OMP, OMR, OMH and OMEW
- Technical data on medium sized motors: DH and DS
- Technical data on large motors: OMS, OMT and OMV
- Technical data on large motors: TMT

A general survey brochure on Sauer-Danfoss orbital motors gives a quick motor reference based on power, torque, speed and capabilities.

CONTENTS

DH and DS..... 5
 Speed, torque and output 5

DH..... 6
 Versions 6
 Code numbers 7
 Technical data 8
 Technical data (e.g. speed, torque pressure etc.) 8
 Max. permissible shaft seal pressure 9
 Pressure drop in motor, oil flow in drain line, direction of shaft rotation 9
 Permissible shaft loads 11
 Function diagrams 12
 Shaft version 17
 Port thread versions 18
 Dimensions 19

DS..... 26
 Versions 26
 Code numbers 27
 Technical data 28
 Technical data (e.g. speed, torque pressure etc.) 28
 Max. permissible shaft seal pressure 29
 Pressure drop in motor, Oil flow in drain line, Direction of shaft rotation 29
 Permissible shaft loads for DS 31
 Function diagrams 32
 Shaft version 37
 Port thread versions 38
 Dimensions 39

Hydraulic Systems 45
 Installation of the sauer-Danfoss orbital motors 45
 Starting up and running in the hydraulic system 45
 Operation 45
 Maintenance 45

Weight of motors 46

SPEED, TORQUE AND OUTPUT

The bar diagrams, see page 5, are useful for a quick selection of relevant motor size for the application. The final motor size can be determined by using the function diagram for each motor size.

- DH can be found on pages 12-16
- DS can be found on pages 32-36

The function diagrams are based on actual tests on a representative number of motors from our production. The diagrams apply to a return pressure between 5 and 10 bar [75 and 150 psi] when using mineral based hydraulic oil with a viscosity of 35 mm²/s [165 SUS] and a temperature of 50°C [120°F]. For further explanation concerning how to read and use the function diagrams, please consult the paragraph "Selection of motor size" in the technical information "General" DKMH.PK.100.G2.02 520L0232.

SPEED, TORQUE AND OUTPUT

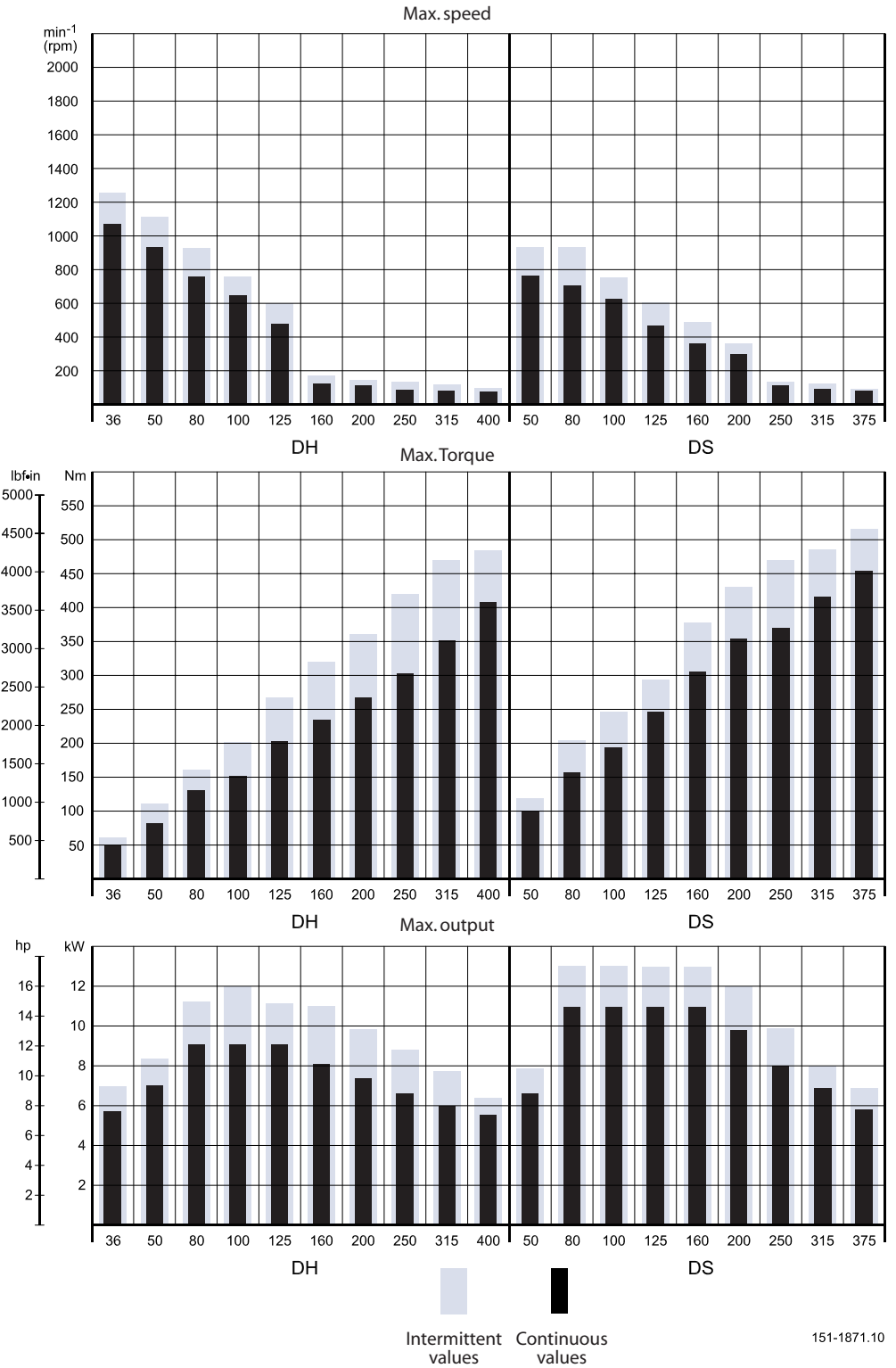

VERSIONS

Mounting flange	Shaft	Port size	European version	US version	Side port version	End port version	Flange port version	Standard shaft seal	High pressure shaft seal	Drain connection	Check valve	Specials	Main type designation
2 hole oval flange (A2-flange)	Cyl. 1 in	7/8 - 14 UNF		<input type="radio"/>	<input type="radio"/>				<input type="radio"/>	No	No		DH
		7/8 - 14 UNF		<input type="radio"/>	<input type="radio"/>				<input type="radio"/>	Yes	No		DH
		1/2 - 14 NPTF		<input type="radio"/>	<input type="radio"/>				<input type="radio"/>	No	No		DH
		1/2 - 14 NPTF		<input type="radio"/>	<input type="radio"/>				<input type="radio"/>	Yes	No		DH
		Manifold		<input type="radio"/>	<input type="radio"/>				<input type="radio"/>	No	No		DH
	1 in - 6B spl.	7/8 - 14 UNF		<input type="radio"/>	<input type="radio"/>				<input type="radio"/>	No	No		DH
		7/8 - 14 UNF		<input type="radio"/>	<input type="radio"/>				<input type="radio"/>	Yes	No		DH
		1/2 - 14 NPTF		<input type="radio"/>	<input type="radio"/>				<input type="radio"/>	No	No		DH
		Manifold		<input type="radio"/>	<input type="radio"/>				<input type="radio"/>	No	No		DH
		Manifold		<input type="radio"/>	<input type="radio"/>				<input type="radio"/>	Yes	No		DH
Square flange (C-flange)	Cyl. 1 in	7/8 - 14 UNF		<input type="radio"/>	<input type="radio"/>				<input type="radio"/>	No	No		DH
		7/8 - 14 UNF		<input type="radio"/>	<input type="radio"/>				<input type="radio"/>	Yes	No		DH
		1/2 - 14 NPTF		<input type="radio"/>	<input type="radio"/>				<input type="radio"/>	No	No		DH
		1/2 - 14 NPTF		<input type="radio"/>	<input type="radio"/>				<input type="radio"/>	Yes	No		DH
		Manifold		<input type="radio"/>	<input type="radio"/>				<input type="radio"/>	No	No		DH
	1in - 6B spl.	7/8 - 14 UNF		<input type="radio"/>	<input type="radio"/>				<input type="radio"/>	No	No		DH
		7/8 - 14 UNF		<input type="radio"/>	<input type="radio"/>				<input type="radio"/>	Yes	No		DH
		1/2 - 14 NPTF		<input type="radio"/>	<input type="radio"/>				<input type="radio"/>	No	No		DH
		Manifold		<input type="radio"/>	<input type="radio"/>				<input type="radio"/>	No	No		DH

Function diagram - see page : →

Features available (options) :
 1 in output shaft with cross hole
 Output shaft 7/8 - 13T splines
 Reverse rotation
 Drain port
 Painted

CODE NUMBERS

CODE NUMBERS	DISPLACEMENT [cm ³]										Technical data – Page	Dimensions – Page
	36	50	80	100	125	160	200	250	315	400		
151-	2000	2001	2002	2003	2004	2005	2006	2007	2008	2009	8	19
151-	3400	3401	3402	3403	3404	3405	3406	3407	3408	3409	8	20
151-	2080	2081	2082	2083	2084	2085	2086	2087	2088	2089	8	19
151-	3480	3481	3482	3483	3484	3485	3486	3487	3488	3489	8	20
151-	2160	2161	2162	2163	2164	2165	2166	2167	2168	2169	8	21
151-	2010	2011	2012	2013	2014	2015	2016	2017	2018	2019	8	19
151-	3410	3411	3412	3413	3414	3415	3416	3417	3418	3419	8	20
151-	2090	2091	2092	2093	2094	2095	2096	2097	2098	2099	8	19
151-	2170	2171	2172	2173	2174	2175	2176	2177	2178	2179	8	21
151-	3570	3571	3572	3573	3574	3575	3576	3577	3578	3579	8	22
151-	2040	2041	2042	2043	2044	2045	2046	2047	2048	2048	8	23
151-	3440	3441	3442	3443	3444	3445	3446	3447	3448	3449	8	24
151-	2120	2121	2122	2123	2124	2125	2126	2127	2128	2129	8	23
151-	3520	3521	3522	3523	3524	3525	3526	3527	3528	3529	8	24
151-	2200	2201	2202	2203	2204	2205	2206	2207	2208	2209	8	25
151-	2050	2051	2052	2053	2054	2055	2056	2057	2058	2059	8	23
151-	3450	3451	3452	3453	3454	3455	3456	3457	3458	3459	8	24
151-	2130	2131	2132	2133	2134	2135	2136	2137	2138	2139	8	23
151-	2210	2211	2212	2213	2214	2215	2216	2217	2218	2219	8	25
→	12	12	13	13	14	14	15	15	16	16		

Ordering

Add the four character prefix "151-" to the four digit numbers from the chart for complete code number.

Example:

151-2000 for an DH 36 with A2-flange, cyl. 1 in shaft, port size $\frac{7}{8}$ - 14 UNF and without drain connection.

Note: Orders will not be accepted without the four character prefix.

TECHNICAL DATA FOR DH WITH 1 IN CYLINDRICAL AND 1 IN-6B SPLINED SHAFT

Type		DH 36	DH 50	DH 80	DH 100	DH 125	DH 160	DH 200	DH 250	DH 315	DH 400	
Geometric displacement	cm ³ [in ³]	36.0 [2.20]	48.6 [2.97]	77.8 [4.76]	97.3 [5.95]	125.0 [7.65]	155.7 [9.53]	194.6 [11.91]	242.3 [14.83]	306.1 [18.73]	389.2 [23.82]	
Max. speed	min ⁻¹ [rpm]	cont.	1050	930	780	620	485	390	310	250	200	155
		int. ²⁾	1270	1090	975	780	605	485	390	315	245	195
Max. torque ¹⁾	Nm [lbf-in]	cont.	59 [520]	79 [700]	125 [1110]	158 [1400]	203 [1800]	235 [2080]	267 [2360]	305 [2700]	355 [3140]	410 [3630]
		int. ²⁾	76 [670]	106 [940]	163 [1440]	214 [1890]	270 [2390]	320 [2830]	360 [3190]	415 [3670]	470 [4160]	485 [4290]
Max. output	kW [hp]	cont.	5.8 [7.9]	6.8 [9.3]	8.8 [12.0]	8.8 [12.0]	8.8 [12.0]	8.1 [10.9]	7.4 [9.0]	6.6 [8.9]	6.0 [8.0]	5.5 [7.4]
		int. ²⁾	7.0 [9.5]	8.2 [11.2]	11.4 [15.5]	11.8 [16.0]	11.0 [15.0]	11.1 [14.1]	9.8 [13.1]	8.8 [11.8]	7.8 [10.5]	6.4 [8.6]
Max. pressure drop	bar [psi]	cont.	124 [1800]	124 [1800]	124 [1800]	124 [1800]	124 [1800]	117 [1700]	103 [1500]	97 [1400]	90 [1300]	83 [1200]
		int. ²⁾	166 [2400]	166 [2400]	166 [2400]	166 [2400]	166 [2400]	159 [2300]	141 [2050]	131 [1900]	121 [1750]	97 [1400]
Max. oil flow	l/min [US gal/min]	cont.	38 [10.0]	45 [11.9]	60 [15.9]	60 [15.9]	60 [15.9]	60 [15.9]	60 [15.9]	60 [15.9]	60 [15.9]	60 [15.9]
		int. ²⁾	45 [11.9]	55 [14.5]	75 [19.8]	75 [19.8]	75 [19.8]	75 [19.8]	75 [19.8]	75 [19.8]	7 [19.8]	75 [19.8]
Max. starting pressure with unloaded shaft	bar [psi]	10 [145]	10 [145]	10 [145]	10 [145]	10 [145]	10 [145]	7 [100]	7 [100]	7 [100]	7 [100]	
Min. starting torque	at max. press. drop cont.	53 [470]	72 [635]	115 [1020]	144 [1275]	185 [1640]	217 [1920]	240 [2125]	279 [2470]	330 [2920]	385 [3405]	
	at max. press. drop int. ¹⁾	66 [585]	96 [850]	154 [1360]	192 [1700]	247 [2185]	295 [2610]	327 [2895]	379 [3355]	444 [3930]	451 [3990]	
	Nm [lbf-in]											

Type		Max. inlet pressure	Max return pressure with drain line
DH 36 - 400	bar [psi]	138 [2000]	138 [2000]
	bar [psi]	172 [2500]	172 [2500]

¹⁾ 6B splined shaft is recommended for operating torque of 280 Nm [2500 lbf-in] or more.

²⁾ Intermittent operation: the permissible values may occur for max. 10% of every minute.

**MAX. PERMISSIBLE
 SHAFT SEAL PRESSURE**

DH with HPS and without drain connection:
 The shaft seal pressure equals the average of input pressure and return pressure.

$$P_{\text{seal}} = \frac{P_{\text{in}} + P_{\text{return}}}{2}$$

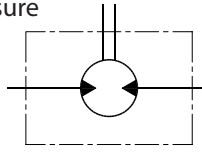

151-1743.10

DH with HPS and drain connection:
 The shaft seal pressure equals the pressure in the drain line.

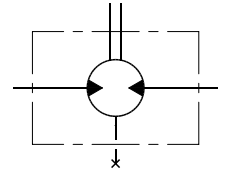

151-1855.10

Max. permissible shaft seal pressure

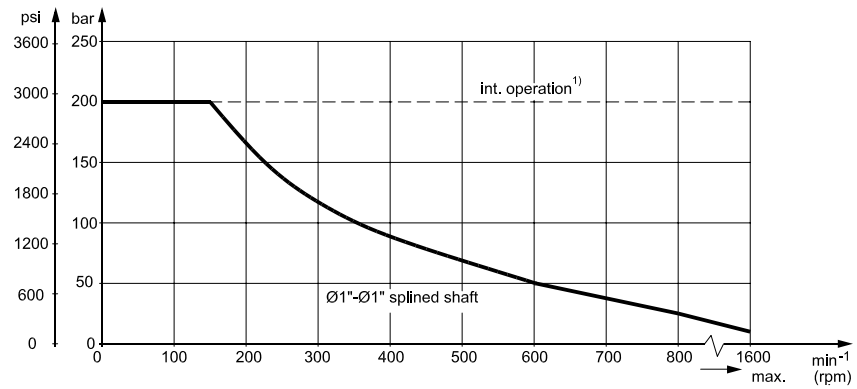

151-1872.10

**PRESSURE DROP IN
 MOTOR**

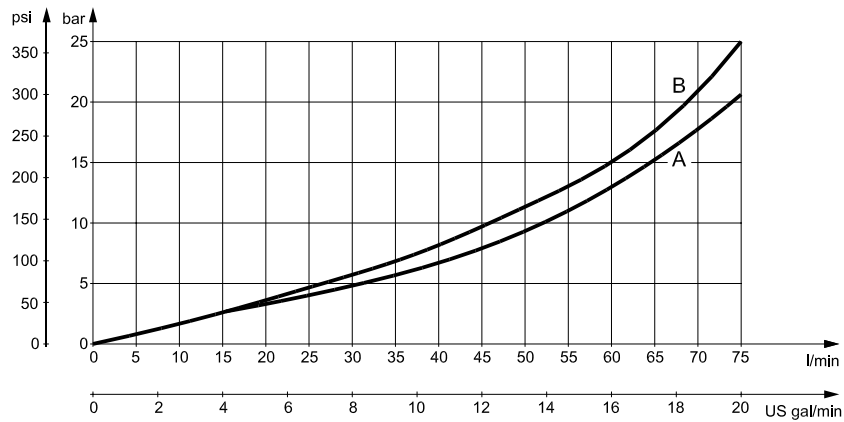

151-1873.10

The curve applies to an unloaded motor shaft and an oil viscosity of 35 mm²/s [165 SUS]

- A: DH 80 - 400
- B: DH 36-50

OIL FLOW IN DRAIN LINE

The table shows the max. oil flow in the drain line at a return pressure less than 5-10 bar [75-150 psi].

Pressure drop bar (psi)	Viscosity mm ² /s (SUS)	Oil flow in drain line l/min (US gal/min)
100 [1450]	20 [100]	2.5 [0.66]
	35 [165]	1.8 [0.78]
140 [2030]	20 [100]	3.5 [0.93]
	35 [165]	2.8 [0.74]

**DIRECTION OF SHAFT
 ROTATION**

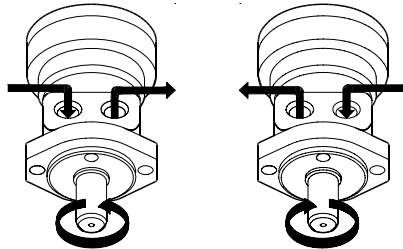

151-1874.10

PERMISSIBLE SHAFT LOADS FOR DH

The permissible radial shaft load (P_R) depends on

- speed (n)
- distance (l) from the point of load to the mounting flange
- mounting flange version
- shaft version

Mounting flange	Square flange 2-hole oval flange (US version)
Shaft version	1 in cylindrical shaft 1 in-6B splined shaft
Permissible shaft load (P_R) l in mm	$\frac{650}{n} \times \frac{228000}{87 + l} \text{ N}^*$
Permissible shaft load (P_R) l in inch	$\frac{1460}{n} \times \frac{898}{3.425 + l} \text{ lbf}^*$

* $n \geq 200 \text{ min}^{-1}$ (rpm); $l \leq 55 \text{ mm}$ [2.2 in]
 $n < 200 \text{ min}^{-1}$ (rpm); $\Rightarrow P_{R\text{max}} = 6500 \text{ N}$ [1460 lbf], when using above formulas n has to be 200 min^{-1} (rpm).

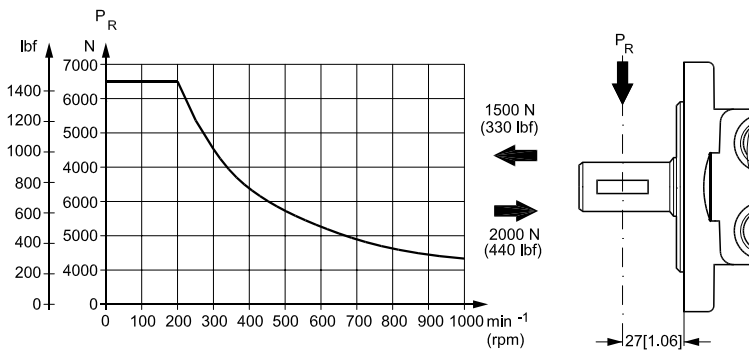

151-1875.10

The curve shows the relation between P_R and n

- when $l = 27 \text{ mm}$ [1.06 in] for motors with oval and square mounting flange

FUNCTION DIAGRAMS

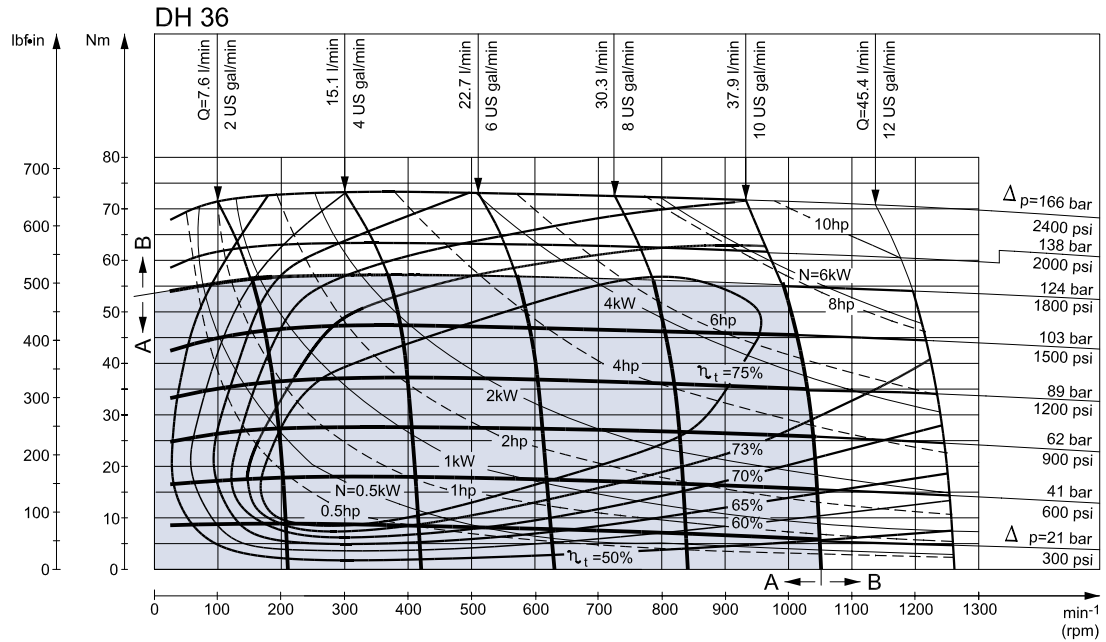

151-1910.10

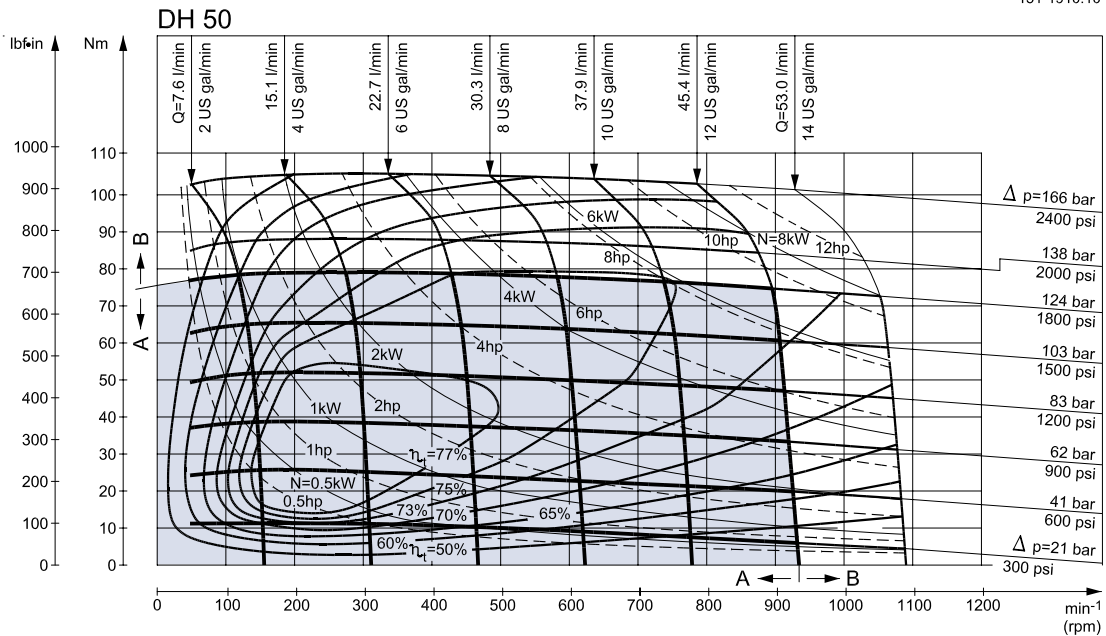

151-1901.10

Explanation of function diagram use, basis and conditions can be found on page 4.

- A: Continuous range
- B: Intermittent range (max. 10% operation every minute)

Max. permissible continuous/intermittent pressure drop for the actual shaft version can be found on page 8.

Note: Intermittent pressure drop and oil flow must not occur simultaneously.

FUNCTION DIAGRAMS

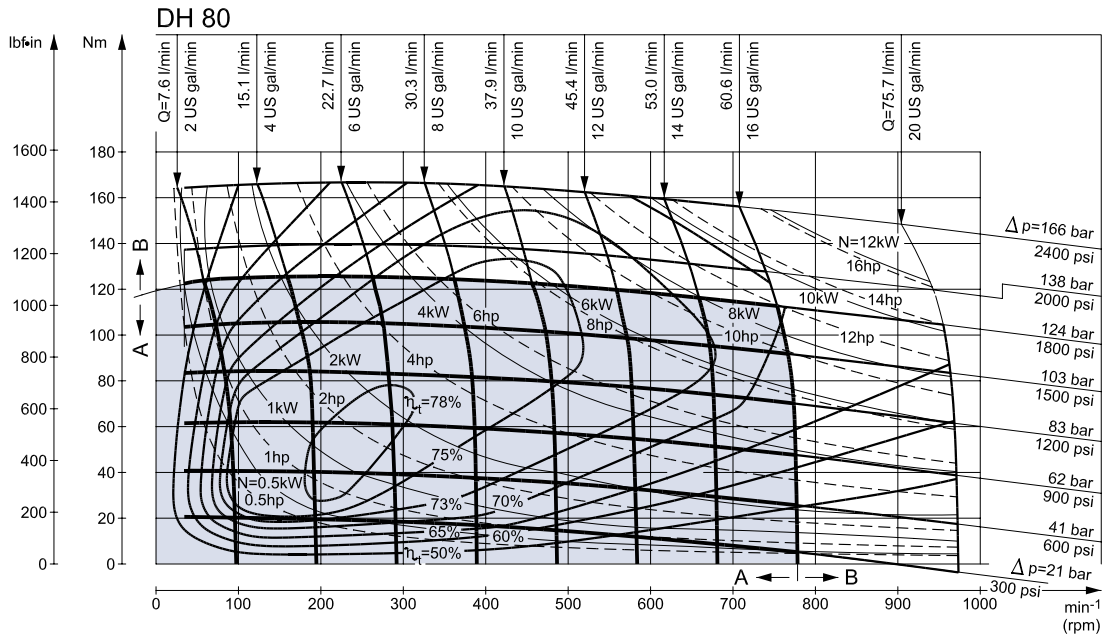

151-1902.10

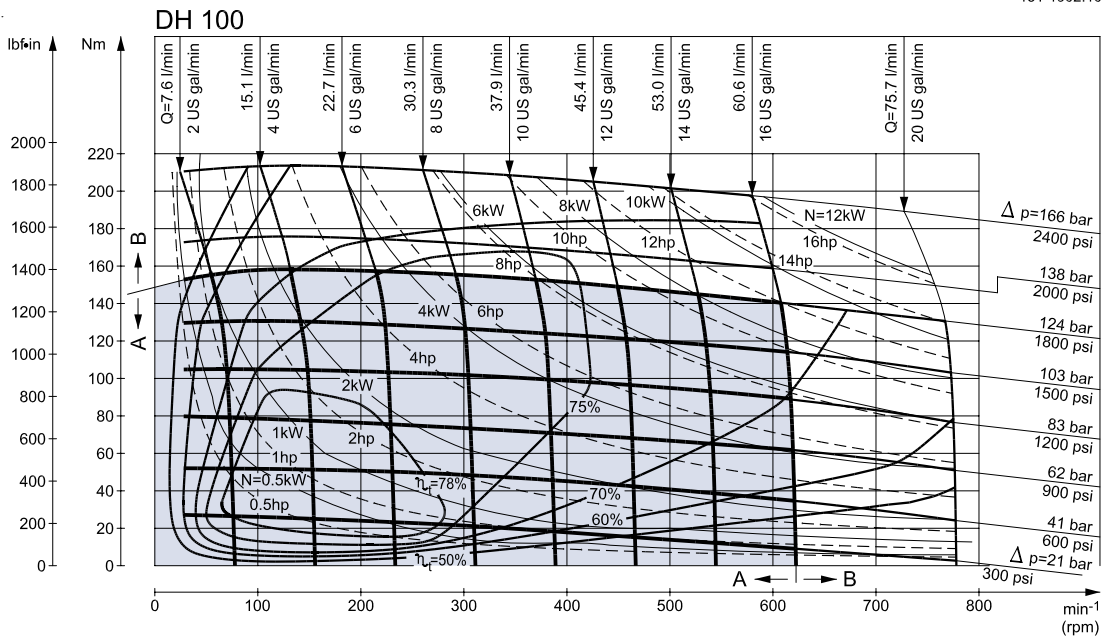

151-1903.10

Explanation of function diagram use, basis and conditions can be found on page 4.

- A: Continuous range
- B: Intermittent range (max. 10% operation every minute)

Max. permissible continuous/intermittent pressure drop for the actual shaft version can be found on page 8.

Note: Intermittent pressure drop and oil flow must not occur simultaneously.

FUNCTION DIAGRAMS

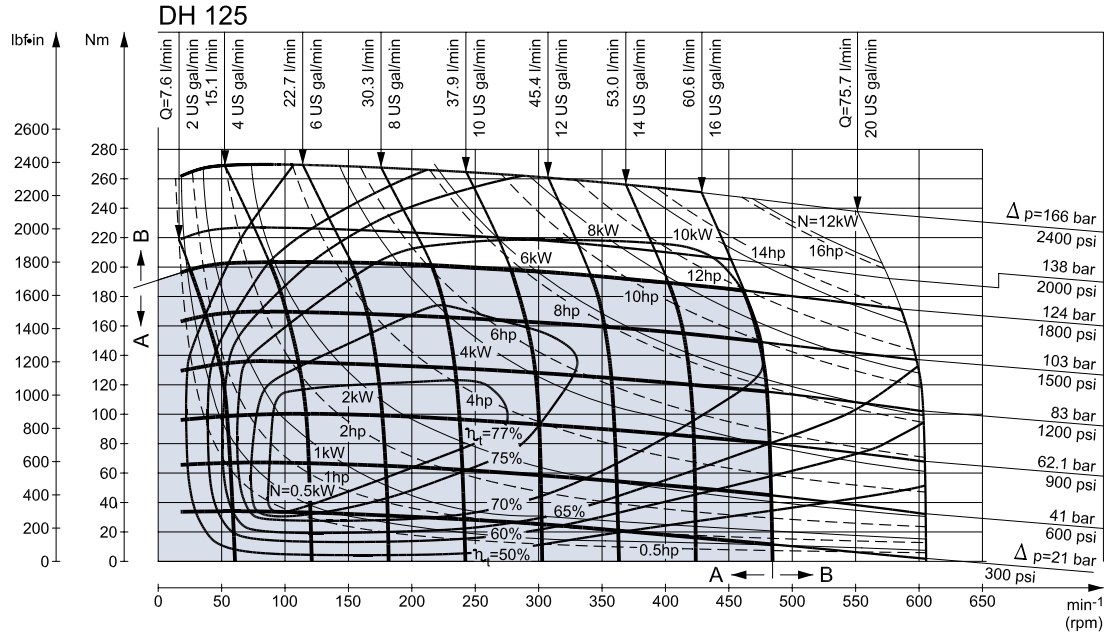

151-1904.10

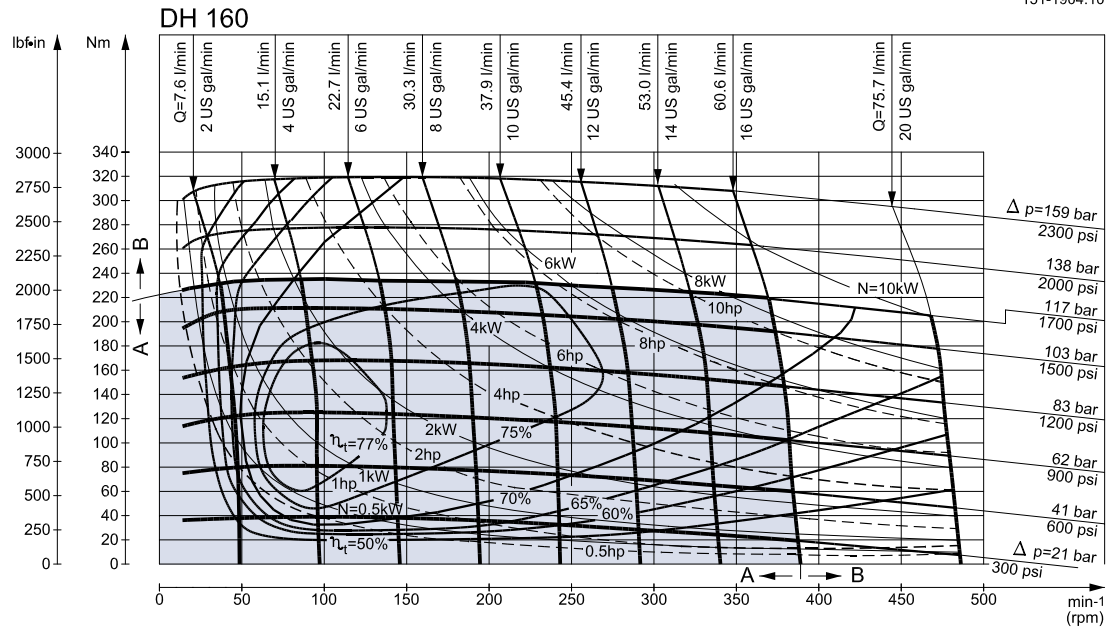

151-1885.10

Explanation of function diagram use, basis and conditions can be found on page 4.

- A: Continuous range
- B: Intermittent range (max. 10% operation every minute)

Max. permissible continuous/intermittent pressure drop for the actual shaft version can be found on page 8.

Note: Intermittent pressure drop and oil flow must not occur simultaneously.

FUNCTION DIAGRAMS

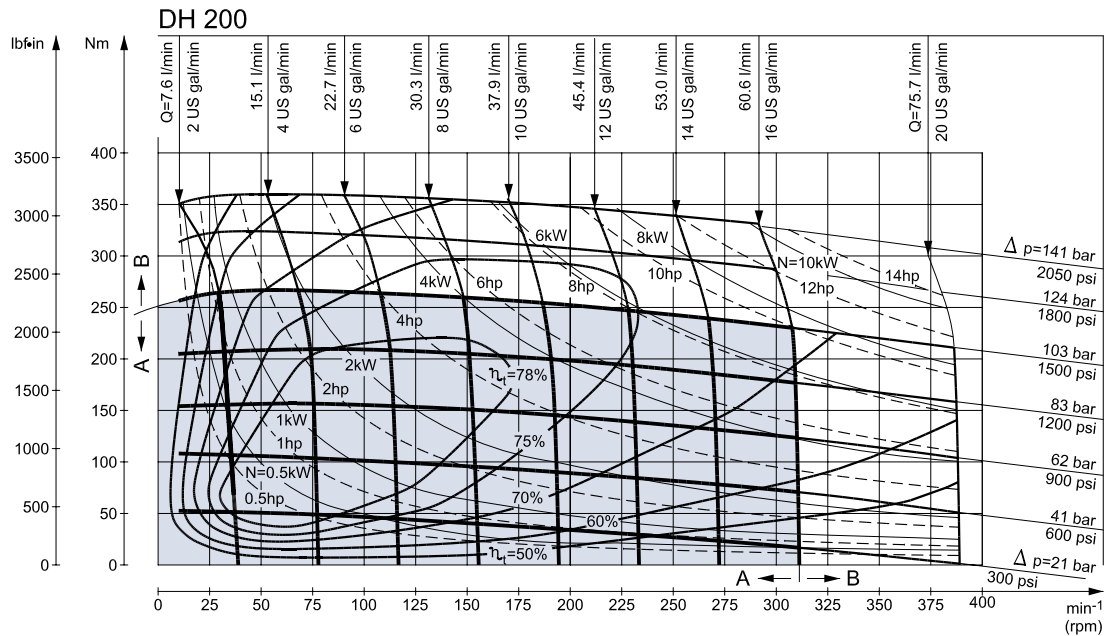

151-1905.10

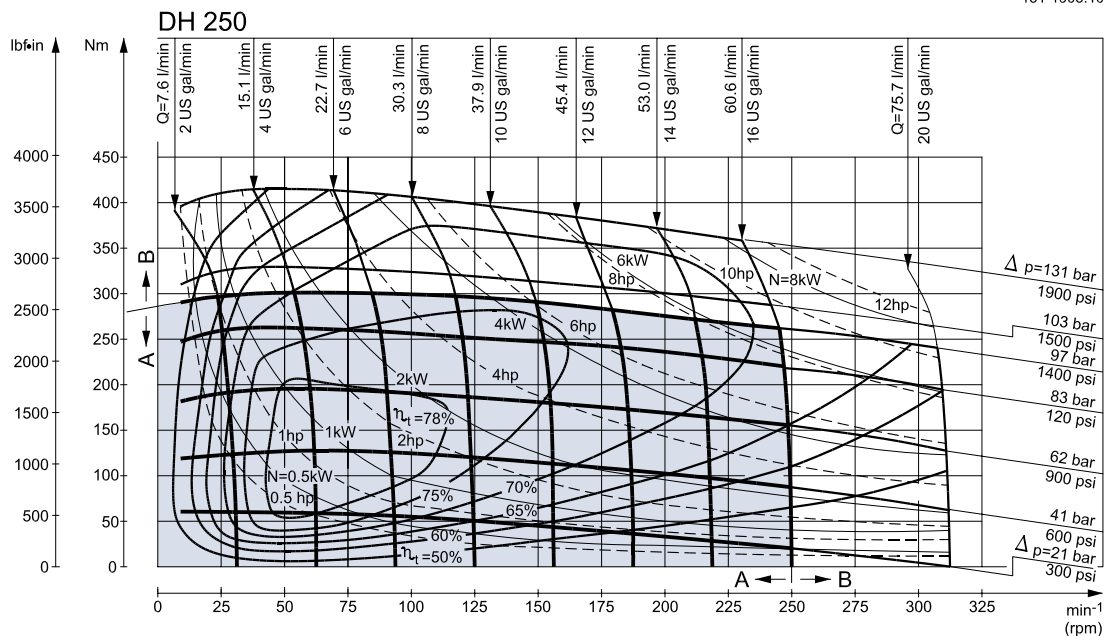

151-1906.10

Explanation of function diagram use, basis and conditions can be found on page 4.

- A: Continuous range
- B: Intermittent range (max. 10% operation every minute)

Max. permissible continuous/intermittent pressure drop for the actual shaft version can be found on page 8.

Note: Intermittent pressure drop and oil flow must not occur simultaneously.

FUNCTION DIAGRAMS

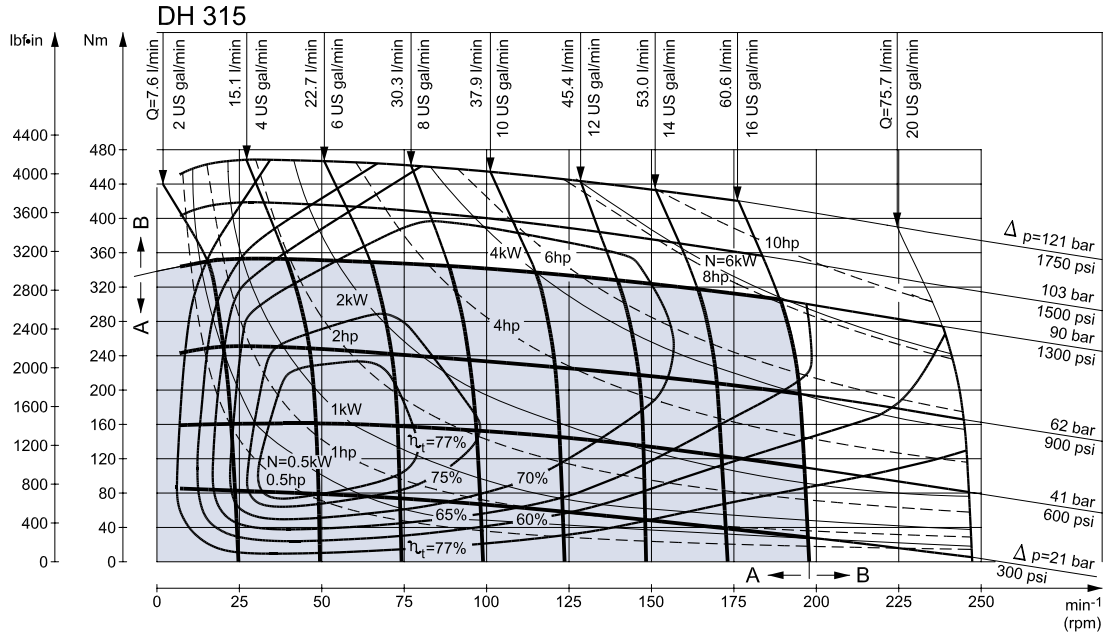

151-1907.10

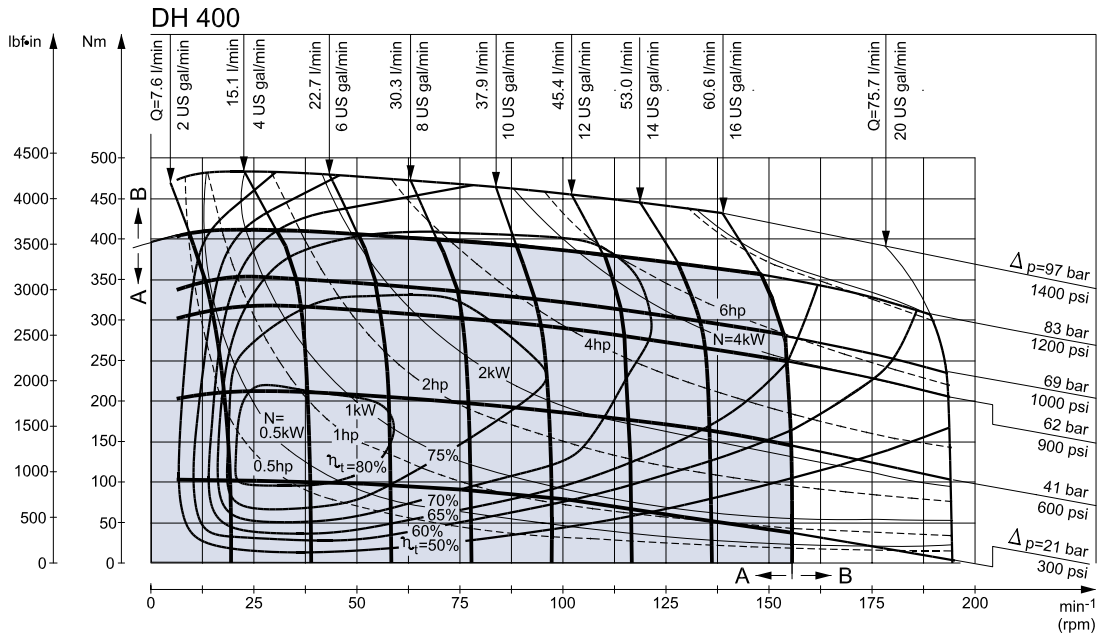

151-1908.10

Explanation of function diagram use, basis and conditions can be found on page 4.

- A: Continuous range
- B: Intermittent range (max. 10% operation every minute)

Max. permissible continuous/intermittent pressure drop for the actual shaft version can be found on page 8.

Note: Intermittent pressure drop and oil flow must not occur simultaneously.

SHAFT VERSION

US version

- A: Cylindrical shaft
1 in
- C: Parallel key
1/4 x 1 in
SAE J502

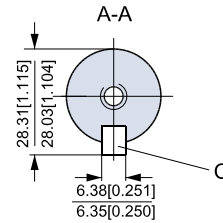
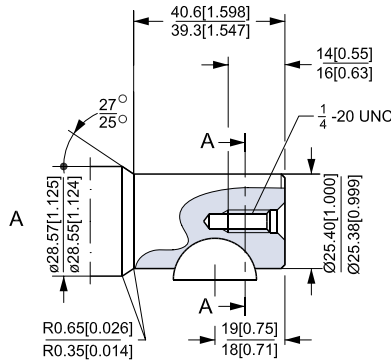

US version

- B: Splined shaft
1 in - SAE 6B
- C: Parallel key
1/4 x 1/4 x 1 1/4 in
B.S. 46
- * Deviates from B.S. 2059
(SAE 6B)

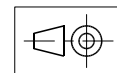
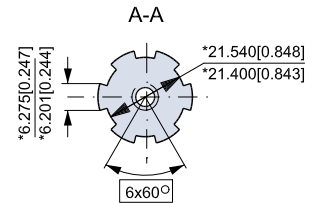
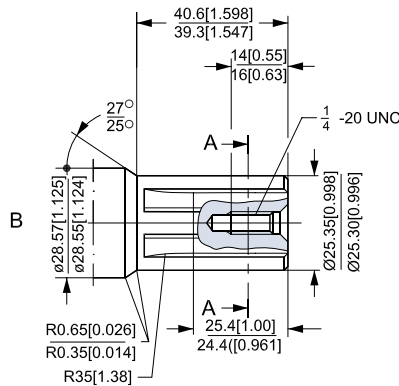

151-1876.10

Note: 6B splined shaft is recommended for operating torque of 280 Nm [2500 lbf-in] or more.

PORT THREAD VERSIONS

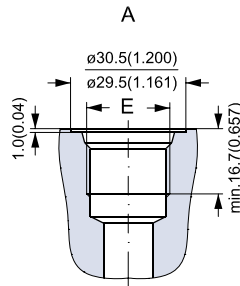

A: UNF main ports
E: 7/8 - 14 UNF
O-ring boss port

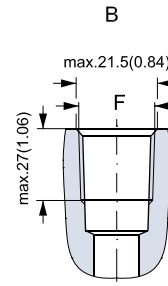

B: NPTF main ports
F: 1/2 - 14 NPTF

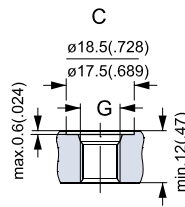

C: UNF drain port
G: 7/16 - 20 UNF
O-ring boss port

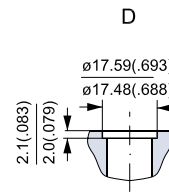

151-1881.10
D: Manifold main port

DIMENSIONS

Side port version with 2 hole oval mounting flange (A2-flange).
 Port thread version.

Type	L mm [in]	L ₁ mm [in]
DH 36	119.7 [4.71]	5.9 [0.23]
DH 50	120.3 [4.74]	6.5 [0.26]
DH 80	124.2 [4.89]	10.4 [0.41]
DH 100	126.8 [4.99]	13.0 [0.51]
DH 125	130.5 [5.14]	16.7 [0.66]
DH 160	134.6 [5.30]	20.8 [0.82]
DH 200	139.8 [5.50]	26.0 [1.02]
DH 250	146.3 [5.76]	32.5 [1.28]
DH 315	154.7 [6.09]	40.9 [1.61]
DH 400	165.8 [6.53]	52.0 [2.05]

D: 7/8 - 14 UNF,
 16.7 mm [0.66 in] deep
 O-ring boss port or
 1/2 - 14 NPTF

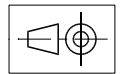
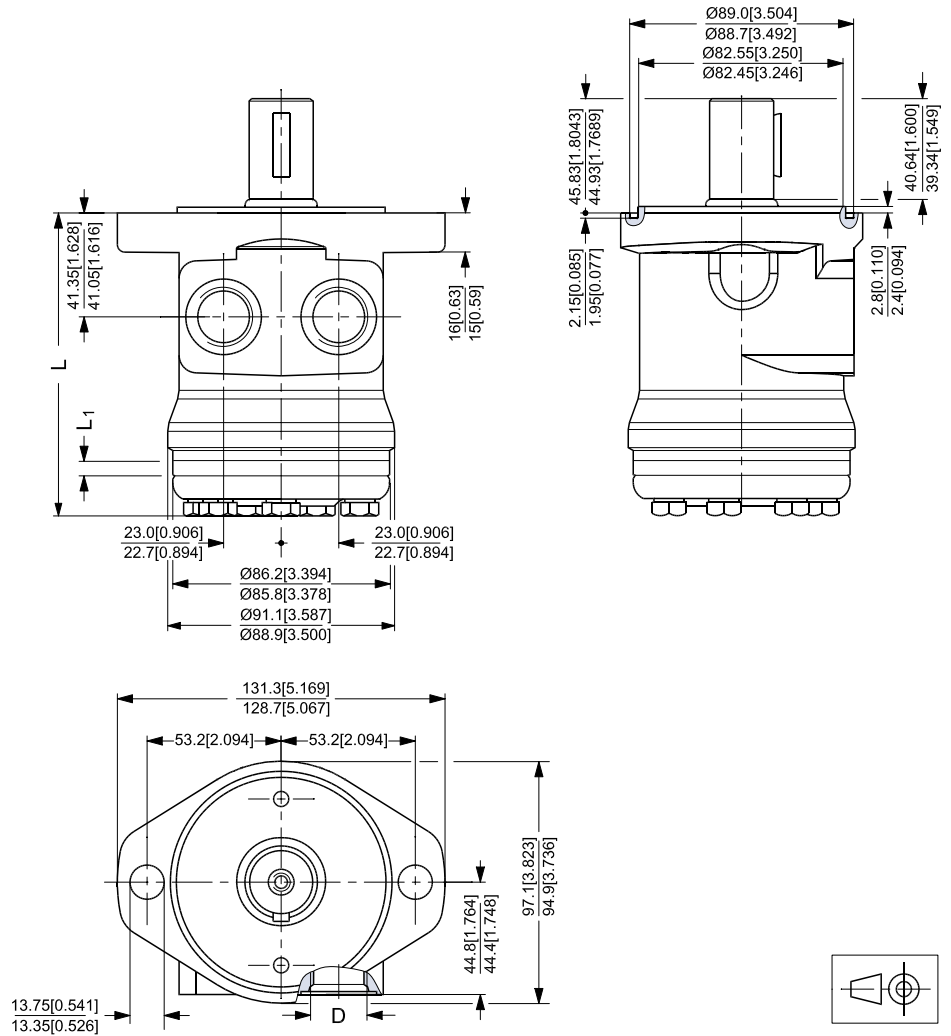

151-1877.10

DIMENSIONS

Side port version with 2 hole oval mounting flange (A2-flange).
 With drain connection.
 Port thread version.

Type	L mm [in]	L ₁ mm [in]
DH 36	119.7 [4.71]	5.9 [0.23]
DH 50	120.3 [4.74]	6.5 [0.26]
DH 80	124.2 [4.89]	10.4 [0.41]
DH 100	126.8 [4.99]	13.0 [0.51]
DH 125	130.5 [5.14]	16.7 [0.66]
DH 160	134.6 [5.30]	20.8 [0.82]
DH 200	139.8 [5.50]	26.0 [1.02]
DH 250	146.3 [5.76]	32.5 [1.28]
DH 315	154.7 [6.09]	40.9 [1.61]
DH 400	165.8 [6.53]	52.0 [2.05]

C: 7/16 - 20 UNF,
 12 mm [0.47 in] deep
 D: 7/8 - 14 UNF,
 16.7 mm [0.66 in] deep
 O-ring boss port or
 1/2 - 14 NPTF

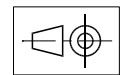
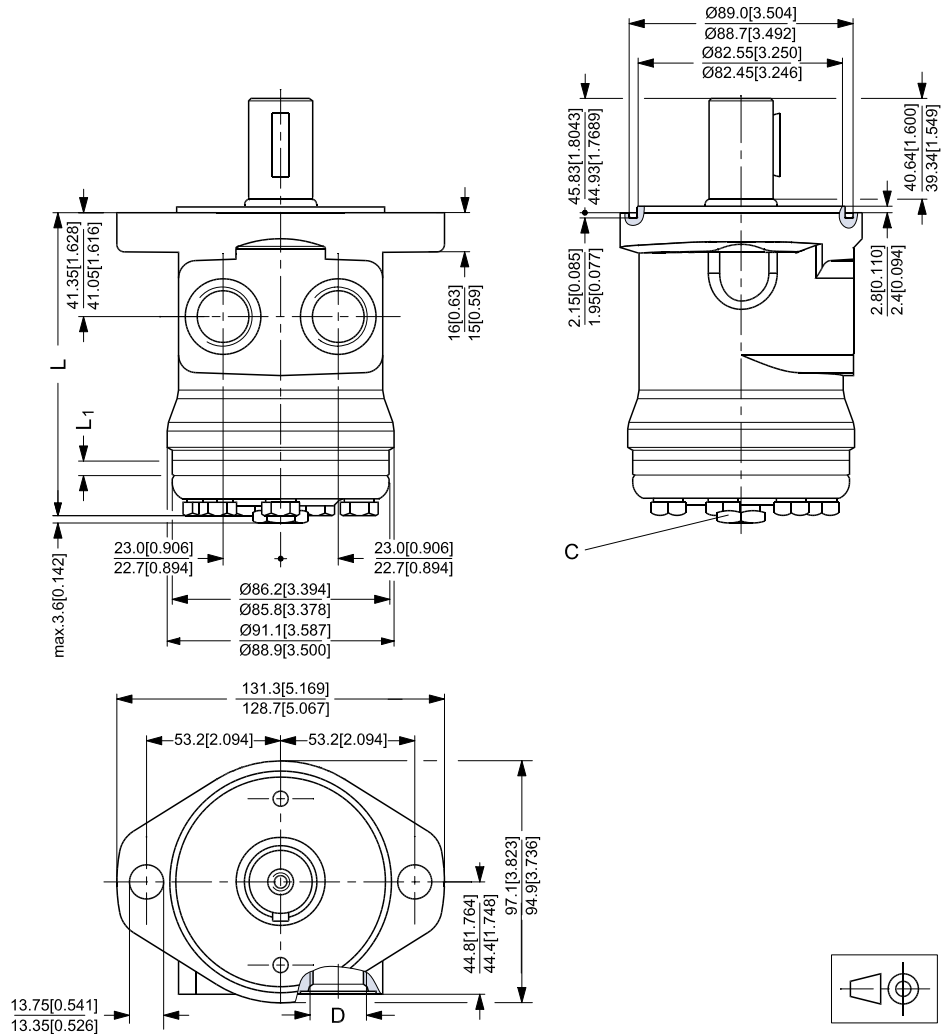

151-1890.10

DIMENSIONS

Side port version with 2 hole oval mounting flange (A2-flange).
 Manifold version.

Type	L mm [in]	L ₁ mm [in]
DH 36	119.7 [4.71]	5.9 [0.23]
DH 50	120.3 [4.74]	6.5 [0.26]
DH 80	124.2 [4.89]	10.4 [0.41]
DH 100	126.8 [4.99]	13.0 [0.51]
DH 125	130.5 [5.14]	16.7 [0.66]
DH 160	134.6 [5.30]	20.8 [0.82]
DH 200	139.8 [5.50]	26.0 [1.02]
DH 250	146.3 [5.76]	32.5 [1.28]
DH 315	154.7 [6.09]	40.9 [1.61]
DH 400	165.8 [6.53]	52.0 [2.05]

D: 2 × Ø17.48 mm [0.69 in]
 E: 4 × ⁵/₁₆- 18 UNC;
 13 mm [0.51 in] deep

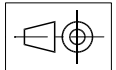
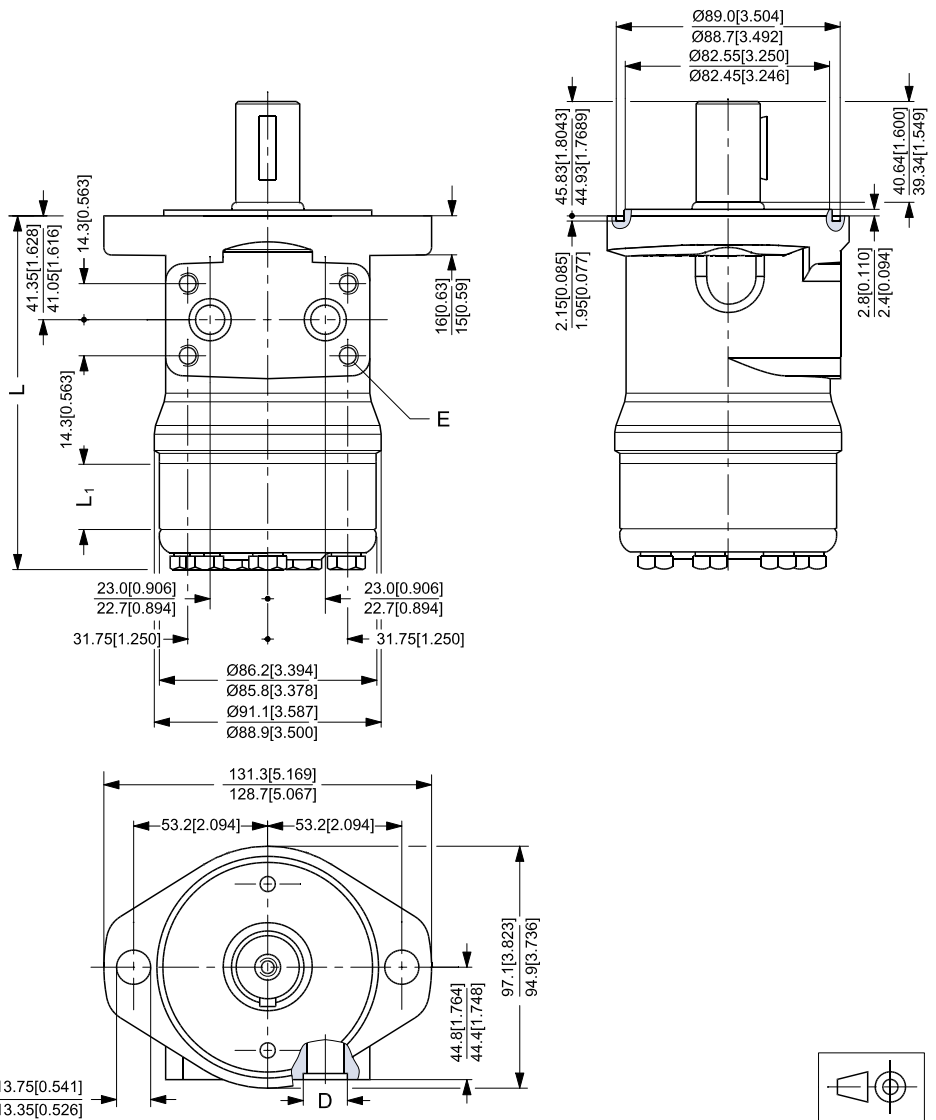

151-1878.10

DIMENSIONS

Side port version with 2 hole oval mounting flange (A2-flange).
 With drain connection.
 Manifold version.

Type	L mm [in]	L ₁ mm [in]
DH 36	119.7 [4.71]	5.9 [0.23]
DH 50	120.3 [4.74]	6.5 [0.26]
DH 80	124.2 [4.89]	10.4 [0.41]
DH 100	126.8 [4.99]	13.0 [0.51]
DH 125	130.5 [5.14]	16.7 [0.66]
DH 160	134.6 [5.30]	20.8 [0.82]
DH 200	139.8 [5.50]	26.0 [1.02]
DH 250	146.3 [5.76]	32.5 [1.28]
DH 315	154.7 [6.09]	40.9 [1.61]
DH 400	165.8 [6.53]	52.0 [2.05]

C: 7/16 - 20 UNF,
 12 mm [0.47 in] deep
 D: 2 × Ø17.48 mm [0.69 in]
 E: 4 × 5/16 - 18 UNC;
 13 mm [0.51 in] deep

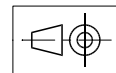
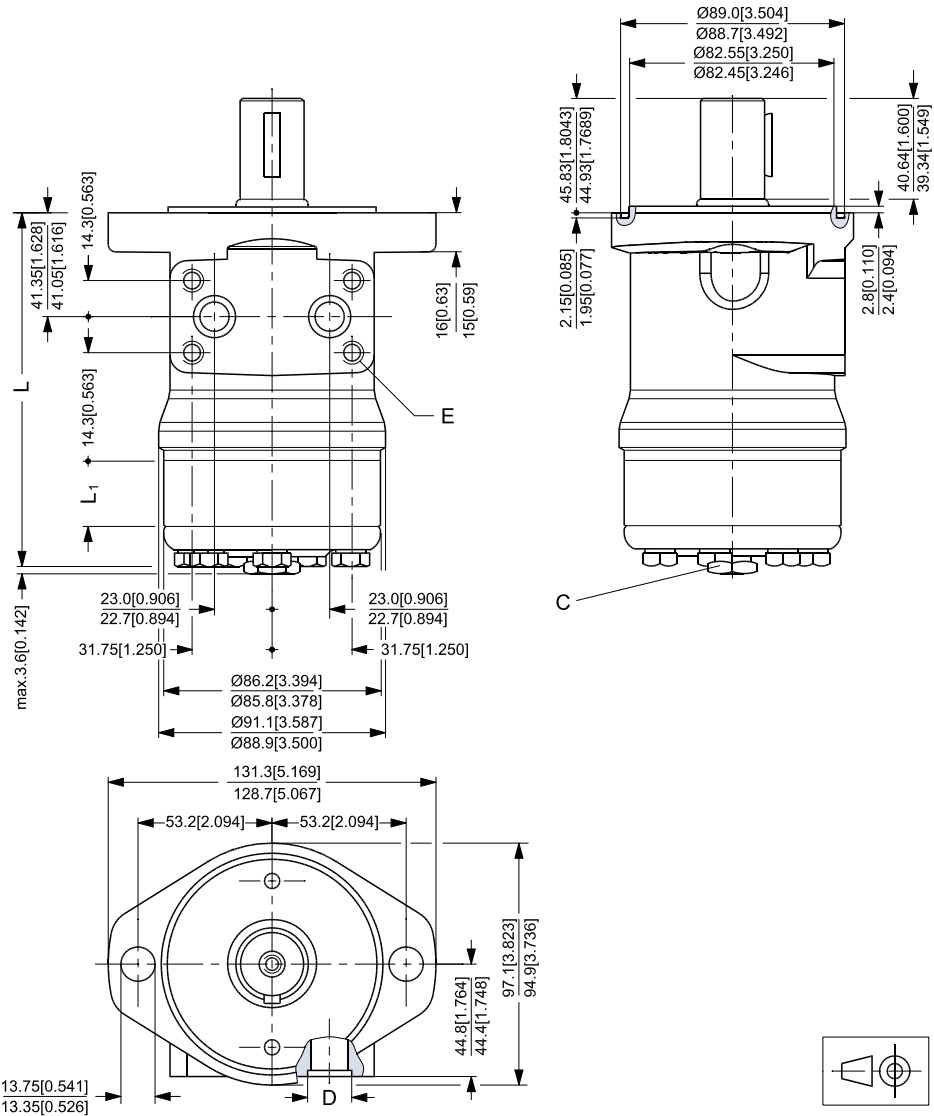

151-1891.10

DIMENSIONS

Side port version with square mounting flange (C-flange).
 Port thread version.

Type	L mm [in]	L ₁ mm [in]
DH 36	119.7 [4.71]	5.9 [0.23]
DH 50	120.3 [4.74]	6.5 [0.26]
DH 80	124.2 [4.89]	10.4 [0.41]
DH 100	126.8 [4.99]	13.0 [0.51]
DH 125	130.5 [5.14]	16.7 [0.66]
DH 160	134.6 [5.30]	20.8 [0.82]
DH 200	139.8 [5.50]	26.0 [1.02]
DH 250	146.3 [5.76]	32.5 [1.28]
DH 315	154.7 [6.09]	40.9 [1.61]
DH 400	165.8 [6.53]	52.0 [2.05]

D: 7/8 - 14 UNF;
 16.7 mm [0.66 in] deep
 or 1/2 - 14 NPTF
 E: 3/8 - 16 UNC;
 15 mm [0.59 in] deep
 (4-off)

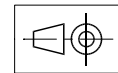
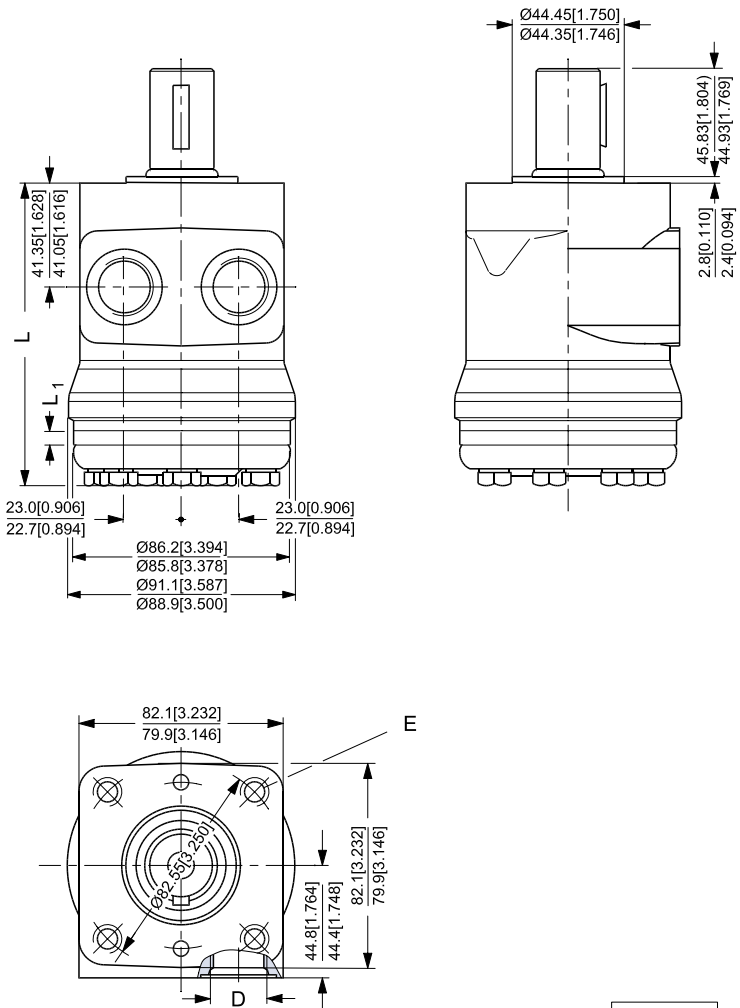

151-1879.10

DIMENSIONS

Side port version with square mounting flange (C-flange).
 Manifold version.

Type	L mm [in]	L ₁ mm [in]
DH 36	119.7 [4.71]	5.9 [0.23]
DH 50	120.3 [4.74]	6.5 [0.26]
DH 80	124.2 [4.89]	10.4 [0.41]
DH 100	126.8 [4.99]	13.0 [0.51]
DH 125	130.5 [5.14]	16.7 [0.66]
DH 160	134.6 [5.30]	20.8 [0.82]
DH 200	139.8 [5.50]	26.0 [1.02]
DH 250	146.3 [5.76]	32.5 [1.28]
DH 315	154.7 [6.09]	40.9 [1.61]
DH 400	165.8 [6.53]	52.0 [2.05]

- D: 2 × Ø17.48 mm [0.69 in]
- E: 3/8 - 16 UNC;
15 mm [0.59 in] deep
(4 off)
- F: 4 × 5/16 - 18 UNC;
13 mm [0.51 in] deep

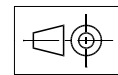
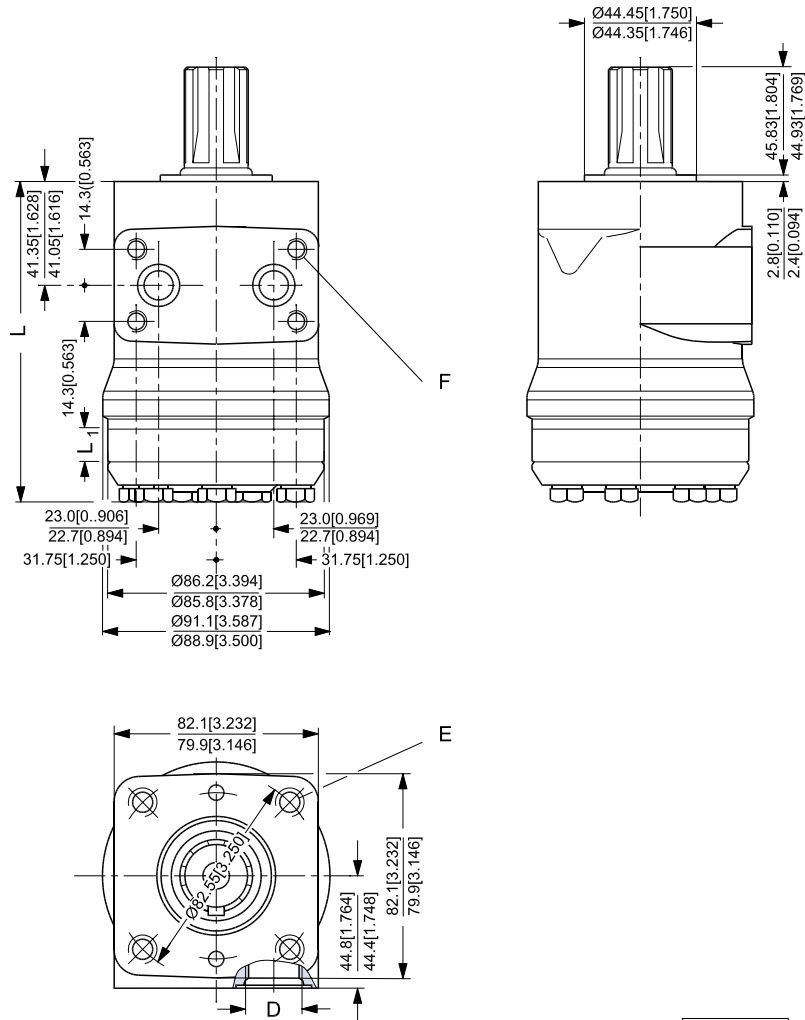

151-1880.10

VERSIONS

Mounting flange	Shaft	Port size	European version	US version	Side port version	End port version	Flange port version	Standard shaft seal	High pressure shaft seal	Drain connection	Check valve	Specials	Main type designation
2 hole oval flange (A2-flange)	Cyl. 1 in	7/8 - 14 UNF		<input type="radio"/>	<input type="radio"/>				<input type="radio"/>	No	No		DS
		7/8 - 14 UNF		<input type="radio"/>	<input type="radio"/>				<input type="radio"/>	Yes	No		DS
		1/2 - 14 NPTF		<input type="radio"/>	<input type="radio"/>				<input type="radio"/>	No	No		DS
		1/2 - 14 NPTF		<input type="radio"/>	<input type="radio"/>				<input type="radio"/>	Yes	No		DS
		Manifold		<input type="radio"/>	<input type="radio"/>				<input type="radio"/>	No	No		DS
	1 in - 6B spl.	7/8 - 14 UNF		<input type="radio"/>	<input type="radio"/>				<input type="radio"/>	No	No		DS
		7/8 - 14 UNF		<input type="radio"/>	<input type="radio"/>				<input type="radio"/>	Yes	No		DS
		1/2 - 14 NPTF		<input type="radio"/>	<input type="radio"/>				<input type="radio"/>	No	No		DS
		Manifold		<input type="radio"/>	<input type="radio"/>				<input type="radio"/>	No	No		DS
	Square flange (C-flange)	Cyl. 1 in	7/8 - 14 UNF		<input type="radio"/>	<input type="radio"/>				<input type="radio"/>	No	No	
7/8 - 14 UNF				<input type="radio"/>	<input type="radio"/>				<input type="radio"/>	Yes	No		DS
1/2 - 14 NPTF				<input type="radio"/>	<input type="radio"/>				<input type="radio"/>	No	No		DS
1/2 - 14 NPTF				<input type="radio"/>	<input type="radio"/>				<input type="radio"/>	Yes	No		DS
Manifold				<input type="radio"/>	<input type="radio"/>				<input type="radio"/>	No	No		DS
1 in - 6B spl.		7/8 - 14 UNF		<input type="radio"/>	<input type="radio"/>				<input type="radio"/>	No	No		DS
		1/2 - 14 NPTF		<input type="radio"/>	<input type="radio"/>				<input type="radio"/>	No	No		DS
		Manifold		<input type="radio"/>	<input type="radio"/>			<input type="radio"/>	No	No		DS	

Function diagram - see page : →

Features available (options) :
 1 in output shaft with cross hole
 Output shaft 7/8 - 13T splines
 Reverse rotation
 Drain port
 Painted

CODE NUMBERS

CODE NUMBERS	DISPLACEMENT [cm ³]									Technical data – Page	Dimensions – Page
	50	80	100	125	160	200	250	315	375		
151-	2301	2302	2303	2304	2305	2306	2307	2308	2309	28	39
151-	3701	3702	3703	3704	3705	3706	3707	3708	3709	28	40
151-	2381	2382	2383	2384	2385	2386	2387	2388	2389	28	39
151-	3781	3782	3783	3784	3785	3786	3787	3788	3789	28	40
151-	2461	2462	2463	2464	2465	2466	2467	2468	2469	28	41
151-	2311	2312	2313	2314	2315	2316	2317	2318	2319	28	39
151-	3711	3712	3713	3714	3715	3716	3717	3718	3719	28	40
151-	2391	2392	2393	2394	2395	2396	2397	2398	2399	28	39
151-	2471	2472	2473	2474	2475	2476	2477	2478	2479	28	40
151-	2341	2342	2343	2344	2345	2346	2347	2348	2349	28	42
151-	3741	3742	3743	3744	3745	3746	3747	3748	3749	28	43
151-	2421	2422	2423	2424	2425	2426	2427	2428	2429	28	42
151-	3821	3822	3823	3824	3825	3826	3827	3828	3829	28	43
151-	2501	2502	2503	2504	2505	2506	2507	2508	2509	28	44
151-	2351	2352	2353	2354	2355	2356	2357	2358	2359	28	42
151-	2431	2432	2433	2434	2435	2436	2437	2438	2439	28	42
151-	2511	2512	2513	2514	2515	2516	2517	2518	2519	28	44
→	32	32	33	33	34	34	35	35	36		

Ordering

Add the four character prefix "151-" to the four digit numbers from the chart for complete code number.

Example:

151-2305 for an DS 160 with A2-flange, cyl. 1 in shaft, port size $\frac{7}{8}$ - 14 UNF and without drain connection..

Note: Orders will not be accepted without the four character prefix.

TECHNICAL DATA FOR DS WITH 1 IN CYLINDRICAL AND 1 IN-6B SPLINED SHAFT

Type		DS	DS	DS	DS	DS	DS	DS	DS	DS	
Motor size		50	80	100	125	160	200	250	315	375	
Geometric displacement	cm ³ [in ³]	51.6 [3.16]	80.3 [4.91]	99.8 [6.11]	124.1 [7.60]	155.4 [9.51]	198.2 [12.13]	248.1 [15.18]	310.1 [18.98]	390.7 [23.91]	
Max. speed	min ⁻¹ [rpm]	cont.	770	755	605	480	380	305	245	190	155
		int. ²⁾	955	945	760	600	475	380	305	240	195
Max. torque ¹⁾	Nm [lbf-in]	cont.	93 [820]	159 [1405]	193 [1710]	247 [2190]	314 [2780]	350 [3100]	370 [3270]	415 [3670]	455 [4030]
		int. ²⁾	116 [1025]	206 [1820]	237 [2100]	304 [2690]	378 [3350]	429 [3800]	469 [4150]	485 [4290]	515 [4560]
Max. output	kW [hp]	cont.	6.6 [8.9]	10.7 [14.3]	10.7 [14.3]	10.7 [14.3]	10.7 [14.3]	9.6 [12.9]	8.0 [10.7]	6.9 [9.3]	5.8 [7.8]
		int. ²⁾	7.8 [10.5]	13.0 [17.4]	13.0 [17.4]	13.0 [17.4]	12.6 [16.9]	11.8 [15.8]	9.9 [13.3]	8.0 [10.7]	6.9 [9.3]
Max. pressure drop	bar [psi]	cont.	138 [2000]	138 [2000]	138 [2000]	138 [2000]	138 [2000]	124 [1800]	107 [1550]	97 [1400]	83 [1200]
		int. ²⁾	172 [2500]	172 [2500]	172 [2500]	172 [2500]	172 [2500]	155 [2250]	138 [2000]	114 [1650]	97 [1400]
Max. oil flow	l/min [US gal/min]	cont.	40 [10.6]	60 [15.9]	60 [15.9]	60 [15.9]	60 [15.9]	60 [15.9]	60 [15.9]	60 [15.9]	60 [15.9]
		int. ²⁾	50 [13.2]	75 [19.8]	75 [19.8]	75 [19.8]	75 [19.8]	75 [19.8]	75 [19.8]	75 [19.8]	75 [19.8]
Max. starting pressure with unloaded shaft	bar [psi]	10 [145]	10 [145]	10 [145]	10 [145]	10 [145]	10 [145]	7 [100]	7 [100]	7 [100]	
Min. starting torque	at max. press. drop cont.	76 [670]	118 [1045]	164 [1455]	204 [1810]	256 [2265]	294 [2600]	318 [2815]	358 [3170]	387 [3425]	
	at max. press. drop int. ¹⁾	95 [840]	148 [1305]	205 [1820]	255 [2260]	320 [2830]	367 [3250]	408 [3615]	423 [3745]	453 [4010]	
	Nm [lbf-in]										

Type		Max. inlet pressure	Max return pressure with drain line
DS 50 - 375	bar [psi]	138 [2000]	138 [2000]
	bar [psi]	172 [2500]	172 [2500]

¹⁾ 6B splined shaft is recommended for operating torque of 280 Nm [2500 lbf-in] or more.

²⁾ Intermittent operation: the permissible values may occur for max. 10% of every minute.

**MAX. PERMISSIBLE
 SHAFT SEAL PRESSURE**

DS with HPS and without drain connection:
 The shaft seal pressure equals the average of input pressure and return pressure.

$$P_{\text{seal}} = \frac{P_{\text{in}} + P_{\text{return}}}{2}$$

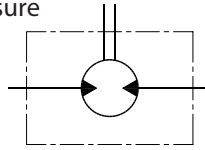

151-1743.10

DS with HPS and drain connection:
 The shaft seal pressure equals the pressure in the drain line.

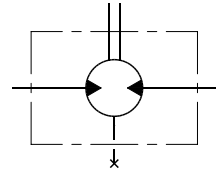

151-1855.10

Max. permissible shaft seal pressure

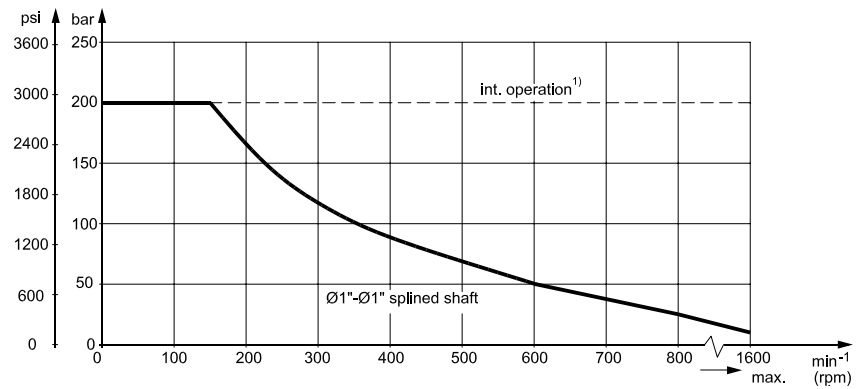

151-1872.10

**PRESSURE DROP IN
 MOTOR**

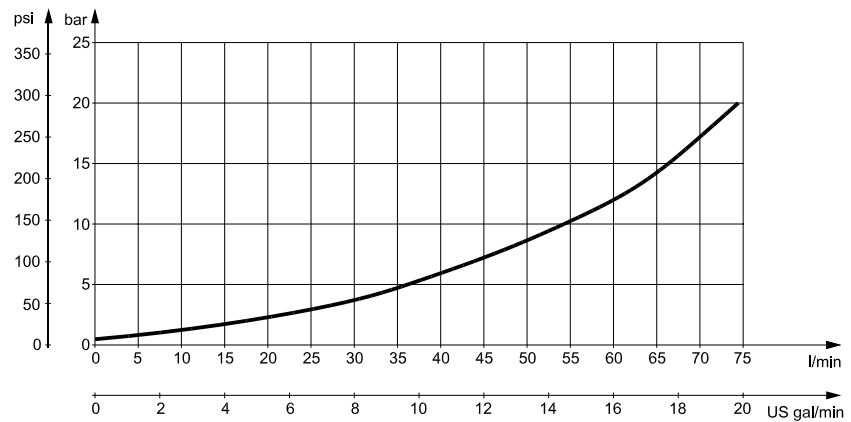

151-1913.10

The curve applies to an unloaded motor shaft and an oil viscosity of 35 mm²/s [165 SUS]

OIL FLOW IN DRAIN LINE

The table shows the max. oil flow in the drain line at a return pressure less than 5-10 bar [75-150 psi].

Pressure drop bar (psi)	Viscosity mm ² /s (SUS)	Oil flow in drain line l/min (US gal/min)
100 [1450]	20 [100]	2.5 [0.66]
	35 [165]	1.8 [0.78]
140 [2030]	20 [100]	3.5 [0.93]
	35 [165]	2.8 [0.74]

**DIRECTION OF SHAFT
ROTATION**

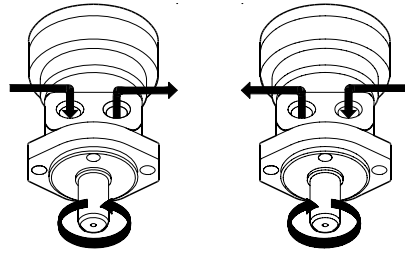

151-1874.10

PERMISSIBLE SHAFT LOADS FOR DS

The permissible radial shaft load (P_R) depends on

- speed (n)
- distance (l) from the point of load to the mounting flange
- mounting flange version
- shaft version

Mounting flange	Square flange 2-hole oval flange (US version)
Shaft version	1 in cylindrical shaft 1 in-6B splined shaft
Permissible shaft load (P_R) l in mm	$\frac{650}{n} \times \frac{228000}{87 + l}$ N*
Permissible shaft load (P_R) l in inch	$\frac{1460}{n} \times \frac{898}{3.425 + l}$ lbf*

* $n \geq 200 \text{ min}^{-1}$ (rpm); $l \leq 55 \text{ mm}$ [2.2 in]
 $n < 200 \text{ min}^{-1}$ (rpm); $\Rightarrow P_{R\text{max}} = 6500 \text{ N}$ [1460 lbf], when using above formulas n has to be 200 min^{-1} (rpm).

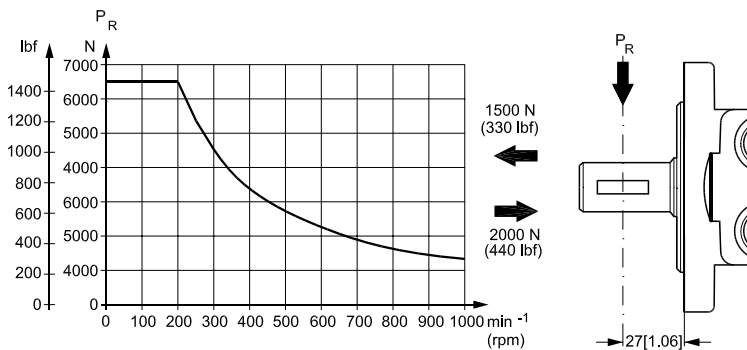

151-1875.10

The curve shows the relation between P_R and n

- when $l = 27 \text{ mm}$ [1.06 in] for motors with oval and square mounting flange

FUNCTION DIAGRAMS

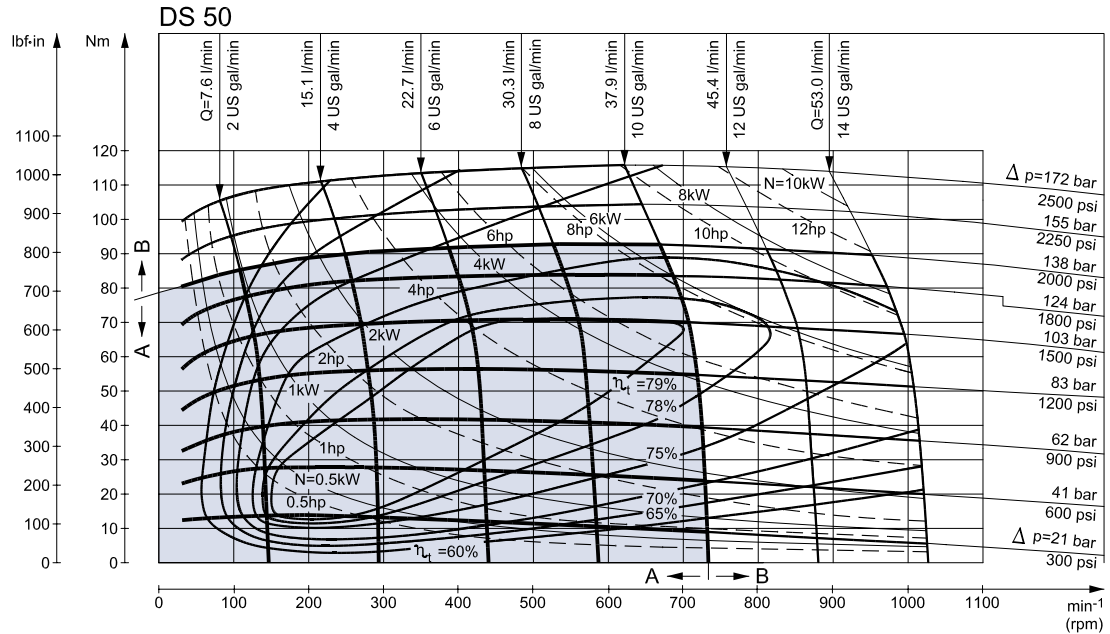

151-1909.10

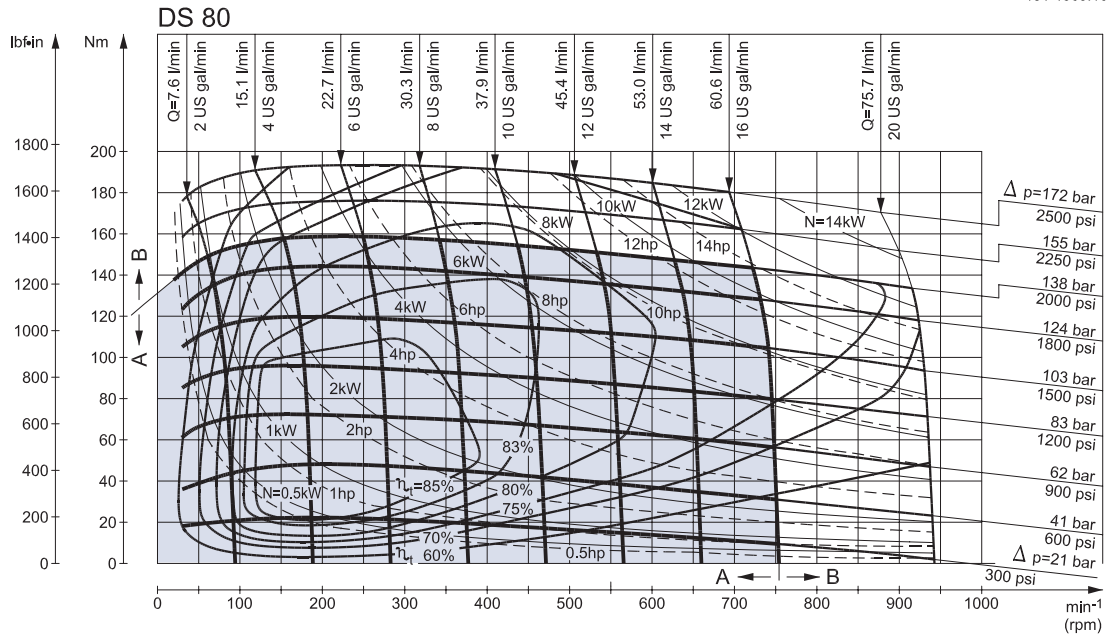

151-1900.10

Explanation of function diagram use, basis and conditions can be found on page 4.

- A: Continuous range
- B: Intermittent range (max. 10% operation every minute)

Max. permissible continuous/intermittent pressure drop for the actual shaft version can be found on page 28.

Note: Intermittent pressure drop and oil flow must not occur simultaneously.

FUNCTION DIAGRAMS

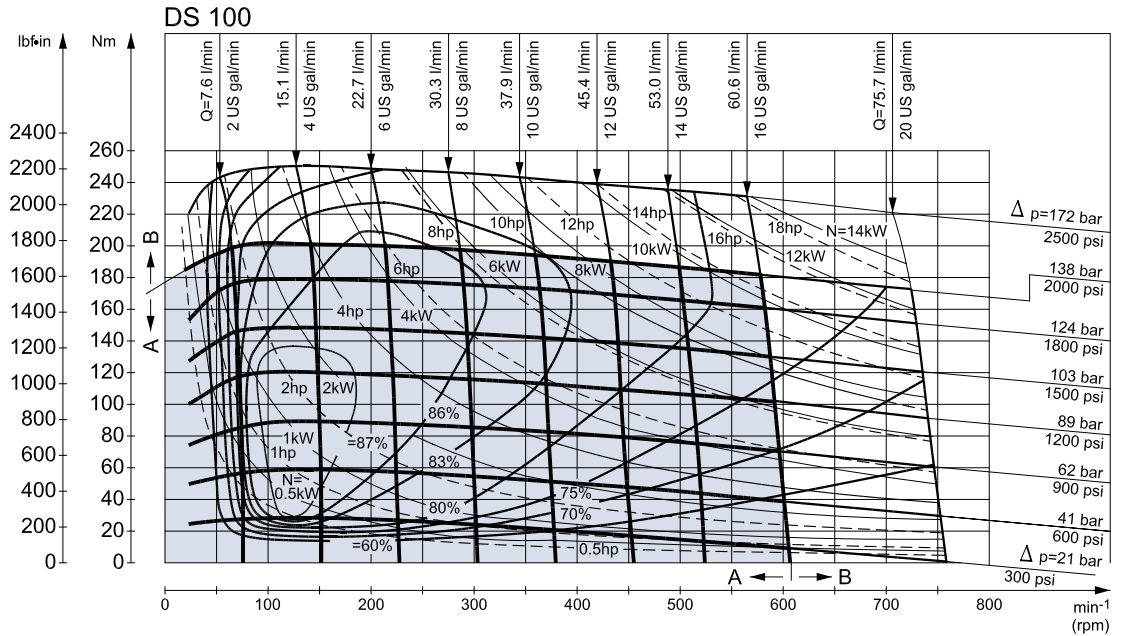

151-1889.10

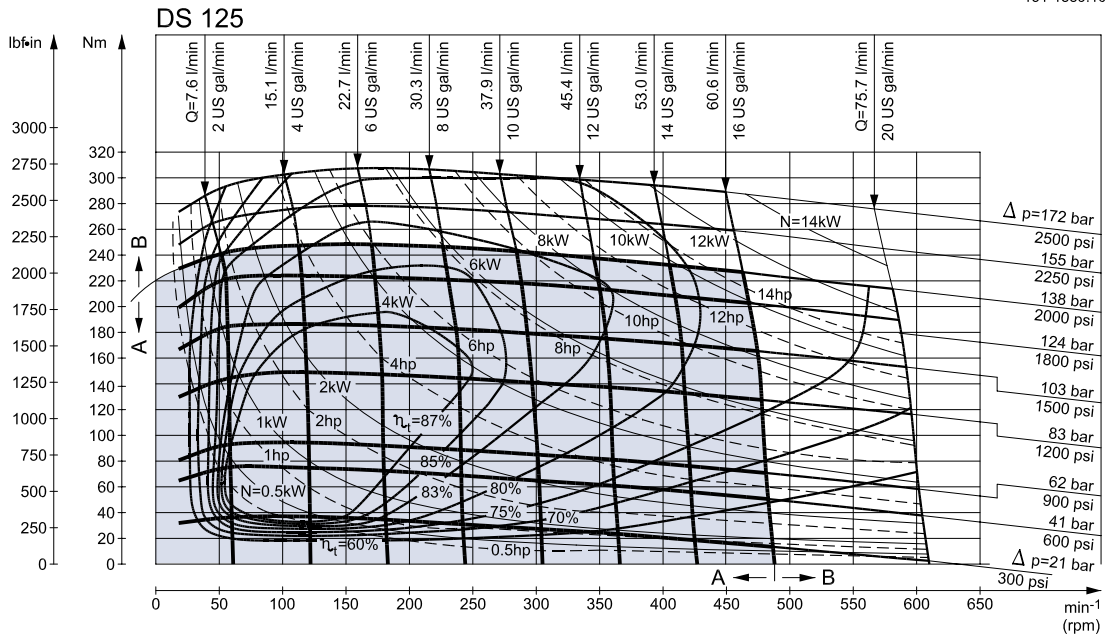

151-1886.10

Explanation of function diagram use, basis and conditions can be found on page 4.

- A: Continuous range
- B: Intermittent range (max. 10% operation every minute)

Max. permissible continuous/intermittent pressure drop for the actual shaft version can be found on page 28.

Note: Intermittent pressure drop and oil flow must not occur simultaneously.

FUNCTION DIAGRAMS

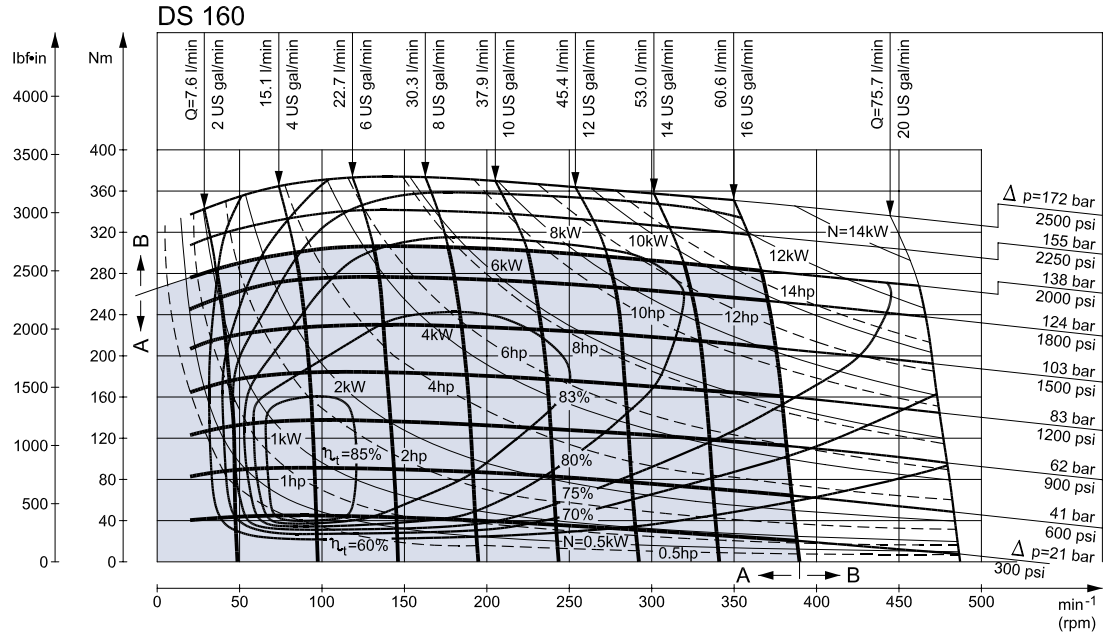

151-1883.10

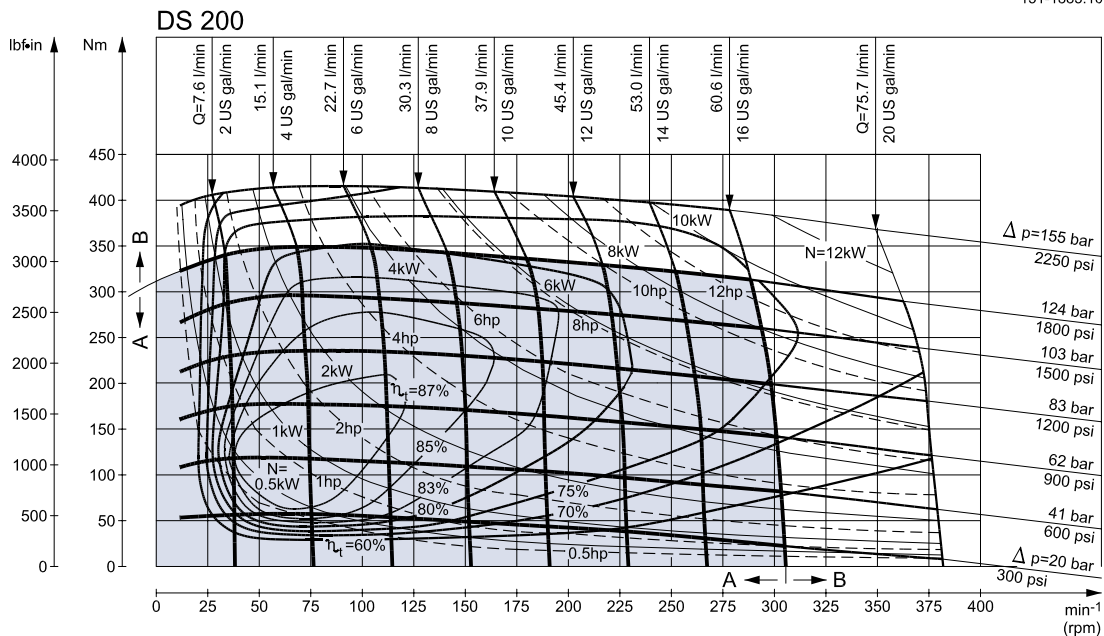

151-1887.10

Explanation of function diagram use, basis and conditions can be found on page 4.

- A: Continuous range
- B: Intermittent range (max. 10% operation every minute)

Max. permissible continuous/intermittent pressure drop for the actual shaft version can be found on page 28.

Note: Intermittent pressure drop and oil flow must not occur simultaneously.

FUNCTION DIAGRAMS

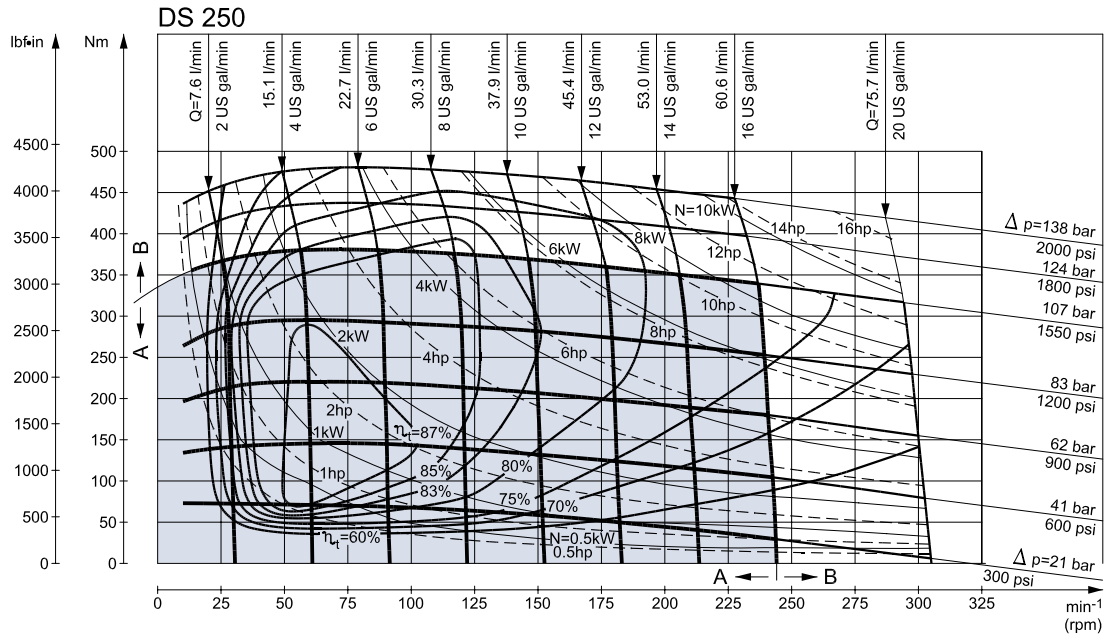

151-1884.10

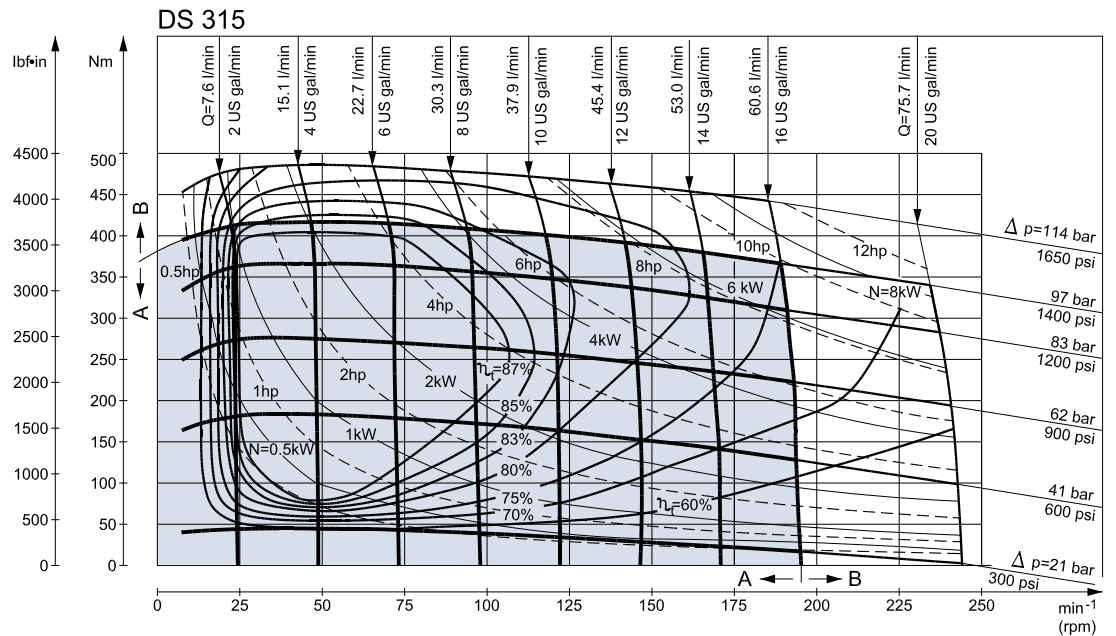

151-1888.10

Explanation of function diagram use, basis and conditions can be found on page 4.

- A: Continuous range
- B: Intermittent range (max. 10% operation every minute)

Max. permissible continuous/intermittent pressure drop for the actual shaft version can be found on page 28.

Note: Intermittent pressure drop and oil flow must not occur simultaneously.

FUNCTION DIAGRAMS

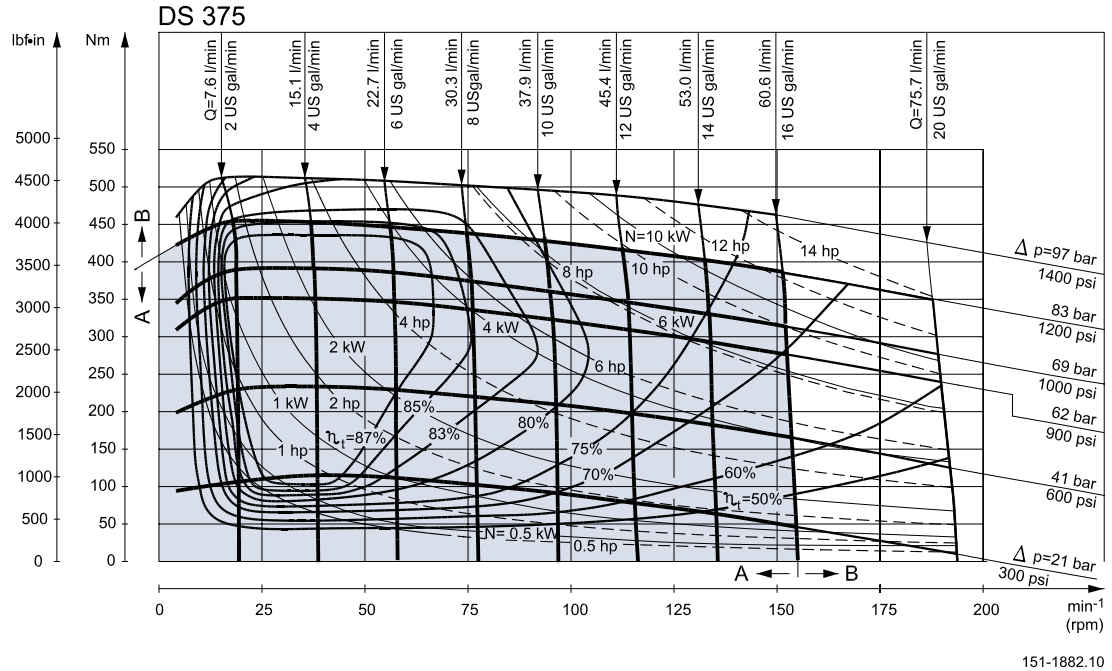

Explanation of function diagram use, basis and conditions can be found on page 4.

- A: Continuous range
- B: Intermittent range (max. 10% operation every minute)

Max. permissible continuous/intermittent pressure drop for the actual shaft version can be found on page 28.

Note: Intermittent pressure drop and oil flow must not occur simultaneously.

SHAFT VERSION

US version

- A: Cylindrical shaft
1 in
- C: Parallel key
1/4 × 1 in
SAE J502

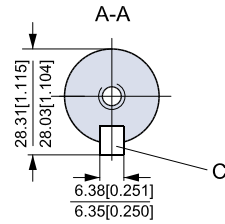
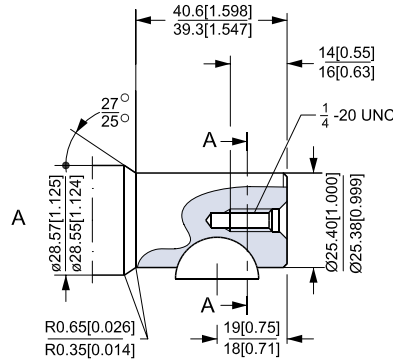

US version

- B: Splined shaft
1 in - SAE 6B
- C: Parallel key
1/4 × 1/4 × 1 1/4 in
B.S. 46
- * Deviates from B.S. 2059
(SAE 6B)

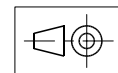
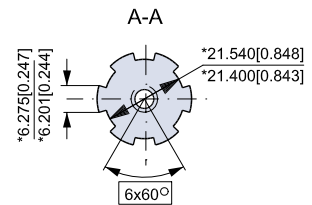
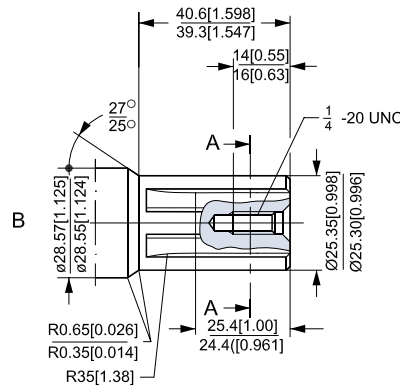

151-1876.10

Note: 6B splined shaft is recommended for operating torque of 280 Nm [2500 lbf-in] or more.

PORT THREAD VERSIONS

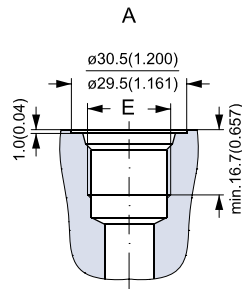

A: UNF main ports
E: 7/8 - 14 UNF
O-ring boss port

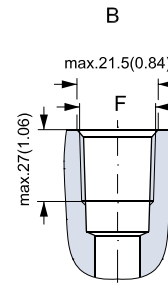

B: NPTF main ports
F: 1/2 - 14 NPTF

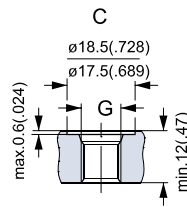

C: UNF drain port
G: 7/16 - 20 UNF
O-ring boss port

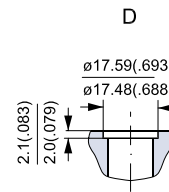

151-1881.10
D: Manifold main port

DIMENSIONS

Side port version with 2 hole oval mounting flange (A2-flange).
 Port thread version.

Type	L mm [in]	L ₁ mm [in]
DS 50	125.6 [4.94]	9.0 [0.35]
DS 80	130.6 [5.14]	14.0 [0.55]
DS 100	130.6 [5.14]	14.0 [0.55]
DS 125	134.0 [5.28]	17.4 [0.69]
DS 160	138.4 [5.45]	21.8 [0.86]
DS 200	144.4 [5.69]	27.8 [1.09]
DS 250	151.4 [5.96]	34.8 [1.37]
DS 315	160.1 [6.30]	43.5 [1.71]
DS 375	171.4 [6.75]	54.8 [2.16]

D: 7/8 - 14 UNF,
 16.7 mm [0.66 in] deep
 O-ring boss port or
 1/2 - 14 NPTF

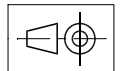
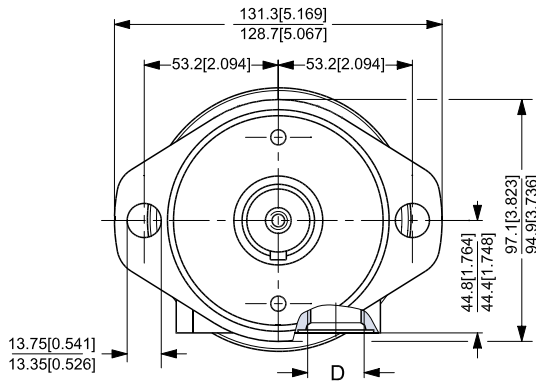
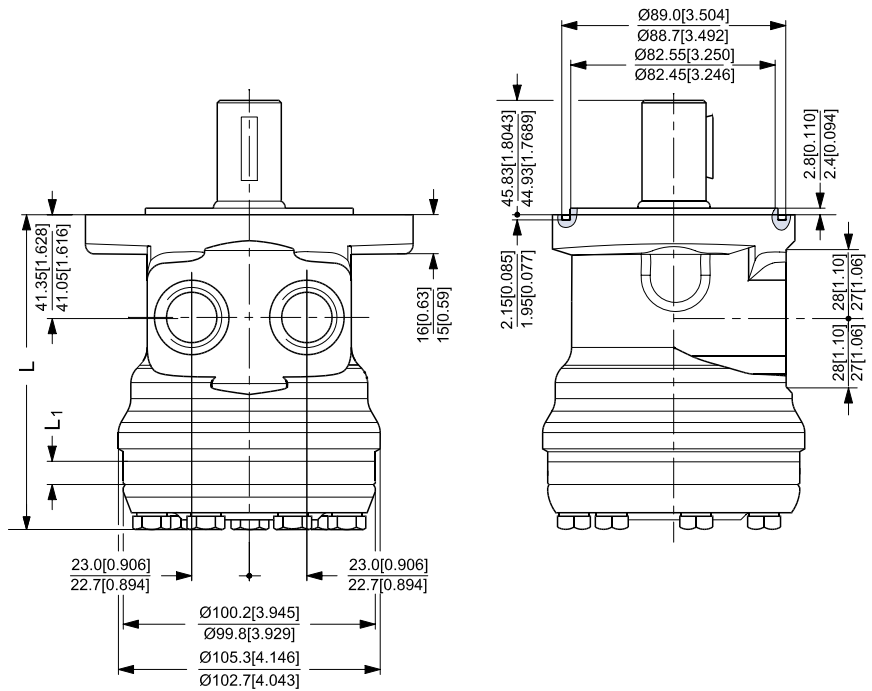

151-1898.10

DIMENSIONS

Side port version with 2 hole oval mounting flange (A2-flange).
 With drain connection.
 Port thread version.

Type	L mm [in]	L ₁ mm [in]
DS 50	125.6 [4.94]	9.0 [0.35]
DS 80	130.6 [5.14]	14.0 [0.55]
DS 100	130.6 [5.14]	14.0 [0.55]
DS 125	134.0 [5.28]	17.4 [0.69]
DS 160	138.4 [5.45]	21.8 [0.86]
DS 200	144.4 [5.69]	27.8 [1.09]
DS 250	151.4 [5.96]	34.8 [1.37]
DS 315	160.1 [6.30]	43.5 [1.71]
DS 375	171.4 [6.75]	54.8 [2.16]

C: 7/16 - 20 UNF,
 12 mm [0.47 in] deep
 D: 7/8 - 14 UNF,
 16.7 mm [0.66 in] deep
 O-ring boss port or
 1/2 - 14 NPTF

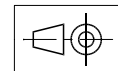
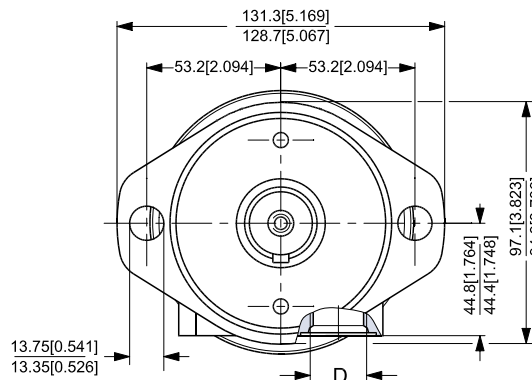
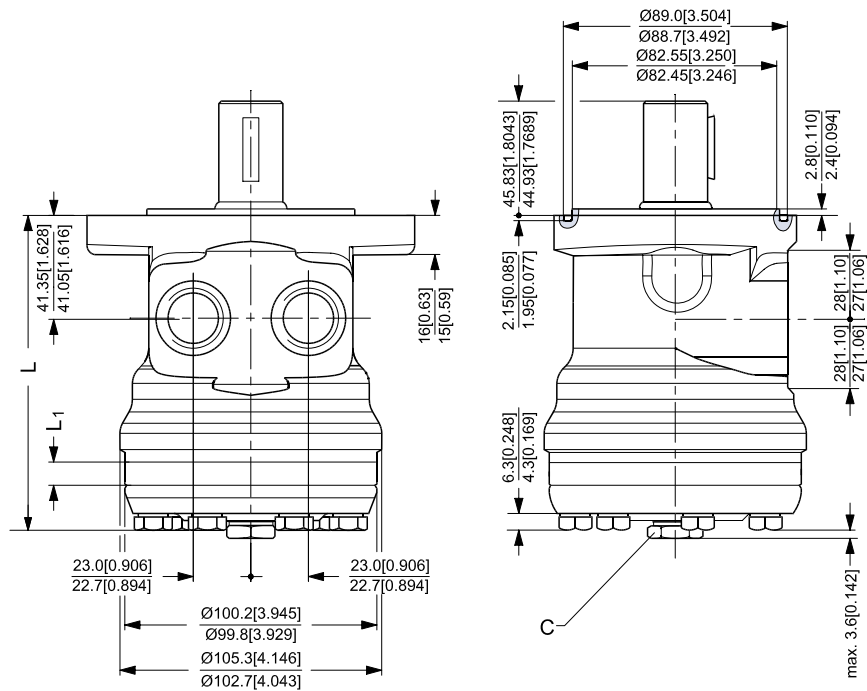

151-1899.10

DIMENSIONS

Side port version with 2 hole oval mounting flange (A2-flange).
 Manifold version.

Type	L mm [in]	L ₁ mm [in]
DS 50	125.6 [4.94]	9.0 [0.35]
DS 80	130.6 [5.14]	14.0 [0.55]
DS 100	130.6 [5.14]	14.0 [0.55]
DS 125	134.0 [5.28]	17.4 [0.69]
DS 160	138.4 [5.45]	21.8 [0.86]
DS 200	144.4 [5.69]	27.8 [1.09]
DS 250	151.4 [5.96]	34.8 [1.37]
DS 315	160.1 [6.30]	43.5 [1.71]
DS 375	171.4 [6.75]	54.8 [2.16]

D: 2 × Ø17.48 mm [0.69 in]
 E: 4 × ⁵/₁₆- 18 UNC;
 13 mm [0.51 in] deep
 (4 pcs.)

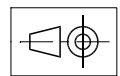
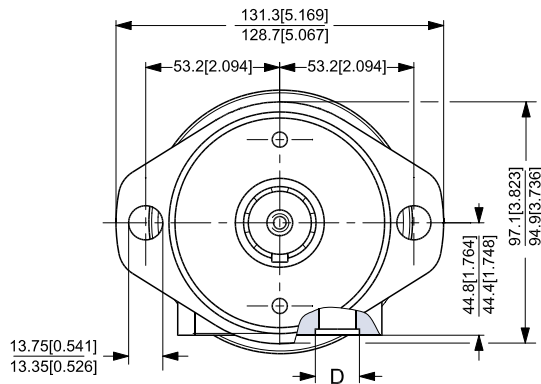
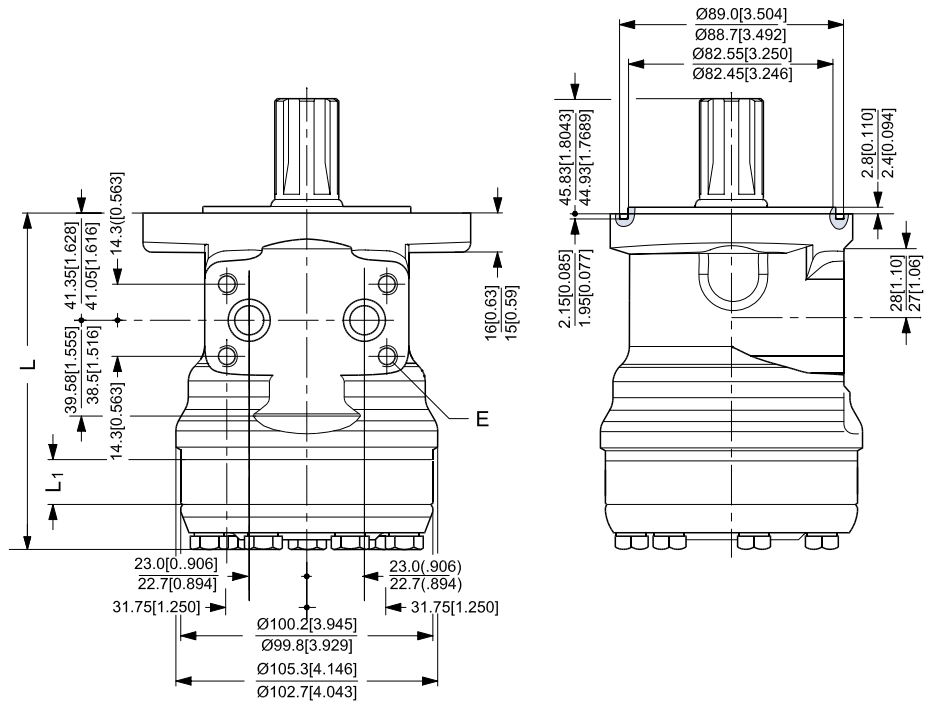

151-1895.10

DIMENSIONS

Side port version with square mounting flange (C-flange).
 Port thread version.

Type	L mm [in]	L ₁ mm [in]
DS 50	125.6 [4.94]	9.0 [0.35]
DS 80	130.6 [5.14]	14.0 [0.55]
DS 100	130.6 [5.14]	14.0 [0.55]
DS 125	134.0 [5.28]	17.4 [0.69]
DS 160	138.4 [5.45]	21.8 [0.86]
DS 200	144.4 [5.69]	27.8 [1.09]
DS 250	151.4 [5.96]	34.8 [1.37]
DS 315	160.1 [6.30]	43.5 [1.71]
DS 375	171.4 [6.75]	54.8 [2.16]

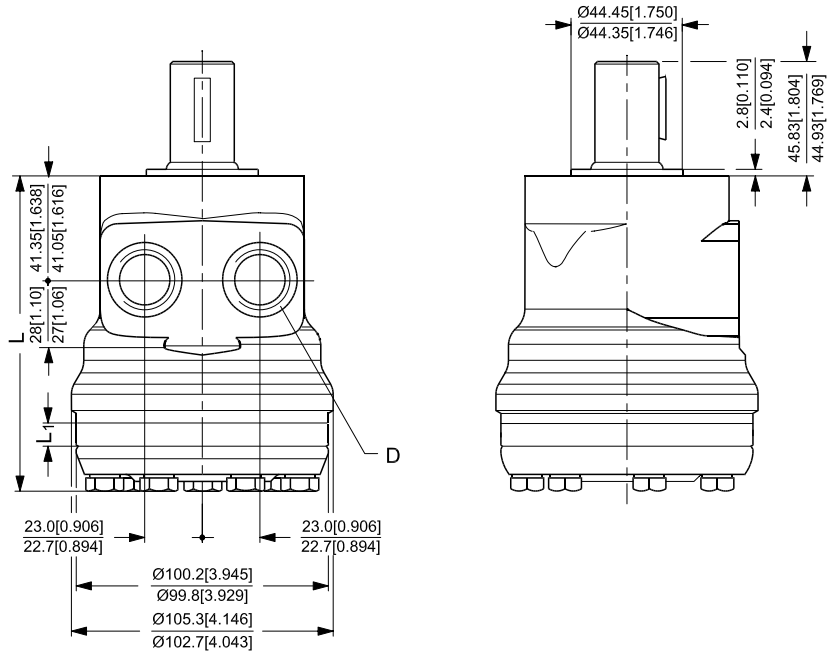

D: 7/8 - 14 UNF;
 16.7 mm [0.66 in] deep
 or 1/2 - 14 NPTF
 E: 3/8 - 16 UNC;
 15 mm [0.59 in] deep
 (4-off)

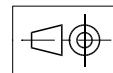
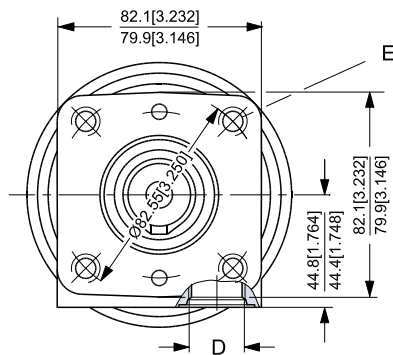

151-1897.10

DIMENSIONS

Side port version with square mounting flange (C-flange).
 With drain connection
 Port thread version.

Type	L mm [in]	L ₁ mm [in]
DS 50	125.6 [4.94]	9.0 [0.35]
DS 80	130.6 [5.14]	14.0 [0.55]
DS 100	130.6 [5.14]	14.0 [0.55]
DS 125	134.0 [5.28]	17.4 [0.69]
DS 160	138.4 [5.45]	21.8 [0.86]
DS 200	144.4 [5.69]	27.8 [1.09]
DS 250	151.4 [5.96]	34.8 [1.37]
DS 315	160.1 [6.30]	43.5 [1.71]
DS 375	171.4 [6.75]	54.8 [2.16]

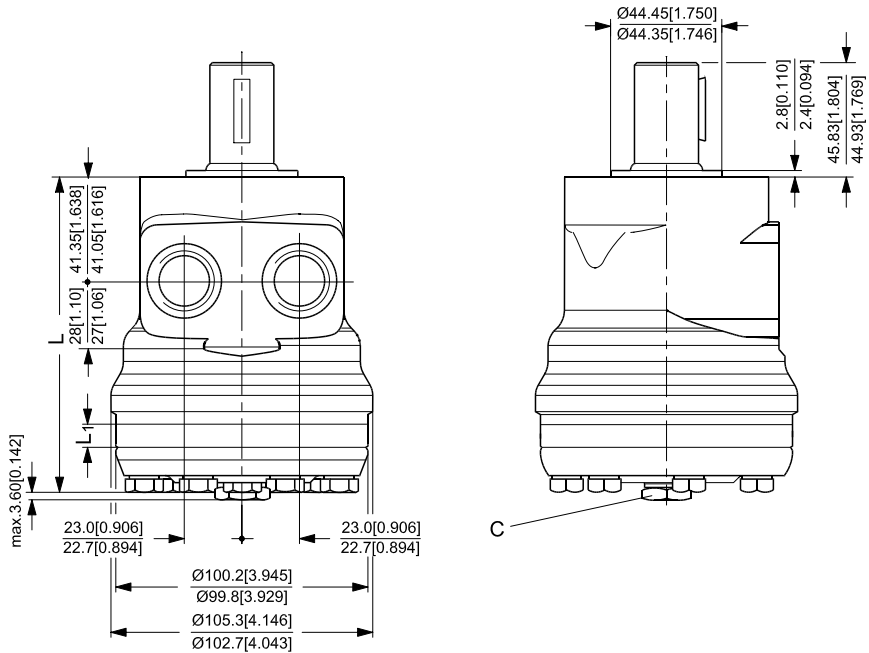

- C: 7/16 - 20 UNF,
12 mm [0.47 in] deep
- D: 7/8 - 14 UNF,
16.7 mm [0.66 in] deep
- E: 3/8 - 16 UNC,
15 mm [0.59 in] deep
(4-off)

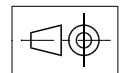
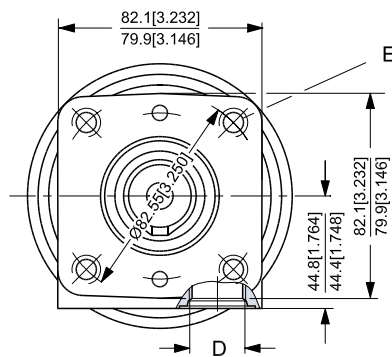

151-1896.10

DIMENSIONS

Side port version with square mounting flange (C-flange).
 Manifold version.

Type	L mm [in]	L ₁ mm [in]
DS 50	125.6 [4.94]	9.0 [0.35]
DS 80	130.6 [5.14]	14.0 [0.55]
DS 100	130.6 [5.14]	14.0 [0.55]
DS 125	134.0 [5.28]	17.4 [0.69]
DS 160	138.4 [5.45]	21.8 [0.86]
DS 200	144.4 [5.69]	27.8 [1.09]
DS 250	151.4 [5.96]	34.8 [1.37]
DS 315	160.1 [6.30]	43.5 [1.71]
DS 375	171.4 [6.75]	54.8 [2.16]

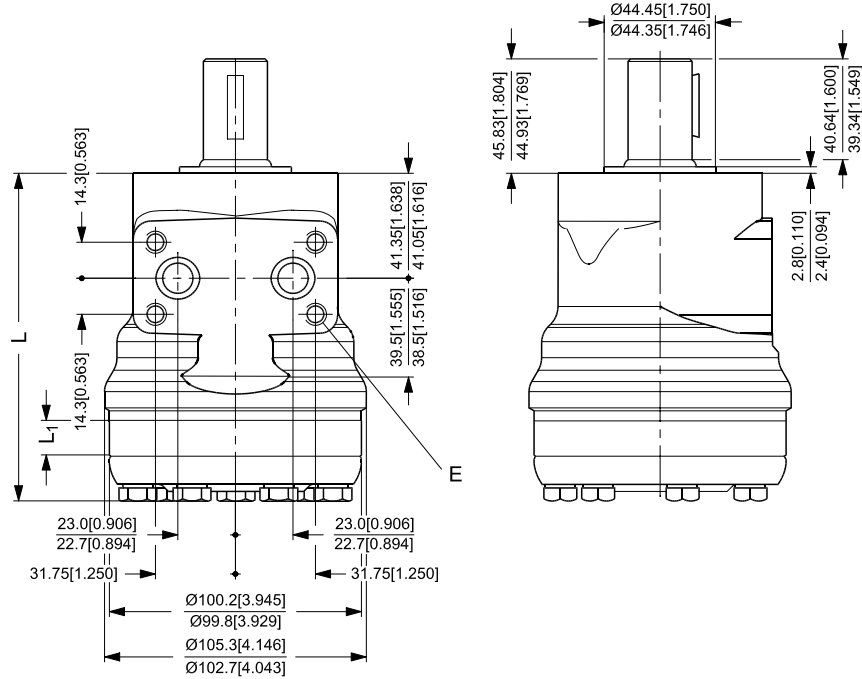

D: 2 × Ø17.48 mm [0.69 in]
 E: 3/8 - 16 UNC;
 15 mm [0.59 in] deep
 (4 off)
 F: 4 × 5/16 - 18 UNC;
 13 mm [0.51 in] deep

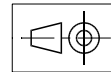
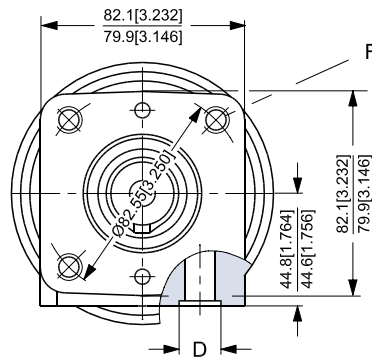

151-1894.10

INSTALLATION OF THE SAUER-DANFOSS ORBITAL MOTORS

About the design

- To ensure efficient operation all hydraulic components must be installed according to their individual instructions.
- The pump line must include a gage connection.
- To ensure designed contact and minimize the stress all mounting flanges must be flat.
- Hydraulic lines must be fitted correctly to prevent air entrapment.

About the assembly

- Follow the mounting instructions printed on the inside of the cardboard box.
- To prevent contamination, do not remove the plastic plugs from the connection ports until the fittings are ready to be assembled.
- Check that there is full face contact between the motor mounting flange and the mating part.
- Do not force the motor into place when tightening the mounting screws.
- Avoid unsuitable sealing material on fittings such as pack twine, Teflon and others. Use only bonded seals, O-rings, steel washers and the like.
- When tightening the fittings never use a torque higher than the max. tightening torque stated in the instructions.
- Make sure that the cleanliness of the oil used is better than 20/16 (ISO 4406). Always use a filter for oil refilling.

STARTING UP AND RUNNING IN THE HYDRAULIC SYSTEM

- Through a small-meshed filter fill up the tank with oil to the upper oil level mark .
- Start the drive engine, and if possible, let it work at its lowest speed. If the motor is provided with bleed screws, keep these open until the emerging oil is non-foaming.
- Check that all components are correctly connected (pump following the right direction of rotation etc.).
- In load-sensing systems, also make sure that the signal lines are free of entrapped air.
- Indications of air in the hydraulic system:
 - foam in the tank
 - jerky movements of motor and cylinder
 - noise
- If required, refill with oil.
- Connect the system to a separate tank that includes a filter (fineness max. 10 µm) with twice the capacity of the max. oil flow. Let the entire system run without load (no pressure) for about 30 minutes.
- Do not load the system until it is all bled and clean.
- Check the tightness of the system and make sure that its performance is satisfactory.
- Change the oil filter, and if required, refill with oil.

OPERATION

- Do not expose the motor to pressures, pressure drops and speeds above the max. values stated in the catalogue.
- Filter the oil to ensure that the contamination level 20/16 (ISO 4406) or better.

MAINTENANCE

- When working with hydraulic systems, the main criteria of operating safety and endurance is careful maintenance
- Always renew and replace oil, oil filters and air filters according to the instructions given by the respective manufacturers
- Regularly check the condition of the oil
- Frequently check system tightness and oil level

WEIGHT OF MOTORS

Code no.	Weight	
	kg	[lb]
151-2000	5.1	11.2
151-2001	5.1	11.2
151-2002	5.2	11.5
151-2003	5.4	11.9
151-2004	5.5	12.1
151-2005	5.7	12.6
151-2006	5.9	13.0
151-2007	6.1	13.4
151-2008	6.4	14.1
151-2009	6.9	15.2
151-2010	5.1	11.2
151-2011	5.1	11.2
151-2012	5.2	11.5
151-2013	5.4	11.9
151-2014	5.5	12.1
151-2015	5.7	12.6
151-2016	5.9	13.0
151-2017	6.1	13.4
151-2018	6.4	14.1
151-2019	6.9	15.2
151-2040	4.8	10.6
151-2041	4.8	10.6
151-2042	4.9	10.8
151-2043	5.1	11.2
151-2044	5.2	11.5
151-2045	5.4	11.9
151-2046	5.6	12.3
151-2047	5.8	12.8
151-2048	6.1	13.4
151-2049	6.6	14.6
151-2050	4.8	10.6
151-2051	4.8	10.6
151-2052	4.9	10.8
151-2053	5.1	11.2
151-2054	5.2	11.5
151-2055	5.4	11.9
151-2056	5.6	12.3
151-2057	5.8	12.8
151-2058	6.1	13.4
151-2059	6.6	14.6
151-2080	5.1	11.2
151-2081	5.1	11.2
151-2082	5.2	11.5
151-2083	5.4	11.9
151-2084	5.5	12.1
151-2085	5.7	12.6
151-2086	5.9	13.0
151-2087	6.1	13.4
151-2088	6.4	14.1

Code no.	Weight	
	kg	[lb]
151-2089	6.9	15.2
151-2090	5.1	11.2
151-2091	5.1	11.2
151-2092	5.2	11.5
151-2093	5.4	11.9
151-2094	5.5	12.1
151-2095	5.7	12.6
151-2096	5.9	13.0
151-2097	6.1	13.4
151-2098	6.4	14.1
151-2099	6.9	15.2
151-2120	4.8	10.6
151-2121	4.8	10.6
151-2122	4.9	10.8
151-2123	5.1	11.2
151-2124	5.2	11.5
151-2125	5.4	11.9
151-2126	5.6	12.3
151-2127	5.8	12.8
151-2128	6.1	13.4
151-2129	6.6	14.6
151-2130	4.8	10.6
151-2131	4.8	10.6
151-2132	4.9	10.8
151-2133	5.1	11.2
151-2134	5.2	11.5
151-2135	5.4	11.9
151-2136	5.6	12.3
151-2137	5.8	12.8
151-2138	6.1	13.4
151-2139	6.6	14.6
151-2160	5.1	11.2
151-2161	5.1	11.2
151-2162	5.2	11.5
151-2163	5.4	11.9
151-2164	5.5	12.1
151-2165	5.7	12.6
151-2166	5.9	13.0
151-2167	6.1	13.4
151-2168	6.4	14.1
151-2169	6.9	15.2
151-2170	5.1	11.2
151-2171	5.1	11.2
151-2172	5.2	11.5
151-2173	5.4	11.9
151-2174	5.5	12.1
151-2175	5.7	12.6
151-2176	5.9	13.0
151-2177	6.1	13.4

Code no.	Weight	
	kg	[lb]
151-2178	6.4	14.1
151-2179	6.9	15.2
151-2200	4.8	10.6
151-2201	4.8	10.6
151-2202	4.9	10.8
151-2203	5.1	11.2
151-2204	5.2	11.5
151-2205	5.4	11.9
151-2206	5.6	12.3
151-2207	5.8	12.8
151-2208	6.1	13.4
151-2209	6.6	14.6
151-2210	4.8	10.6
151-2211	4.8	10.6
151-2212	4.9	10.8
151-2213	5.1	11.2
151-2214	5.2	11.5
151-2215	5.4	11.9
151-2216	5.6	12.3
151-2217	5.8	12.8
151-2218	6.1	13.4
151-2219	6.6	14.6
151-2301	5.9	13.0
151-2302	6.1	13.4
151-2303	6.1	13.4
151-2304	6.2	13.7
151-2305	6.4	14.1
151-2306	6.7	14.8
151-2307	7.2	15.9
151-2308	7.7	17.0
151-2309	8.2	18.1
151-2311	5.9	13.0
151-2312	6.1	13.4
151-2313	6.1	13.4
151-2314	6.2	13.7
151-2315	6.4	14.1
151-2316	6.7	14.8
151-2317	7.2	11.0
151-2318	7.7	11.2
151-2319	8.2	11.7
151-2341	5.6	12.3
151-2342	5.8	12.8
151-2343	5.8	12.8
151-2344	5.9	13.0
151-2345	6.1	13.4
151-2346	6.4	14.1
151-2347	6.9	15.2
151-2348	7.4	16.3
151-2349	7.9	17.4

WEIGHT OF MOTORS

Code no.	Weight	
	kg	[lb]
151-2351	5.6	12.3
151-2352	5.8	12.8
151-2353	5.8	12.8
151-2354	5.9	13.0
151-2355	6.1	13.4
151-2356	6.4	14.1
151-2357	6.9	15.2
151-2358	7.4	16.3
151-2359	7.9	17.4
151-2381	5.9	13.0
151-2382	6.1	13.4
151-2383	6.1	13.4
151-2384	6.2	13.7
151-2385	6.4	14.1
151-2386	6.7	14.8
151-2387	7.2	15.9
151-2388	7.7	17.0
151-2389	8.2	18.1
151-2391	5.9	13.2
151-2392	6.1	13.7
151-2393	6.1	14.1
151-2394	6.2	14.6
151-2395	6.4	15.2
151-2396	6.7	16.3
151-2397	7.2	11.0
151-2398	7.7	11.2
151-2399	8.2	11.7
151-2421	5.6	12.3
151-2422	5.8	12.8
151-2423	5.8	12.8
151-2424	5.9	13.0
151-2425	6.1	13.4
151-2426	6.4	14.1
151-2427	6.9	15.2
151-2428	7.4	16.3
151-2429	7.9	17.4
151-2431	5.6	12.3
151-2432	5.8	12.8
151-2433	5.8	12.8
151-2434	5.9	13.0
151-2435	6.1	13.4
151-2436	6.4	14.1
151-2437	6.9	15.2
151-2438	7.4	16.3
151-2439	7.9	17.4
151-2461	5.9	13.0
151-2462	6.1	13.4
151-2463	6.1	13.4
151-2464	6.2	13.7

Code no.	Weight	
	kg	[lb]
151-2465	6.4	14.1
151-2466	6.7	14.8
151-2467	7.2	15.9
151-2468	7.7	17.0
151-2469	8.2	18.1
151-2471	5.9	12.3
151-2472	6.1	12.8
151-2473	6.1	13.2
151-2474	6.2	13.9
151-2475	6.4	15.0
151-2476	6.7	12.0
151-2477	7.2	12.0
151-2478	7.7	12.3
151-2479	8.2	18.1
151-2501	5.6	12.3
151-2502	5.8	12.8
151-2503	5.8	12.8
151-2504	5.9	13.0
151-2505	6.1	13.4
151-2506	6.4	14.1
151-2507	6.9	15.2
151-2508	7.4	16.3
151-2509	7.9	17.4
151-2511	5.6	12.3
151-2512	5.8	12.8
151-2513	5.8	12.8
151-2514	5.9	13.0
151-2515	6.1	13.4
151-2516	6.4	14.1
151-2517	6.9	15.2
151-2518	7.4	16.3
151-2519	7.9	17.4
151-3400	5.1	11.2
151-3401	5.1	11.2
151-3402	5.2	11.5
151-3403	5.4	11.9
151-3404	5.5	12.1
151-3405	5.7	12.6
151-3406	5.9	13.0
151-3407	6.1	13.4
151-3408	6.4	14.1
151-3409	6.9	15.2
151-3410	5.1	11.2
151-3411	5.1	11.2
151-3412	5.2	11.5
151-3413	5.4	11.9
151-3414	5.5	12.1
151-3415	5.7	12.6
151-3416	5.9	13.0

Code no.	Weight	
	kg	[lb]
151-3417	6.1	13.4
151-3418	6.4	14.1
151-3419	6.9	15.2
151-3440	4.8	10.6
151-3441	4.8	10.6
151-3442	4.9	10.8
151-3443	5.1	11.2
151-3444	5.2	11.5
151-3445	5.4	11.9
151-3446	5.6	12.3
151-3447	5.8	12.8
151-3448	6.1	13.4
151-3449	6.6	14.6
151-3450	4.8	10.6
151-3451	4.8	10.6
151-3452	4.9	10.8
151-3453	5.1	11.2
151-3454	5.2	11.5
151-3455	5.4	11.9
151-3456	5.6	12.3
151-3457	5.8	12.8
151-3458	6.1	13.4
151-3459	6.6	14.6
151-3480	5.1	11.2
151-3481	5.1	11.2
151-3482	5.2	11.5
151-3483	5.4	11.9
151-3484	5.5	12.1
151-3485	5.7	12.6
151-3486	5.9	13.0
151-3487	6.1	13.4
151-3488	6.4	14.1
151-3489	6.9	15.2
151-3520	4.8	10.6
151-3521	4.8	10.6
151-3522	4.9	10.8
151-3523	5.1	11.2
151-3524	5.2	11.5
151-3525	5.4	11.9
151-3526	5.6	12.3
151-3527	5.8	12.8
151-3528	6.1	13.4
151-3529	6.6	14.6
151-3570	5.1	11.2
151-3571	5.1	11.2
151-3572	5.2	11.5
151-3573	5.4	11.9
151-3574	5.5	12.1
151-3575	5.7	12.6

WEIGHT OF MOTORS

Code no.	Weight	
	kg	[lb]
151-3576	5.9	13.0
151-3577	6.1	13.4
151-3578	6.4	14.1
151-3579	6.9	15.2
151-3701	5.9	13.0
151-3702	6.1	13.4
151-3703	6.1	13.4
151-3704	6.2	13.7
151-3705	6.4	14.1
151-3706	6.7	14.8
151-3707	7.2	15.9
151-3708	7.7	17.0
151-3709	8.2	18.1
151-3711	5.9	11.9
151-3712	6.1	12.3
151-3713	6.1	12.8

Code no.	Weight	
	kg	[lb]
151-3714	6.2	13.2
151-3715	6.4	13.9
151-3716	6.7	15.0
151-3717	7.2	12.3
151-3718	7.7	12.6
151-3719	8.2	13.0
151-3741	5.6	12.3
151-3742	5.8	12.8
151-3743	5.8	12.8
151-3744	5.9	13.0
151-3745	6.1	13.4
151-3746	6.4	14.1
151-3747	6.9	15.2
151-3748	7.4	16.3
151-3749	7.9	17.4
151-3781	5.9	13.0

Code no.	Weight	
	kg	[lb]
151-3782	6.1	13.4
151-3783	6.1	13.4
151-3784	6.2	13.7
151-3785	6.4	14.1
151-3786	6.7	14.8
151-3787	7.2	15.9
151-3788	7.7	17.0
151-3789	8.2	18.1
151-3821	5.6	12.3
151-3822	5.8	12.8
151-3823	5.8	12.8
151-3824	5.9	13.0
151-3825	6.1	13.4
151-3826	6.4	14.1
151-3827	6.9	15.2
151-3828	7.4	16.3
151-3829	7.9	17.4



DH and DS
Orbital Motors
Notes

NOTES



DH and DS
Orbital Motors
Notes

NOTES



DH and DS
Orbital Motors
Notes

NOTES

OUR PRODUCTS

Hydrostatic transmissions
Hydraulic power steering
Electric power steering
Closed and open circuit axial piston pumps and motors
Gear pumps and motors
Bent axis motors
Radial piston motors
Orbital motors
Transit mixer drives
Planetary compact gears
Proportional valves
Directional spool valves
Cartridge valves
Hydraulic integrated circuits
Hydrostatic transaxles
Integrated systems
Fan drive systems
Electrohydraulic controls
Digital electronics and software
Battery powered inverter
Sensors

Sauer-Danfoss Hydraulic Power Systems – Market Leaders Worldwide

Sauer-Danfoss is a comprehensive supplier providing complete systems to the global mobile market.

Sauer-Danfoss serves markets such as agriculture, construction, road building, material handling, municipal, forestry, turf care, and many others.

We offer our customers optimum solutions for their needs and develop new products and systems in close cooperation and partnership with them.

Sauer-Danfoss specializes in integrating a full range of system components to provide vehicle designers with the most advanced total system design.

Sauer-Danfoss provides comprehensive worldwide service for its products through an extensive network of Authorized Service Centers strategically located in all parts of the world.

Sauer-Danfoss (US) Company
2800 East 13th Street
Ames, IA 50010, USA
Phone: +1 515 239-6000, Fax: +1 515 239-6618

Sauer-Danfoss (Neumünster) GmbH & Co. OHG
Postfach 2460, D-24531 Neumünster
Krokamp 35, D-24539 Neumünster, Germany
Phone: +49 4321 871-0, Fax: +49 4321 871-122

Sauer-Danfoss (Nordborg) A/S
DK-6430 Nordborg, Denmark
Phone: +45 7488 4444, Fax: +45 7488 4400

www.sauer-danfoss.com